

**TITLE 11 CONSUMER PROTECTION DIVISION OF  
THE OFFICE OF THE ATTORNEY GENERAL**

**Proposed Rule**  
LSA Document #02-110

DIGEST

Amends 11 IAC 2-6-1 concerning the fees charged for the telephone privacy list. Amends 11 IAC 2-6-5 to clarify the information contained in the telephone privacy list. Adds 11 IAC 2-6-6 to prohibit unauthorized duplication or dissemination of the telephone privacy list. Effective 30 days after filing with the secretary of state.

**11 IAC 2-6-1**  
**11 IAC 2-6-5**  
**11 IAC 2-6-6**

SECTION 1. 11 IAC 2-6-1, AS ADDED AT 25 IR 1857, SECTION 1, IS AMENDED TO READ AS FOLLOWS:

**11 IAC 2-6-1 Fee for obtaining telephone privacy list**

**Authority:** IC 4-6-9-8; IC 24-4.7-3-7  
**Affected:** IC 24-4.7-3-1

Sec. 1. (a) The fee for obtaining the telephone privacy list on **CD-ROM or via download from the telephone privacy Web site is three hundred seven hundred fifty dollars (\$300). (\$750).** The person paying this fee is entitled to four (4) **consecutive** quarterly publications of the telephone privacy list.

(b) **The fee for obtaining the telephone privacy list in printed hard copy format is the fee established under subsection (a), plus fifteen cents (\$0.15) per page.** (*Consumer Protection Division of the Office of the Attorney General; 11 IAC 2-6-1; filed Jan 18, 2002, 5:00 p.m.: 25 IR 1857*)

SECTION 2. 11 IAC 2-6-5, AS ADDED AT 25 IR 1858, SECTION 1, IS AMENDED TO READ AS FOLLOWS:

**11 IAC 2-6-5 Information contained in published telephone privacy list**

**Authority:** IC 4-6-9-8; IC 24-4.7-3-7  
**Affected:** IC 24-4.7-3-1; IC 24-4.7-3-2; IC 24-4.7-4

Sec. 5. The telephone privacy list published by the division, ~~shall~~, regardless of its form, **shall not** contain ~~only~~ **names, addresses, or other identifying information beyond** the residential telephone numbers that telephone solicitors are prohibited from calling under IC 24-4.7-4. (*Consumer Protection Division of the Office of the Attorney General; 11 IAC 2-6-5; filed Jan 18, 2002, 5:00 p.m.: 25 IR 1858*)

SECTION 3. 11 IAC 2-6, AS ADDED AT 25 IR 1857, SECTION 1, IS AMENDED BY ADDING A NEW SECTION TO READ AS FOLLOWS:

**11 IAC 2-6-6 Unauthorized duplication or dissemination of telephone privacy list prohibited**

**Authority:** IC 4-6-9-8; IC 24-4.7-3-7  
**Affected:** IC 24-4.7-3-1; IC 24-4.7-3-2

**Sec. 6. A person obtaining a copy of the telephone privacy list shall not disseminate, duplicate, distribute, transmit, or photocopy the list to third parties without the prior written consent of the division.** (*Consumer Protection Division of the Office of the Attorney General; 11 IAC 2-6-6*)

**Notice of Public Hearing**

*Under IC 4-22-2-24, notice is hereby given that on July 30, 2002 at 10:00 a.m., at the Office of the Attorney General, Indiana Government Center-South, 402 West Washington Street, Fifth Floor, West Conference Room, Indianapolis, Indiana the Consumer Protection Division of the Office of the Attorney General will hold a public hearing on proposed amendments to rules relating to fees charged for, information contained in, and unauthorized duplication of the telephone privacy list. Copies of these rules are now on file at the Indiana Government Center-South, 402 West Washington Street, Fifth Floor and Legislative Services Agency, One North Capitol, Suite 325, Indianapolis, Indiana and are open for public inspection.*

Brent Embrey  
Director of Telephone Privacy  
Consumer Protection Division of the Office of the  
Attorney General

---

---

**TITLE 31 STATE PERSONNEL DEPARTMENT**

**Proposed Rule**  
LSA Document #02-10

DIGEST

Amends 31 IAC 1-9-3, 31 IAC 1-9-4, 31 IAC 1-9-4.5, 31 IAC 2-11-3, 31 IAC 2-11-4, and 31 IAC 2-11-4.5 to reference the new leave conversion into deferred compensation plan. Adds 31 IAC 5 to provide that a portion of accrued but unused vacation and sick leave will be converted into the deferred compensation plan. Repeals 31 IAC 1-12.1, 31 IAC 2-17.1, and 31 IAC 4. Effective December 31, 2002.

<b>31 IAC 1-9-3</b>	<b>31 IAC 2-11-4</b>
<b>31 IAC 1-9-4</b>	<b>31 IAC 2-11-4.5</b>
<b>31 IAC 1-9-4.5</b>	<b>31 IAC 2-17.1</b>
<b>31 IAC 1-12.1</b>	<b>31 IAC 4</b>
<b>31 IAC 2-11-3</b>	<b>31 IAC 5</b>

SECTION 1. 31 IAC 1-9-3 IS AMENDED TO READ AS FOLLOWS:

## Proposed Rules

### 31 IAC 1-9-3 Vacation leave

Authority: IC 4-15-1.8-6; IC 4-15-1.8-7

Affected: IC 4-15-1.8-7

Sec. 3. (a) Vacation leave with pay shall be earned by all full-time employees in the non-merit service at the rate of seven and one-half (7.5) hours for each full month of employment. Employees working at least half time, but no less than a full-time basis, shall earn vacation at the rate of three and three-fourths (3.75) hours a month. Vacation will not be credited to hourly, per diem, temporary, intermittent, contractual, or employees working less than half time.

(b) Eligibility for additional vacation days shall be as follows:

(1) Employees who have completed five (5) years or more of full-time employment, or ten (10) years or more of half-time employment, shall accrue twenty-two and one-half (22.5) additional hours of vacation leave with pay annually on their accrual date.

(2) Employees who have completed ten (10) years or more of full-time employment, or twenty (20) years or more of half-time employment, shall accrue thirty-seven and one-half (37.5) additional hours of vacation leave with pay (twenty-two and one-half (22.5) plus thirty-seven and one-half (37.5) for a total of sixty (60) additional hours) annually on their accrual date.

(3) Employees who have completed twenty (20) years or more of full-time employment, or forty (40) years or more of half-time employment, shall accrue thirty-seven and one-half (37.5) additional hours of vacation leave with pay (twenty-two and one-half (22.5) plus thirty-seven and one-half (37.5) plus thirty-seven and one-half (37.5) for a total of ninety-seven and one-half (97.5) additional hours) annually on their accrual date.

(4) Time spent in out-of-pay status, except for military service, shall be deducted from total service time in computing eligibility for additional vacation leave.

(5) Noncontinuous service prior to June 30, 1982, shall not be considered in determining eligibility for additional vacation leave.

(c) No vacation shall accrue to full-time employees during the first six (6) months of employment, or to part-time employees during the first twelve (12) months of employment, but, upon completion thereof, regular vacation leave shall be allowed for time served during such periods.

(d) Appointing authorities shall determine the time and amount of vacation which shall be taken at any one (1) time. Employees shall be limited to four (4) calendar weeks of vacation at any one (1) time unless a longer period is recommended by the appointing authority and approved by the director. Employees granted special sick leave with pay shall be entitled to all earned vacation and earned overtime.

(e) For the good of the service in arranging vacation sched-

ules, the director may approve the request of an appointing authority for full-time employees to anticipate and take vacation leave not to exceed twenty-two and one-half (22.5) hours.

(f) Compensation for unused vacation, earned overtime, and holidays on separation shall be as follows:

(1) Except as otherwise provided in ~~31 IAC 1-12.1 or 31 IAC 4~~ **31 IAC 5**, upon separation from the service, in good standing, an employee shall be paid for unused vacation for a maximum of two hundred twenty-five (225) hours, plus overtime and holiday leave to the extent accumulated.

(2) Compensation for unused vacation in excess of six (6) calendar weeks is only permitted ~~in cases involving payment of premiums for early retiree health insurance as provided in 31 IAC 1-12.1 or under the retiree flexible spending program described in 31 IAC 4~~ **31 IAC 5**.

(3) Payment for unused vacation leave, not to exceed two hundred twenty-five (225) hours, and all earned overtime and holiday leave shall be paid to beneficiaries of deceased employees.

(4) If the employee has anticipated vacation leave in accordance with subsection (e) of this section, and separated from the service before actually earning such leave, payment for leave used but unearned shall be deducted from the final payment of salary.

(5) Full-time employees who resign before they have completed six (6) months of non-merit employment, or part-time employees who resign before completing one (1) year of non-merit employment, will not be paid for any vacation leave.

(g) Charging of leave shall be as follows:

(1) Vacation leave shall be charged in fifteen (15) minute increments.

(2) Vacation shall not be charged on a legal holiday.

(h) An employee who resigns in good standing **or retires** after June 30, 1982, and is subsequently rehired shall have reinstated, six (6) months after rehire, any vacation leave that was accrued but was unused and uncompensated at the time of their resignation. However, vacation leave that was compensated under **former rules** 31 IAC 1-12.1 or 31 IAC 4 shall not be reinstated.

(i) In recognition of the fact that conservation officers and excise police have a standard work day of eight and one-half (8.5) hours instead of seven and one-half (7.5) hours, the references to the numbers of hours in this section shall be converted for conservation officers and excise police as follows:

Hours Stated in this Section	Hours Converted for Conservation and Excise
3.75	4.25
7.5	8.5
22.5	25.5
37.5	42.5

60.0	68.0
97.5	110.5
225.0	255.0

If an employee transfers into or out of the conservation officer or excise police job families, the employee's leave balances will be adjusted proportionately to reflect the change in the number of hours of the standard work day. (*State Personnel Department; Non-Merit Agency Personnel Rule 9, Sec 3; filed Feb 15, 1978, 3:25 p.m.: Rules and Regs. 1979, p. 34; filed Jan 26, 1979, 2:50 p.m.: 2 IR 296; filed Apr 28, 1982, 12:55 p.m.: 5 IR 1169; filed Nov 1, 1983, 4:00 p.m.: 7 IR 10, eff Jan 1, 1984; filed Dec 1, 1995, 3:00 p.m.: 19 IR 610, eff Jan 1, 1996; filed Dec 1, 1997, 4:30 p.m.: 21 IR 1251, eff Jan 1, 1998; filed May 10, 2000, 3:24 p.m.: 23 IR 2402, eff Jul 1, 2000; readopted filed May 4, 2001, 4:29 p.m.: 24 IR 2895*) *NOTE: Transferred from the Indiana department of administration (25 IAC 3) to the state personnel department (31 IAC 1) by Acts 1981, P.L.30, SECTION 3 (IC 4-15-1.8-8). Effective July 1, 1981.*

SECTION 2. 31 IAC 1-9-4 IS AMENDED TO READ AS FOLLOWS:

**31 IAC 1-9-4 Sick leave; definition; accrual**

**Authority:** IC 4-15-1.8-6; IC 4-15-1.8-7  
**Affected:** IC 4-15-1.8-7

Sec. 4. (a) Sick leave is defined as absence from duty of any employee because of personal illness, injury, or legal quarantine. Sick leave may also be used for an illness or injury in the employee's immediate family that necessitates the employee's absence from work. For this purpose, "immediate family" means spouse, child, or parent who resides with, and is dependent upon, the employee for care and support. The director or appointing authority may at any time require of an employee a medical certificate from the attending physician or a designated physician, documenting the nature and extent of the disability or fitness to return to duty. The cost of such certification from a designated physician shall be the responsibility of the appointing authority. Sick leave may be granted if accrued and shall be charged in the same manner as vacation in accordance with section 3(g) of this rule.

(b) Sick leave with pay shall accrue to full-time employees in the nonmerit service at the rate of seven and one-half (7.5) hours for every two (2) full months of employment; plus seven and one-half (7.5) additional hours for every four (4) months of full-time employment. Employees working on a part-time basis shall earn sick leave at the rate of three and three-fourths (3.75) hours for every two (2) months of employment; plus, three and three-fourths (3.75) additional hours for every four (4) months of employment. Sick leave will not accrue to hourly, per diem, temporary, intermittent, or contractual employees or employees working less than half time.

(c) On separation, compensation for unused sick leave is only permitted under the retiree flexible spending program described in ~~31 IAC 4~~ **31 IAC 5**.

(d) An employee who resigns in good standing **or retires** after June 30, 1982, and is subsequently rehired shall have reinstated any sick leave which was unused and uncompensated at the time of their resignation.

(e) In recognition of the fact that conservation officers and excise police have a standard work day of eight and one-half (8.5) hours instead of seven and one-half (7.5) hours, the references to the numbers of hours in this section shall be converted for conservation officers and excise police as follows:

Hours Stated in this Section	Hours Converted for Conservation and Excise
3.75	4.25
7.5	8.5

If an employee transfers into or out of the conservation officer or excise police job families, the employee's leave balances will be adjusted proportionately to reflect the change in the number of hours of the standard work day. (*State Personnel Department; Non-Merit Agency Personnel Rule 9, Sec 4; filed Feb 15, 1978, 3:25 p.m.: Rules and Regs. 1979, p. 35; filed Aug 23, 1978, 3:35 p.m.: 1 IR 634; filed Jan 26, 1979, 2:50 p.m.: 2 IR 296; filed Apr 28, 1982, 12:55 p.m.: 5 IR 1170; filed Aug 17, 1982, 3:41 p.m.: 5 IR 2104; filed Nov 1, 1983, 4:00 p.m.: 7 IR 11, eff Jan 1, 1984; filed Sep 8, 1992, 5:00 p.m.: 16 IR 6; filed Dec 1, 1997, 4:30 p.m.: 21 IR 1252, eff Jan 1, 1998; filed May 10, 2000, 3:24 p.m.: 23 IR 2403, eff Jul 1, 2000; readopted filed May 4, 2001, 4:29 p.m.: 24 IR 2895*) *NOTE: Transferred from the Indiana department of administration (25 IAC 3) to the state personnel department (31 IAC 1) by Acts 1981, P.L.30, SECTION 3 (IC 4-15-1.8-8). Effective July 1, 1981.*

SECTION 3. 31 IAC 1-9-4.5 IS AMENDED TO READ AS FOLLOWS:

**31 IAC 1-9-4.5 Personal leave**

**Authority:** IC 4-15-1.8-6; IC 4-15-1.8-7  
**Affected:** IC 4-15-1.8-7

Sec. 4.5. (a) Personal leave is defined as absence from duty with pay for personal reasons.

(b) Personal leave shall accrue to full-time employees at the rate of seven and one-half (7.5) hours for every four (4) months of full-time employment and to part-time employees working at least half time at the rate of three and three-fourths (3.75) hours for every four (4) months of service. Personal leave shall not be granted to hourly, per diem, temporary, intermittent, contractual, or employees working less than half time.

(c) No employee may accrue a personal leave balance in excess of twenty-two and one-half (22.5) hours. If an employee is otherwise eligible to accrue personal leave, but the accrual thereof would increase his or her account balance beyond the twenty-two and one-half (22.5) hour limit, the personal leave shall be credited to the employee's accrued sick leave balance.

## Proposed Rules

(d) The appointing authority may establish procedures for employees to follow in securing authorization for absence on personal leave.

(e) On separation, compensation for unused personal leave is only permitted under ~~the retiree flexible spending program described in 31 IAC 4-31 IAC 5-5-1.~~

(f) An employee who resigns in good standing **or retires** after June 30, 1982, and is subsequently rehired shall have reinstated, six (6) months after rehire, any personal leave that was accrued but unused and uncompensated at the time of their resignation.

(g) In recognition of the fact that conservation officers and excise police have a standard work day of eight and one-half (8.5) hours instead of seven and one-half (7.5) hours, the references to the numbers of hours in this section shall be converted for conservation officers and excise police as follows:

Hours Stated in this Section	Hours Converted for Conservation and Excise
3.75	4.25
7.5	8.5
22.5	25.5

If an employee transfers into or out of the conservation officer or excise police job families, the employee's leave balances will be adjusted proportionately to reflect the change in the number of hours of the standard work day. (*State Personnel Department; 31 IAC 1-9-4.5; filed Apr 28, 1982, 12:55 p.m.: 5 IR 1170; filed Nov 1, 1983, 4:00 p.m.: 7 IR 11, eff Jan 1, 1984; filed Dec 1, 1997, 4:30 p.m.: 21 IR 1253, eff Jan 1, 1998; filed May 10, 2000, 3:24 p.m.: 23 IR 2404, eff Jul 1, 2000; readopted filed May 4, 2001, 4:29 p.m.: 24 IR 2895*) *NOTE: Transferred from the Indiana department of administration (25 IAC 3) to the state personnel department (31 IAC 1) by Acts 1981, P.L.30, SECTION 3 (IC 4-15-1.8-8). Effective July 1, 1981.*

SECTION 4. 31 IAC 2-11-3 IS AMENDED TO READ AS FOLLOWS:

### 31 IAC 2-11-3 Vacation leave

**Authority:** IC 4-15-2-6

**Affected:** IC 4-15-2-29; IC 4-15-2-30

Sec. 3. (a) Vacation leave with pay shall be earned by all full-time employees in the classified service at the rate of seven and one-half (7.5) hours for each full month of employment. Employees working on a part-time basis shall earn vacation at the rate of three and three-fourths (3.75) hours a month. Vacation will not be credited to hourly, per diem, temporary, intermittent, contractual, or employees working less than half time.

(b) Eligibility for additional vacation shall be as follows:

(1) Employees who have completed five (5) years or more of

full-time employment, or ten (10) years or more of half-time employment, shall accrue twenty-two and one-half (22.5) additional hours of vacation leave with pay annually on their accrual date.

(2) Employees who have completed ten (10) years or more of full-time employment, or twenty (20) years or more of half-time employment, shall accrue thirty-seven and one-half (37.5) additional hours of vacation leave with pay (twenty-two and one-half (22.5) plus thirty-seven and one-half (37.5) for a total of sixty (60) additional hours) annually on their accrual date.

(3) Employees who have completed twenty (20) years or more of full-time employment, or forty (40) years or more of half-time employment, shall accrue thirty-seven and one-half (37.5) additional hours of vacation leave with pay (twenty-two and one-half (22.5) plus thirty-seven and one-half (37.5) plus thirty-seven and one-half (37.5) for a total of ninety-seven and one-half (97.5) additional hours) annually on their accrual date.

(4) Time spent in out-of-pay status, except for military service, shall be deducted from total service time in computing eligibility for additional vacation leave.

(5) Noncontinuous service prior to June 30, 1982, shall not be considered in determining eligibility for additional vacation leave.

(c) No vacation shall accrue to full-time employees during the first six (6) months of employment, or to part-time employees during the first twelve (12) months of employment, but, upon completion thereof, regular vacation leave shall be allowed for time served during such periods.

(d) Appointing authorities shall determine the time and amount of vacation which shall be taken at any one (1) time. Employees shall be limited to four (4) calendar weeks of vacation at any one (1) time unless a longer period is recommended by the appointing authority and approved by the director. Employees granted special sick leave with pay shall be entitled to all earned vacation and earned overtime.

(e) For the good of service in arranging vacation schedules, the director may approve the request of an appointing authority for full-time employees to anticipate and take vacation leave not to exceed twenty-two and one-half (22.5) hours. Employees in professional teaching classes in institutional schools may anticipate vacation and overtime to the extent necessitated by the school schedule, except that no deficit leave balance shall extend beyond the school year.

(f) Compensation for unused vacation, earned overtime, and holidays on separation shall be as follows:

(1) Except as otherwise provided in ~~31 IAC 2-17-1 or 31 IAC 4-31 IAC 5~~, upon separation from the service, in good standing, an employee shall be paid for unused vacation for a maximum of two hundred twenty-five (225) hours, plus

earned overtime and holiday leave to the extent accumulated.

(2) Compensation for unused vacation in excess of six (6) calendar weeks is only permitted ~~in cases involving payment of premiums for early retiree health insurance as provided in 31 IAC 2-17.1 or the retiree flexible spending program described in 31 IAC 4-~~ **under 31 IAC 5.**

(3) Payment for unused vacation leave, not to exceed two hundred twenty-five (225) hours, and all earned overtime and holiday leave shall be paid to beneficiaries of deceased employees.

(4) If the employee has anticipated vacation or holiday leave, and separated from the service before actually earning such leave, payment for leave used but unearned shall be deducted from the final payment of salary.

(5) Full-time employees who resign before they have completed six (6) months of merit employment, or part-time employees who resign before completing one (1) year of merit employment, will not be paid for any vacation leave.

(g) Charging of leave shall be as follows:

(1) Vacation leave shall be charged in fifteen (15) minute increments.

(2) Vacation shall not be charged on a legal holiday.

(h) An employee who resigns in good standing **or retires** after June 30, 1982, and is subsequently rehired shall have reinstated, six (6) months after rehire, any vacation leave that was accrued but was unused and uncompensated at the time of their resignation. However, vacation leave that was compensated under **former rules** 31 IAC 2-17.1 or 31 IAC 4 shall not be reinstated. (*State Personnel Department; Rule 11, Sec 11-3; filed Aug 17, 1967, 8:40 a.m.: Rules and Regs. 1968, p. 125; filed Apr 19, 1972, 9:10 a.m.: Rules and Regs. 1973, p. 516; filed Apr 28, 1982, 12:50 p.m.: 5 IR 1165, eff Jun 30, 1982; filed Nov 1, 1983, 4:00 p.m.: 7 IR 18, eff Jan 1, 1984; filed Dec 1, 1995, 3:00 p.m.: 19 IR 612, eff Jan 1, 1996; filed Dec 1, 1997, 4:30 p.m.: 21 IR 1254, eff Jan 1, 1998; filed May 10, 2000, 3:24 p.m.: 23 IR 2404, eff Jul 1, 2000; readopted filed May 4, 2001, 4:29 p.m.: 24 IR 2895*) **NOTE: Transferred from the state personnel board (30 IAC 1) to the state personnel department (31 IAC 2) by Acts 1982, P.L.23, SECTION 41. Effective July 1, 1982.**

SECTION 5. 31 IAC 2-11-4 IS AMENDED TO READ AS FOLLOWS:

**31 IAC 2-11-4 Sick leave**

**Authority:** IC 4-15-2-6

**Affected:** IC 4-15-2-29; IC 4-15-2-30

Sec. 4. (a) Sick leave is defined as absence from duty of an employee because of personal illness, injury, or legal quarantine. Sick leave may also be used for an illness or injury in the employee's immediate family that necessitates the employee's absence from work. For this purpose, "immediate family" means spouse, child, or parent who resides with, and is depend-

ent upon, the employee for care and support. The director or appointing authority may at any time require of an employee a medical certificate from the attending physician or a designated physician, documenting the nature and extent of the disability or fitness to return to duty. The cost of such certification from a designated physician shall be the responsibility of the appointing authority. Sick leave may be granted if accrued and shall be charged in the same manner as vacation leave in accordance with section 3(g) of this rule.

(b) Sick leave with pay shall accrue to full-time employees in the classified service at the rate of seven and one-half (7.5) hours for every two (2) full months of employment; plus, seven and one-half (7.5) additional hours for every four (4) months of full-time employment. Employees working on a part-time basis shall earn sick leave at the rate of three and three-fourths (3.75) hours for every two (2) months of employment; plus, three and three-fourths (3.75) additional hours for every four (4) months of employment. Sick leave will not accrue to hourly, per diem, temporary, intermittent, or contractual employees or employees working less than half time.

(c) On separation, compensation for unused sick leave is only permitted under ~~the retiree flexible spending program described in 31 IAC 4-~~ **31 IAC 5.**

(d) An employee who resigns in good standing **or retires** after June 30, 1982, and is subsequently rehired shall have reinstated any accrued sick leave that was unused and uncompensated at the time of their resignation. (*State Personnel Department; Rule 11, Sec 11-4; filed Aug 17, 1967, 8:40 a.m.: Rules and Regs. 1968, p. 127; filed Apr 19, 1972, 9:10 a.m.: Rules and Regs. 1973, p. 517; filed Jan 10, 1979, 3:40 p.m.: 2 IR 136; filed Apr 28, 1982, 12:50 p.m.: 5 IR 1166; filed Aug 17, 1982, 3:45 p.m.: 5 IR 2093; filed Nov 1, 1983, 4:00 p.m.: 7 IR 19, eff Jan 1, 1984; filed Sep 8, 1992, 5:00 p.m.: 16 IR 6; filed Dec 1, 1997, 4:30 p.m.: 21 IR 1255, eff Jan 1, 1998; filed May 10, 2000, 3:24 p.m.: 23 IR 2405, eff Jul 1, 2000; readopted filed May 4, 2001, 4:29 p.m.: 24 IR 2895*) **NOTE: Transferred from the state personnel board (30 IAC 1) to the state personnel department (31 IAC 2) by Acts 1982, P.L.23, SECTION 41. Effective July 1, 1982.**

SECTION 6. 31 IAC 2-11-4.5 IS AMENDED TO READ AS FOLLOWS:

**31 IAC 2-11-4.5 Personal leave**

**Authority:** IC 4-15-2-6

**Affected:** IC 4-15-2-29; IC 4-15-2-30

Sec. 4.5. (a) Personal leave is defined as absence from duty with pay for personal reasons.

(b) Personal leave shall accrue to full-time employees at the rate of seven and one-half (7.5) hours for every four (4) months of full-time employment and to part-time employees working at

## Proposed Rules

least half time at the rate of three and three-fourths (3.75) hours for every four (4) months of service. Personal leave shall not be granted to hourly, per diem, temporary, intermittent, contractual, or employees working less than half time.

(c) No employee may accrue a personal leave balance in excess of twenty-two and one-half (22.5) hours. If an employee is otherwise eligible to accrue personal leave, but the accrual thereof would increase his or her account balance beyond the twenty-two and one-half (22.5) hour limit, the personal leave shall be credited to the employee's accrued sick leave balance.

(d) The appointing authority may establish procedures for employees to follow in securing authorization for absence on personal leave.

(e) On separation, compensation for unused personal leave is only permitted under the retiree flexible spending program described in 31 IAC 4-31 IAC 5-5-1.

(f) An employee who resigns in good standing or retires after June 30, 1982, and is subsequently rehired shall have reinstated, six (6) months after rehire, any personal leave that was accrued but unused and uncompensated at the time of their resignation. (*State Personnel Department; 31 IAC 2-11-4.5; filed Apr 28, 1982, 12:50 p.m.: 5 IR 1166, eff Jun 30, 1982; filed Nov 1, 1983, 4:00 p.m.: 7 IR 20, eff Jan 1, 1984; filed Dec 1, 1997, 4:30 p.m.: 21 IR 1256, eff Jan 1, 1998; filed May 10, 2000, 3:24 p.m.: 23 IR 2406, eff Jul 1, 2000; readopted filed May 4, 2001, 4:29 p.m.: 24 IR 2895*) NOTE: Transferred from the state personnel board (30 IAC 1) to the state personnel department (31 IAC 2) by Acts 1982, P.L.23, SECTION 41. Effective July 1, 1982.

SECTION 7. 31 IAC 5 IS ADDED TO READ AS FOLLOWS:

### ARTICLE 5. CONVERSION OF ACCRUED LEAVE INTO DEFERRED COMPENSATION

#### Rule 1. Definitions

##### 31 IAC 5-1-1 "State agency" defined

Authority: IC 4-15-1.8-6; IC 4-15-1.8-7; IC 5-10-1.1-7.5  
Affected: IC 5-10-1.1-1; IC 5-10-12-3; IC 20-12-0.5-1

Sec. 1. As used in this article, "state agency" means the following:

- (1) An authority, a board, a branch, a commission, a committee, a department, a division, or other instrumentality of state government.
- (2) A separate corporate body politic that adopts this plan.
- (3) State elected officials and their office staff.
- (4) The legislative services agency.
- (5) Legislative staff eligible to participate in the state employees' deferred compensation plan established by IC 5-10-1.1-1.

However, the term does not include a state educational institution (as defined in IC 20-12-0.5-1) or a political subdivision. (*State Personnel Department; 31 IAC 5-1-1*)

#### Rule 2. Applicability

##### 31 IAC 5-2-1 Applicability

Authority: IC 4-15-1.8-6; IC 4-15-1.8-7; IC 5-10-1.1-7.7  
Affected: IC 5-10-1.1-7.5; IC 5-10-12-3

Sec. 1. (a) This article applies to an employee of a state agency that participates in the Indiana deferred compensation matching plan.

(b) A state agency that does not offer the Indiana deferred compensation matching plan must amend the plan documents that establish its benefit plan to implement the provisions of IC 5-10-1.1-7.5.

(c) Employees on long term disability are not eligible to convert leave into the Indiana deferred compensation matching plan. (*State Personnel Department; 31 IAC 5-2-1*)

#### Rule 3. Conversion and Vesting

##### 31 IAC 5-3-1 Mandatory conversion

Authority: IC 4-15-1.8-6; IC 4-15-1.8-7; IC 5-10-1.1-7.5  
Affected: IC 5-10-1.1; IC 5-10-12-3

Sec. 1. On December 31 of each year, the state will reduce an employee's accrued leave balance and deposit into the employee's account in the Indiana deferred compensation matching plan, the amount determined in 31 IAC 5-4. (*State Personnel Department; 31 IAC 5-3-1*)

##### 31 IAC 5-3-2 Voluntary conversion

Authority: IC 4-15-1.8-6; IC 4-15-1.8-7; IC 5-10-1.1-7.5  
Affected: IC 5-10-1.1; IC 5-10-12-3

Sec. 2. An employee may elect to voluntarily convert, effective December 31 of each calendar year, an amount of leave equivalent to that subject to mandatory conversion under section 1 of this rule for deposit into the employee's account in the Indiana deferred compensation matching plan. (*State Personnel Department; 31 IAC 5-3-2*)

##### 31 IAC 5-3-3 Vesting

Authority: IC 4-15-1.8-6; IC 4-15-1.8-7; IC 5-10-1.1-7.5  
Affected: IC 5-10-1.1; IC 5-10-12-3

Sec. 3. Deposits in the Indiana deferred compensation matching plan are fully and immediately vested. (*State Personnel Department; 31 IAC 5-3-3*)

#### Rule 4. Leave Valuation and Conversion

##### 31 IAC 5-4-1 Leave valuation

Authority: IC 4-15-1.8-6; IC 4-15-1.8-7; IC 5-10-1.1-7.5  
Affected: IC 5-10-1.1; IC 5-10-12-3

**Sec. 1.** For purposes of conversion, the value of sick and vacation is determined as follows:

**STEP ONE:** Divide the employee's regular biweekly salary, as reflected on the state personnel department's staffing report as of the conversion date, by seventy-five (75).

**STEP TWO:** Multiply the quotient determined in STEP ONE by the number of hours to be converted.

**STEP THREE:** Multiply the product of STEP TWO by sixty percent (60%).

*(State Personnel Department; 31 IAC 5-4-1)*

**31 IAC 5-4-2 Amount converted**

Authority: IC 4-15-1.8-6; IC 4-15-1.8-7; IC 5-10-1.1-7.5

Affected: IC 5-10-1.1; IC 5-10-12-3

**Sec. 2. (a)** The following amount of leave must be converted annually under 31 IAC 5-3-1 and may be converted annually under 31 IAC 5-3-2:

<u>Leave Balance (in hours)</u>	<u>Hours Converted</u>
≥ 300 < 375 vacation	22.5
≥ 300 < 375 sick	22.5
≥ 375 < 525 vacation	45
≥ 375 < 525 sick	45
≥ 525 < 750 vacation	75
≥ 525 < 750 sick	75
≥ 750 vacation	120
≥ 750 sick	120

**(b)** Personal leave and special sick leave are not eligible for conversion. *(State Personnel Department; 31 IAC 5-4-2)*

**Rule 5. Election of Prior Benefit Formula**

**31 IAC 5-5-1 Election of prior benefit formula**

Authority: IC 4-15-1.8-6; IC 4-15-1.8-7; IC 5-10-12-1.1-7.5

Affected: IC 5-10-1.1; IC 5-10-12-3

**Sec. 1.** A person who retires between December 31, 2002, and January 1, 2008, and who would have received more money under the previous retiree flexible spending program (the former 31 IAC 4) will be paid the difference between the proceeds received under this rule and the amount they would have received under the retiree flexible spending program. *(State Personnel Department; 31 IAC 5-5-1)*

**Rule 6. Limitations**

**31 IAC 5-6-1 Limitations**

Authority: IC 4-15-1.8-6; IC 4-15-1.8-7; IC 5-10-1.1-7.5

Affected: IC 5-10-1.1; IC 5-10-12-3

**Sec. 1.** This rule does not create any additional rights to compensation for accrued but unused vacation or sick leave beyond those rights expressly granted in this article. Except as otherwise provided in this article, a state employee is not

entitled to compensation at separation for unused sick, special sick, or personal leave. Payment for accrued but unused vacation continues to be limited to two hundred twenty-five (225) hours in accordance with 31 IAC 1-9-3(f) or 31 IAC 2-11-3(f). *(State Personnel Department; 31 IAC 5-6-1)*

**31 IAC 5-6-2 Restrictions**

Authority: IC 4-15-1.8-6; IC 4-15-1.8-7; IC 5-10-1.1-7.5

Affected: IC 5-10-1.1; IC 5-10-12-3

**Sec. 2.** The provisions of this rule are subject to any restrictions imposed by the Internal Revenue Service on the plan adopted for this purpose by the Indiana deferred compensation committee. *(State Personnel Department; 31 IAC 5-6-2)*

SECTION 8. THE FOLLOWING ARE REPEALED: 31 IAC 1-12.1; 31 IAC 2-17.1; 31 IAC 4.

SECTION 9. SECTIONS 1 through 8 of this document take effect December 31, 2002.

**Notice of Public Hearing**

*Under IC 4-22-2-24, notice is hereby given that on July 31, 2002 at 9:00 a.m., at the Indiana Government Center-South, 402 West Washington Street, Room W161, Indianapolis, Indiana the State Personnel Department will hold a public hearing on proposed amendments to the merit and non-merit personnel rules and the adoption of a new rule. This rule promulgation hearing concerns implementation of Public Law 184-2001, which establishes a new program to convert state employees' excess accrued leave into the Indiana deferred compensation matching plan. Copies of these rules are now on file at the Indiana Government Center-South, 402 West Washington Street, Room W161 and Legislative Services Agency, One North Capitol, Suite 325, Indianapolis, Indiana and are open for public inspection.*

D. Sue Roberson  
State Personnel Director  
State Personnel Department

**TITLE 45 DEPARTMENT OF STATE REVENUE**

**Proposed Rule**  
LSA Document #02-40

DIGEST

Amends 45 IAC 18 concerning charity gaming. Repeals 45 IAC 18-1-2, 45 IAC 18-1-3, 45 IAC 18-1-4, 45 IAC 18-1-5, 45 IAC 18-1-6, 45 IAC 18-1-7, 45 IAC 18-1-8, 45 IAC 18-3-3, 45 IAC 18-6-1, and 45 IAC 18-6-2. Effective 30 days after filing with the secretary of state.

## Proposed Rules

45 IAC 18-1-2	45 IAC 18-1-33
45 IAC 18-1-3	45 IAC 18-1-34
45 IAC 18-1-4	45 IAC 18-1-35
45 IAC 18-1-5	45 IAC 18-1-36
45 IAC 18-1-6	45 IAC 18-1-37
45 IAC 18-1-7	45 IAC 18-1-38
45 IAC 18-1-8	45 IAC 18-1-39
45 IAC 18-1-9	45 IAC 18-1-40
45 IAC 18-1-10	45 IAC 18-1-41
45 IAC 18-1-11	45 IAC 18-1-42
45 IAC 18-1-12	45 IAC 18-1-43
45 IAC 18-1-13	45 IAC 18-2-1
45 IAC 18-1-14	45 IAC 18-2-2
45 IAC 18-1-15	45 IAC 18-2-3
45 IAC 18-1-16	45 IAC 18-2-4
45 IAC 18-1-17	45 IAC 18-3-1
45 IAC 18-1-18	45 IAC 18-3-2
45 IAC 18-1-19	45 IAC 18-3-3
45 IAC 18-1-20	45 IAC 18-3-4
45 IAC 18-1-21	45 IAC 18-3-5
45 IAC 18-1-22	45 IAC 18-3-6
45 IAC 18-1-23	45 IAC 18-3-7
45 IAC 18-1-24	45 IAC 18-3-8
45 IAC 18-1-25	45 IAC 18-4-1
45 IAC 18-1-26	45 IAC 18-4-2
45 IAC 18-1-27	45 IAC 18-5-2
45 IAC 18-1-28	45 IAC 18-6-1
45 IAC 18-1-29	45 IAC 18-6-2
45 IAC 18-1-30	45 IAC 18-6-3
45 IAC 18-1-31	45 IAC 18-7
45 IAC 18-1-32	45 IAC 18-8

SECTION 1. 45 IAC 18-1-9 IS ADDED TO READ AS FOLLOWS:

**45 IAC 18-1-9 “Affiliate” defined**

Authority: IC 4-32-7-3  
Affected: IC 4-32-6

Sec. 9. “Affiliate” means any person or entity directly or indirectly controlling, controlled by or under common control or ownership as the licensee or shares with the licensee a common board, directors, or officer. (*Department of State Revenue; 45 IAC 18-1-9*)

SECTION 2. 45 IAC 18-1-10 IS ADDED TO READ AS FOLLOWS:

**45 IAC 18-1-10 “Bingo card” and “bingo paper” defined**

Authority: IC 4-32-7-3  
Affected: IC 4-32-6

Sec. 10. “Bingo card” and “bingo paper” means permutations of letter and number combinations printed on reusable or nonreusable card or paper stock containing five (5) rows of five (5) squares, each imprinted with randomly

placed numbers, one (1) through seventy-five (75), except for the center square that may be a free space, and a set of designators, similarly numbered, that are contained in a selection device. The letters “B-I-N-G-O” must also be imprinted, in order above each of the five (5) columns. A serial number consisting of at least five (5) characters must be printed on each item manufactured and sold. (*Department of State Revenue; 45 IAC 18-1-10*)

SECTION 3. 45 IAC 18-1-11 IS ADDED TO READ AS FOLLOWS:

**45 IAC 18-1-11 “Bingo equipment” defined**

Authority: IC 4-32-7-3  
Affected: IC 4-32-6

Sec. 11. “Bingo equipment” means all paraphernalia used to conduct the game, including the following:

- (1) Random number selection equipment.
- (2) Designators, such as bingo balls.
- (3) Designator receptacles.
- (4) Number display boards.
- (5) Dispensing devices.

The term does not include audio or video equipment, which plays no part in the conduct of the game other than communicating the progress of the game. The term does not include any computer or other technologic aid. (*Department of State Revenue; 45 IAC 18-1-11*)

SECTION 4. 45 IAC 18-1-12 IS ADDED TO READ AS FOLLOWS:

**45 IAC 18-1-12 “Bingo supplies” defined**

Authority: IC 4-32-7-3; IC 4-32-8-3  
Affected: IC 4-32-9

Sec. 12. “Bingo supplies” means:

- (1) bingo paper;
- (2) bingo cards;
- (3) concealed face bingo cards;
- (4) daubers; or
- (5) other devices designed to cover squares on bingo card or bingo paper.

(*Department of State Revenue; 45 IAC 18-1-12*)

SECTION 5. 45 IAC 18-1-13 IS ADDED TO READ AS FOLLOWS:

**45 IAC 18-1-13 “Calendar” defined**

Authority: IC 4-32-7-3; IC 4-32-8-3  
Affected: IC 4-32-9

Sec. 13. “Calendar” means a tabular register of days that does not cover less than one (1) calendar month or more than twelve (12) calendar months, and is used for a calendar raffle. (*Department of State Revenue; 45 IAC 18-1-13*)



SECTION 6. 45 IAC 18-1-14 IS ADDED TO READ AS FOLLOWS:

**45 IAC 18-1-14 “Calendar raffle” defined**

Authority: IC 4-32-7-3; IC 4-32-8-3  
Affected: IC 4-32-9

Sec. 14. “Calendar raffle” means a raffle in which a drawing is held and a prize awarded on each date specified in a calendar. (*Department of State Revenue; 45 IAC 18-1-14*)

SECTION 7. 45 IAC 18-1-15 IS ADDED TO READ AS FOLLOWS:

**45 IAC 18-1-15 “Charity game night” defined**

Authority: IC 4-32-7-3  
Affected: IC 4-32-6

Sec. 15. (a) “Charity game night” means an event where wagers are placed upon the following permitted games of chance through the use of imitation money:

- (1) A card game.
- (2) A dice game.
- (3) A roulette wheel.
- (4) A spindle.

(b) The term does not include an event where wagers are placed on:

- (1) bookmaking;
- (2) a slot machine;
- (3) a one-ball machine;
- (4) a pinball machine that awards anything other than an immediate and unrecorded right of replay;
- (5) a policy or numbers game; or
- (6) a banking or percentage game played with cards or counters.

(*Department of State Revenue; 45 IAC 18-1-15*)

SECTION 8. 45 IAC 18-1-16 IS ADDED TO READ AS FOLLOWS:

**45 IAC 18-1-16 “Computer or other technologic aid” defined**

Authority: IC 4-32-7-3; IC 4-32-8-3  
Affected: IC 4-32-9

Sec. 16. “Computer or other technologic aid” means either of the following:

- (1) A device that uses electronic or electromagnetic media to assist a player by projecting the outcome of the game, keeping track of the number and letter combinations called in bingo, analyzing the probability of the occurrence of an event relating to the bingo, or analyzing the strategy for playing bingo.
- (2) A device, such as a computer, telephone, cable, television, satellite, the Internet, or device that broadcasts the playing of a game or links gaming events.

(*Department of State Revenue; 45 IAC 18-1-16*)

SECTION 9. 45 IAC 18-1-17 IS ADDED TO READ AS FOLLOWS:

**45 IAC 18-1-17 “Concealed face bingo card” defined**

Authority: IC 4-32-7-3  
Affected: IC 4-32-9

Sec. 17. “Concealed face bingo card” means a nonreusable bingo card constructed to conceal the card face. This type of card is commonly referred to under trade names, such as the following:

- (1) Tear-Open.
- (2) Bonanza Bingo.
- (3) Bull’s-eye.
- (4) Fortune Cards.

A serial number consisting of at least five (5) characters must be printed on each item manufactured and sold. (*Department of State Revenue; 45 IAC 18-1-17*)

SECTION 10. 45 IAC 18-1-18 IS ADDED TO READ AS FOLLOWS:

**45 IAC 18-1-18 “Conduct prejudicial to the public confidence in the department” defined**

Authority: IC 4-32-7-3  
Affected: IC 4-32-1; IC 4-32-9; IC 35-45-5-1

Sec. 18. “Conduct prejudicial to the public confidence in the department”, as used in this article and in IC 4-32-1, means conduct that gives the appearance of impropriety, including the failure to file tax returns, conducting a gaming event without a license, sports betting, operating a gambling device, using or possessing a computer or other technologic aid, as defined in section 16 of this rule, or any other activity illegal under IC 35-45-5-1 et seq. (*Department of State Revenue; 45 IAC 18-1-18*)

SECTION 11. 45 IAC 18-1-19 IS ADDED TO READ AS FOLLOWS:

**45 IAC 18-1-19 “Deal” defined**

Authority: IC 4-32-7-3  
Affected: IC 4-32-9

Sec. 19. “Deal” means each separate package, or series of packages, consisting of one (1) game of pull-tabs or tip boards with the same serial number. (*Department of State Revenue; 45 IAC 18-1-19*)

SECTION 12. 45 IAC 18-1-20 IS ADDED TO READ AS FOLLOWS:

**45 IAC 18-1-20 “Dispensing device” defined**

Authority: IC 4-32-7-3  
Affected: IC 4-32-9

Sec. 20. “Dispensing device” means a mechanical or electromechanical device with one (1) or more stacking

## Proposed Rules

columns that dispense a pull-tab only after a player inserts an appropriate amount of coin or currency. This does not include any device that electronically generates a pull-tab. (Department of State Revenue; 45 IAC 18-1-20)

SECTION 13. 45 IAC 18-1-21 IS ADDED TO READ AS FOLLOWS:

### 45 IAC 18-1-21 "Door prize" defined

Authority: IC 4-32-7-3  
Affected: IC 4-32-9

Sec. 21. "Door prize" means a prize awarded to a person based solely upon the person's attendance at an event or the purchase of a ticket to attend an event and is not premised in whole or in part on the placing of a wager. No organization shall award a door prize when the award of a prize is determined, in whole or in part on a sporting event. (Department of State Revenue; 45 IAC 18-1-21)

SECTION 14. 45 IAC 18-1-22 IS ADDED TO READ AS FOLLOWS:

### 45 IAC 18-1-22 "Existence" defined

Authority: IC 4-32-7-3  
Affected: IC 4-32-9; IC 6-2.1-3; IC 6-3-2

Sec. 22. "Existence" means the organization's active demonstrable support of its stated purpose or mission in addition to any actual corporate existence, including maintaining its gross income tax exemption under IC 6-2.1-3, maintaining its adjusted gross income tax exemption under IC 6-3-2, and being current in all tax filings. (Department of State Revenue; 45 IAC 18-1-22)

SECTION 15. IAC 18-1-23 IS ADDED TO READ AS FOLLOWS:

### 45 IAC 18-1-23 "Festival" defined

Authority: IC 4-32-7-3  
Affected: IC 4-32-9

Sec. 23. "Festival" means an event where a qualified organization is authorized to conduct bingo events, charity game nights, one (1) raffle event, door prize events, and sell pull-tabs, punchboards, and tip boards. (Department of State Revenue; 45 IAC 18-1-23)

SECTION 16. 45 IAC 18-1-24 IS ADDED TO READ AS FOLLOWS:

### 45 IAC 18-1-24 "Flare" defined

Authority: IC 4-32-7-3  
Affected: IC 4-32-9

Sec. 24. (a) "Flare" means the card enclosed with each deal of pull-tabs that has the following information:

- (1) The name of the game.
- (2) The manufacturer's name or distinctive logo.

(3) The game form number.

(4) The prize structure for the game, which includes the number of winning pull-tabs by denomination and their respective winning symbol or symbols or number or numbers combination.

(5) The cost per ticket.

(6) The serial number of the game.

(7) The winning number or symbol for at least the top three (3) winning tiers set out in a manner that each prize may be marked off as the prize is won and awarded.

(b) In addition to the requirements of the foregoing, all pull-tabs manufactured or distributed for sale in Indiana must meet the "Standards on Pull-Tabs" adopted by the North American Gaming Regulators Association on October 12, 1991, and as later amended. (Department of State Revenue; 45 IAC 18-1-24)

SECTION 17. 45 IAC 18-1-25 IS ADDED TO READ AS FOLLOWS:

### 45 IAC 18-1-25 "In existence for at least twenty-five (25) years" defined

Authority: IC 4-32-7-3  
Affected: IC 4-32-9

Sec. 25. "In existence for at least twenty-five (25) years" means that the nationally recognized charitable organization must have been continuously incorporated or legally authorized to do business for at least twenty-five (25) years as a charitable organization, in each of at least three (3) states, including Indiana. (Department of State Revenue; 45 IAC 18-1-25)

SECTION 18. 45 IAC 18-1-26 IS ADDED TO READ AS FOLLOWS:

### 45 IAC 18-1-26 "In good standing with the department" defined

Authority: IC 4-32-7-3  
Affected: IC 4-32-9

Sec. 26. "In good standing with the department" means an individual or organization that has:

- (1) made all required tax filings or any other required filings with the department; and
- (2) no outstanding liabilities with the department.

(Department of State Revenue; 45 IAC 18-1-26)

SECTION 19. 45 IAC 18-1-27 IS ADDED TO READ AS FOLLOWS:

### 45 IAC 18-1-27 "Location" defined

Authority: IC 4-32-7-3  
Affected: IC 4-32-9

Sec. 27. "Location" means the street address and mailing address. It cannot include a post office box and is not

connected by a common roof or wall with another structure where gaming activities occur. (*Department of State Revenue; 45 IAC 18-1-27*)

SECTION 20. 45 IAC 18-1-28 IS ADDED TO READ AS FOLLOWS:

**45 IAC 18-1-28 “Member” defined**

Authority: IC 4-32-7-3; IC 4-32-8-3  
Affected: IC 4-32-9

Sec. 28. “Member” means an individual who is qualified for membership in an organization pursuant to its bylaws, articles of incorporation, charter, or rules, who is entitled to vote in the election of the organization’s officers or board members or both, and who is eligible to be elected as an officer or board member or both, and to participate in the determination of the policies of the organization. The individual must be able to show continuous active participation in the organization’s stated purpose or mission, including, but not limited to, the contribution of time, money, or talent to the organization and attends regular meetings of the organization. (*Department of State Revenue; 45 IAC 18-1-28*)

SECTION 21. 45 IAC 18-1-29 IS ADDED TO READ AS FOLLOWS:

**45 IAC 18-1-29 “Nationally recognized charitable organization” defined**

Authority: IC 4-32-7-3; IC 4-32-8-3  
Affected: IC 4-32-9

Sec. 29. “Nationally recognized charitable organization” means an organization that:

- (1) possesses a determination letter or a ruling from the Internal Revenue Service stating that the organization is currently exempt from taxation under 26 U.S.C. 501, or is listed in Internal Revenue Service Publication 78 (Cumulative List of Organizations);
- (2) has current exempt status with the department;
- (3) is organized primarily for charitable purposes;
- (4) is incorporated or legally authorized to do business in at least three (3) states, including Indiana; and
- (5) has a national membership of at least five thousand (5,000) people.

(*Department of State Revenue; 45 IAC 18-1-29*)

SECTION 22. 45 IAC 18-1-30 IS ADDED TO READ AS FOLLOWS:

**45 IAC 18-1-30 “Operator” defined**

Authority: IC 4-32-7-3; IC 4-32-8-3  
Affected: IC 4-32-9

Sec. 30. “Operator” means a member of a qualified organization who is:

- (1) an Indiana resident;
- (2) in good standing with the department; and
- (3) in addition to the foregoing, the following individuals are also operators:

(A) A bartender licensed with the alcohol and tobacco commission if the bartender sells only pull-tabs, tip boards, or punchboards.

(B) Any person who accounts for money received at the charity gaming event.

(C) Any person who keeps records of the charity gaming event.

(D) Any person who announces the letter-number combination at a bingo event.

(*Department of State Revenue; 45 IAC 18-1-30*)

SECTION 23. 45 IAC 18-1-31 IS ADDED TO READ AS FOLLOWS:

**45 IAC 18-1-31 “Pull-tab” defined**

Authority: IC 4-32-7-3; IC 4-32-8-3  
Affected: IC 4-32-9

Sec. 31. “Pull-tab” means a game conducted in the following manner:

(1) A single folded or banded ticket or a two-ply card with perforated break-open tabs is bought by a player.

(2) The face of each card is initially covered or otherwise hidden from view, concealing a number, letter, symbol, or set of letters or symbols.

(3) In each set of tickets or cards, a designated number of tickets or cards have been randomly designated in advance as winners.

(4) Winners or potential winners, if the game includes the use of a seal, are determined by revealing the faces of tickets or cards. The player may be required to sign the player’s name on numbered lines provided, if a seal is used.

(5) The player with a winning pull-tab ticket or numbered line receives the prize stated on the flare from the qualified organization.

(6) A serial number consisting of at least five (5) characters must be printed on each item manufactured and sold.

(7) A pull-tab may not be electronically generated.

(*Department of State Revenue; 45 IAC 18-1-31*)

SECTION 24. 45 IAC 18-1-32 IS ADDED TO READ AS FOLLOWS:

**45 IAC 18-1-32 “Punchboard” defined**

Authority: IC 4-32-7-3  
Affected: IC 4-32-9

Sec. 32. “Punchboard” means a card or board that contains a grid or section that hides the random opportunity to win a prize based on the results of punching a single hole to reveal a symbol or prize amount. A serial number

## Proposed Rules

consisting of at least five (5) characters must be printed on each item manufactured and sold. A punchboard may not be electronically generated. (*Department of State Revenue; 45 IAC 18-1-32*)

SECTION 25. 45 IAC 18-1-33 IS ADDED TO READ AS FOLLOWS:

### 45 IAC 18-1-33 “Premises” defined

Authority: IC 4-32-7-3  
Affected: IC 4-32-9

Sec. 33. “Premises” means a building or a distinct portion of a building where charity gaming is conducted. A portion of a building is considered distinct if it has a separate mailing address and is not connected by a common roof or wall with another structure where gaming activities occur. (*Department of State Revenue; 45 IAC 18-1-33*)

SECTION 26. 45 IAC 18-1-34 IS ADDED TO READ AS FOLLOWS:

### 45 IAC 18-1-34 “Raffle” defined

Authority: IC 4-32-7-3; IC 4-32-8-3  
Affected: IC 4-32-9

Sec. 34. “Raffle” means a game in which one (1) or more persons who have purchased a raffle ticket win the prize or prizes. The winner or winners of the raffle are determined by drawing a ticket stub from a receptacle holding ticket stubs corresponding to all tickets sold for the raffle. The winning of a prize in a raffle cannot be premised in whole or in part on a sporting event. (*Department of State Revenue; 45 IAC 18-1-34*)

SECTION 27. 45 IAC 18-1-35 IS ADDED TO READ AS FOLLOWS:

### 45 IAC 18-1-35 “Revoke” defined

Authority: IC 4-32-7-3  
Affected: IC 4-32-9

Sec. 35. “Revoke” means that a qualified organization cannot conduct any gaming events, or hold a license for gaming events. The revocation begins at the time the organization receives notice from the department, or when the organization exhausts all administrative and legal remedies, whichever is later. (*Department of State Revenue; 45 IAC 18-1-35*)

SECTION 28. 45 IAC 18-1-36 IS ADDED TO READ AS FOLLOWS:

### 45 IAC 18-1-36 “Seal card” defined

Authority: IC 4-32-7-3  
Affected: IC 4-32-9

Sec. 36. “Seal card” means a board or placard used with

pull-tabs that contains a seal or seals, which when removed or opened reveal predesignated winning numbers, letter, symbols, or monetary denominations. The seal card serves as the game flare and must contain the information required in section 24 of this rule unless the manufacturer provides an additional flare containing the required information. A seal card may not be electronically generated. (*Department of State Revenue; 45 IAC 18-1-36*)

SECTION 29. 45 IAC 18-1-37 IS ADDED TO READ AS FOLLOWS:

### 45 IAC 18-1-37 “Serves a majority of counties in Indiana” defined

Authority: IC 4-32-7-3  
Affected: IC 4-32-9

Sec. 37. “Serves a majority of counties in Indiana” means that a nationally recognized charitable organization must do the following:

- (1) Maintain an office with a mailing address, which is open for business during posted business hours.
- (2) Directly assist selected individuals or conducts other charitable activity.

Both services must be continuously available and ongoing in at least forty-seven (47) Indiana counties. (*Department of State Revenue; 45 IAC 18-1-37*)

SECTION 30. 45 IAC 18-1-38 IS ADDED TO READ AS FOLLOWS:

### 45 IAC 18-1-38 “Suspend” defined

Authority: IC 4-32-7-3; IC 4-32-8-3  
Affected: IC 4-32-9

Sec. 38. “Suspend” means that the qualified organization cannot conduct any gaming events or hold a license for a period of time specified by the department. The period of suspension begins at the time the organization receives notice from the department or when the organization exhausts all administrative and legal remedies, whichever is later. (*Department of State Revenue; 45 IAC 18-1-38*)

SECTION 31. 45 IAC 18-1-39 IS ADDED TO READ AS FOLLOWS:

### 45 IAC 18-1-39 “Tip board” defined

Authority: IC 4-32-7-3  
Affected: IC 4-32-9

Sec. 39. “Tip board” means a board, placard, or other device containing a seal that:

- (1) conceals the winning number or symbol; and
- (2) serves as the game flare for a tip board game.

(*Department of State Revenue; 45 IAC 18-1-39*)

SECTION 32. 45 IAC 18-1-40 IS ADDED TO READ AS FOLLOWS:

**45 IAC 18-1-40 "Tip board ticket" defined**

Authority: IC 4-32-7-3; IC 4-32-8-3  
Affected: IC 4-32-9

Sec. 40. "Tip board ticket" is a single folded or banded ticket, or multi-ply card, the face of which is initially covered or otherwise hidden from view to conceal a number, symbol, or set of symbols, some of which have been designated in advance and at random as prize winners. A tip board ticket may not be electronically generated. (Department of State Revenue; 45 IAC 18-1-40)

SECTION 33. 45 IAC 18-1-41 IS ADDED TO READ AS FOLLOWS:

**45 IAC 18-1-41 "Value" defined**

Authority: IC 4-32-7-3  
Affected: IC 4-32-6

Sec. 41. "Value", when used in connection with the word "prize" means the retail price of the property given as the prize when the prize is other than money. This definition applies whether the property given as the prize is purchased or donated for the event. If the prize given is money, then the value of the prize is the sum of money regardless of any losses by the player. (Department of State Revenue; 45 IAC 18-1-41)

SECTION 34. 45 IAC 18-1-42 IS ADDED TO READ AS FOLLOWS:

**45 IAC 18-1-42 "Wager" defined**

Authority: IC 4-32-7-3; IC 4-32-8-3  
Affected: IC 4-32-9

Sec. 42. "Wager" means risking money or other property for gain, contingent in whole or in part upon chance, but it does not include participating in a bona fide contests of skill, speed, strength, or endurance in which awards are made only to entrants. (Department of State Revenue; 45 IAC 18-1-42)

SECTION 35. 45 IAC 18-1-43 IS ADDED TO READ AS FOLLOWS:

**45 IAC 18-1-43 "Worker" defined**

Authority: IC 4-32-7-3; IC 4-32-8-3  
Affected: IC 4-32-9

Sec. 43. (a) "Worker" means a member of a qualified organization who is:

- (1) an Indiana resident; and
- (2) in good standing with the department.

(b) The term does not include security personnel who are licensed law enforcement officers in Indiana, or are licensed private detectives in Indiana. (Department of State Revenue; 45 IAC 18-1-43)

SECTION 36. 45 IAC 18-2-1 IS AMENDED TO READ AS FOLLOWS:

**45 IAC 18-2-1 Application by qualified organization**

Authority: IC 4-32-7-3; IC 4-32-8-3  
Affected: IC 4-32-9-18

Sec. 1. (a) To obtain a license to operate an allowable event, a qualified organization must submit a written application on a form prescribed by the department.

(b) The application shall include the following information:

- (1) The name and ~~address~~ **location** of the organization.
- (2) The names, ~~and~~ addresses, **and Social Security number** of the officers of the organization.
- (3) The type of event ~~that~~ the organization proposes to conduct.
- (4) The location ~~at which~~ **and mailing address** where the organization will conduct the event.
- (5) The dates and time for the proposed event.
- (6) Sufficient facts for the department to determine that the organization is a qualified organization, including, but not limited to, the following:

(A) The organization's ~~not-for-profit~~ **Indiana Taxpayer Identification** number.

(B) A letter from the Internal Revenue Service stating that the organization is exempt from taxation under Section 501 of the Internal Revenue Code.

(C) Proof that the organization has been in **continuous** existence for five (5) or more years **composed of no fewer than three (3) documents per year received from a source outside of the organization, including, but not limited to, banking statements or utility bills, and two (2) documents per year originating from within the organization including, but not limited to, minutes of meetings. All documents must contain the date in which the document was generated.**

(D) A copy of the organization's **articles of incorporation and any** bylaws. ~~or articles of incorporation.~~

(E) The name of each proposed operator, and sufficient facts to determine that ~~the~~ **each** person is qualified to be an operator, **including, but not limited to, each person's address, date of birth, length of membership, and Social Security number.**

(F) A ~~sworn~~ statement **made under the penalties of perjury** by the presiding officer and secretary of the organization attesting to the eligibility of the organization, including the nonprofit character of the organization.

(G) A **bona fide civic organization applying for an additional charity game night or festival night under IC 4-32-9-18(c) must have a 501(c)(4) determination by the Internal Revenue Service and be registered as a civic organization with the department by providing copies of the appropriate documents to the department. An organization that is holding an annual convention and**

## Proposed Rules

exceeds the two hundred dollar (\$200) rent limitation must submit the following to the department:

- (i) A convention brochure.
- (ii) Newsletter distributed to its membership announcing the annual meeting.
- (iii) Any registration forms for the convention.
- (iv) Minutes of meetings showing the discussion and planning of the convention.

(H) Proof that the organization is in good standing with the department.

(I) A current copy of the organization's membership roster, or other proof of membership.

(J) A copy of the lease if the organization is renting the premises where the gaming activity will occur. The lease must be between the organization and the owner of the premises. The owner of the premises shall be determined by the address on the property tax rolls of the county assessor.

~~(G)~~ (K) Any other information that the department may require.

(c) A license is not required if the following conditions are met:

(1) ~~A fee~~ The award of the prize is not charged for the event. ~~premised in whole or in part on the placing of a wager.~~

(2) The value of all prizes awarded does not exceed ~~one hundred one thousand~~ dollars ~~(\$100)~~ (\$1,000) for a single event and no more than three thousand dollars (\$3,000) in a calendar year. An organization:

(A) must file on forms prescribed by the department prior to holding an unlicensed event; and

(B) may hold multiple drawings, such as 50/50 or "game ball" raffles, as unlicensed events if, in addition to the forgoing, the organization provides the department with the following additional information on forms prescribed by the department:

- (i) Specific dates of the drawings.
- (ii) The location of the drawings.
- (iii) A description of the type and amount of prizes being awarded to winners.

(d) Although a license is not required under subsection (c), a qualified organization is required to obtain an exemption a nonlicense approval letter from the department before holding such an event. The department may issue the exemption letter nonlicense approval on an annual basis if the qualified organization shows that it holds such an event on a continuous basis throughout the year. A readable photocopy of the nonlicense approval letter is to be prominently displayed at the facility where the event is being held. The original letter of registration of the event must be available for inspection upon request at all times.

(e) If an event meets the conditions required by subsection (c)

and an exemption a nonlicense approval letter is issued under subsection (d), 45 IAC 18-3-2 shall not apply to the conducting of that event. (*Department of State Revenue; 45 IAC 18-2-1; filed Jan 8, 1993, 9:00 a.m.: 16 IR 1369*)

SECTION 37. 45 IAC 18-2-2 IS AMENDED TO READ AS FOLLOWS:

### 45 IAC 18-2-2 Application by a manufacturer or distributor

Authority: IC 4-32-7-3; IC 4-32-8-3  
Affected: IC 4-32

Sec. 2. (a) An entity is required to must be licensed to manufacture, distribute, or sell supplies, devices, or equipment to be used in charity gaming in Indiana. To obtain an annual license, a manufacturer or distributor must submit a written application on a form prescribed by the department.

(b) The manufacturer's application shall include the following information:

(1) The name and address of the applicant, and the name and address of each of its separate locations where items are manufactured.

(2) The name and home address of all the owners of the applicant's business if it is not a corporation and, if it is a corporation, the name and address of the officers of the corporation and of each person owning at least ten percent (10%) of any class of stock of the corporation.

(3) The name, business address, and home address of the registered agent for service in Indiana if the applicant is a corporation not domiciled in Indiana.

(4) Whether the applicant or any person required to be named in the application is an owner, officer, director, or employee of any other entity that would be licensed under this rule.

(5) A full description of the type of gaming supplies or related equipment that will be manufactured.

(6) The name of each state where the applicant has been licensed to manufacture, supply, or distribute gaming supplies or related equipment, the license numbers, the period of time licensed, and whether or not a license has ever been suspended, revoked, or voluntarily forfeited, and the reason for that action.

(c) A distributor must purchase all supplies and equipment to be used in charity gaming in Indiana from a licensed manufacturer or another licensed distributor. The distributor's application shall include the following information:

(1) The full name and address of the applicant.

(2) The name and address of each location operated by the distributor from which bingo supplies are stored.

(3) The name and address of each owner, if the applicant is not a corporate distributor.

(4) The name and address of each shareholder who owns ten percent (10%) or more of any class of stock.

(5) The name and address of the registered agent for service

## Proposed Rules

in Indiana, if it is a corporation not domiciled in Indiana.  
 (6) A full description of the type of gaming supplies that will be distributed.  
 (7) The name of each state where the applicant has been a licensed distributor, the license number, the period of time licensed, and whether or not a license has ever been suspended or revoked, and the reason for that action.  
 (8) The name and address of every manufacturer from which purchases are made to be distributed in Indiana.

(d) An entity that ~~wishes to both manufacture manufactures~~ and ~~distribute distributes~~ supplies, devices, or equipment to be used in charity gaming in Indiana must possess a manufacturer's license and a distributor's license.

**(e) A qualified organization that holds a current charity gaming license may sell surplus bingo equipment if it meets the following conditions:**

- (1) It has prior written approval from the department.**
- (2) The bingo equipment was used by the organization in gaming events.**
- (3) It has not sold any equipment under this exception in the prior twelve (12) calendar months.**

*(Department of State Revenue; 45 IAC 18-2-2; filed Jan 8, 1993, 9:00 a.m.: 16 IR 1370)*

SECTION 38. 45 IAC 18-2-3 IS AMENDED TO READ AS FOLLOWS:

### 45 IAC 18-2-3 License fees

Authority: IC 4-32-7-3; IC 4-32-8-3

Affected: IC 4-32-9; IC 4-32-11-1; IC 4-32-11-3

Sec. 3. (a) Except for the renewal fee for an annual bingo license, all license fees must be paid at the time the application is submitted to the department. The renewal fee for an annual bingo license must be paid ~~within thirty (30) days after the end of the previous license period: by the tenth day of the month in which the license expires.~~

(b) The annual license fee for a manufacturer is three thousand dollars (\$3,000).

(c) The annual license fee for a distributor is two thousand dollars (\$2,000).

~~(d) The initial fee on each separate license held by a qualified organization is twenty-five dollars (\$25):~~

~~(e) (d) The renewal fee on each separate license held by a qualified organization is based on the total gross receipts from allowable events and related activities in the preceding year or, if the qualified organization held a license under IC 4-32-9-6 through IC 4-32-9-10, the total gross receipts from the preceding event and related activities. according to the following schedule:~~

At Least	Gross Receipts But Less Than	Renewal Fee
\$0	\$15,000	\$25
\$15,000	\$25,000	\$75
\$25,000	\$50,000	\$200
\$50,000	\$75,000	\$350
\$75,000	\$100,000	\$600
\$100,000	\$150,000	\$900
\$150,000	\$200,000	\$1,200
\$200,000	\$250,000	\$1,500
\$250,000	\$300,000	\$1,800
\$300,000	\$400,000	\$2,500
\$400,000	\$500,000	\$3,250
\$500,000	\$750,000	\$5,000
\$750,000	\$1,000,000	\$6,750
\$1,000,000	\$1,250,000	\$8,500
\$1,250,000	\$1,500,000	\$10,000
\$1,500,000	\$1,750,000	\$12,000
\$1,750,000	\$2,000,000	\$14,000
\$2,000,000	\$2,250,000	\$16,250
\$2,250,000	\$2,500,000	\$18,500
\$2,500,000	\$3,000,000	\$22,500
\$3,000,000		\$25,000

~~(f) (e) If an organization does not renew its license, but an auxiliary or affiliated group applies for a license, the application shall be considered a renewal and subject to the fees stated in subsection (d): IC 4-32-11-3.~~

~~(g) (f) If an organization held a special license for a single event, the license fee for a subsequent similar event and wishes to hold the same type of event at a later time, then the license fee for the subsequent event is based on the gross receipts from the preceding allowable event and related activities even if the subsequent event is held during the same year of operation: regardless of the length of time between events.~~

~~(h) (g) The gross receipts from the sale of pull-tabs, punchboards, and tip boards are included in total gross receipts for purposes of the renewal fee. Sales of other tangible personal property sold specifically at the event will be included in gross receipts as a related activity. For example, the qualified organization sells key chains, hot dogs, and drinks in the same area as the event being held. This would be considered a related activity because the sale took place as a result of the allowable event.~~

**(h) The department may not issue a proposed assessment under IC 4-32-11-1 more than three (3) years after the date the application was filed. However, the department may issue a proposed assessment up to six (6) years after the date the application was filed if the:**

- (1) applicant fails to pay the entire license fee; and**

## Proposed Rules

**(2) omission was greater than or equal to twenty-five percent (25%) of the required fee.**

*(Department of State Revenue; 45 IAC 18-2-3; filed Jan 8, 1993, 9:00 a.m.: 16 IR 1370)*

SECTION 39. 45 IAC 18-2-4 IS AMENDED TO READ AS FOLLOWS:

### 45 IAC 18-2-4 Charity gaming licenses

Authority: IC 4-32-7-3; IC 4-32-8-3

Affected: IC 4-32

Sec. 4. (a) A readable photocopy of a license is required to be prominently displayed at the facility **on each wall** where the event is being held **in such a manner that it can be clearly read by the players**. The original license must be available for inspection upon request at all times. In addition to the photocopy, a legible sign of adequate dimension must be prominently posted during an event giving the name of the qualified organization, its license number, and the expiration date of the license.

(b) Application for the following licenses may be made by a qualified organization:

(1) A bingo license which permits the licensee to conduct up to three (3) bingo events per calendar week. This license permits the licensee to conduct door prize drawings and sell pull-tabs, punchboards, and tip boards at the bingo event. An organization cannot have more than one (1) allowable event per day. The bingo license is in effect for one (1) year from the date of issuance.

(2) A special bingo license which permits the licensee to conduct one (1) bingo event at only one (1) time and location. This license can be renewed at the discretion of the department upon reapplication and payment of the license fee based on the preceding event.

(3) A charity game night license, which permits the licensee to conduct one (1) charity game night at one (1) location. This license permits the licensee to conduct a card game, a dice game, a roulette wheel, and a spindle. This license also permits door prize drawings and the sale of pull-tabs, punchboards, and tip boards. An organization is limited to four (4) charity game nights per calendar year.

(4) A raffle license which permits the licensee to conduct a raffle at only one (1) time and location. This license also permits the licensee to conduct door prize drawings and to sell pull-tabs, punchboards, and tip boards. ~~However, a license is not required if the total market value of the prizes awarded at the raffle event does not exceed one thousand dollars (\$1,000).~~

(5) A door prize license which permits the licensee to conduct one (1) door prize event and to sell pull-tabs, punchboards, and tip boards. ~~However, a license is not required if the total market value of the prizes awarded at the door prize event does not exceed one thousand dollars (\$1,000).~~

(6) A festival license which permits the licensee to conduct bingo events, charity game nights, one (1) raffle event, door

prize events, and sell pull-tabs, punchboards, and tip boards at the festival. The festival can only be held once a calendar year and cannot exceed four (4) consecutive days. The raffle event conducted at a festival is not subject to any prize limitations. If the organization has a festival, the organization is precluded from conducting any further charity game nights during the year, unless the festival license is issued for less than four (4) days. Also, a festival license will be issued for less than four (4) days if an organization has previously been granted one (1) or more charity game night licenses.

(c) A qualified organization may hold more than one (1) license at the same time. However, an organization cannot have a bingo event and a raffle at the same event without permission from the department. A bingo event and raffle event may only be held together once a calendar year. *(Department of State Revenue; 45 IAC 18-2-4; filed Jan 8, 1993, 9:00 a.m.: 16 IR 1371; errata filed Feb 12, 1993, 5:00 p.m.: 16 IR 1832)*

SECTION 40. 45 IAC 18-3-1 IS AMENDED TO READ AS FOLLOWS:

### 45 IAC 18-3-1 Allowable events

Authority: IC 4-32-7-3; IC 4-32-8-3

Affected: IC 4-32

Sec. 1. (a) A qualified organization must hold an allowable event in the county where its principal office is located. **If a qualified organization has a principal office in more than one (1) county, the department will issue only one (1) license per day to that organization. A qualified organization that has a principal office in more than one (1) county must have an officer who lives in the county in which the proposed gaming event will be held, sign the application for a gaming event.**

(b) The following events are allowed:

(1) ~~As used in this article, Bingo. means a game conducted in the following manner:~~

~~(A) Each participant receives at least one (1) card; board; pad; or piece of paper marked off into twenty-five (25) squares that are arranged in five (5) vertical rows of five (5) squares each; with each row designated by a single letter; and each box containing a single numeral; from one (1) to seventy-five (75); except the center box; which is always marked with the word "free".~~

~~(B) As the caller of the game announces a letter and number combination; each player covers the square corresponding to the announced number; letter; or combination of numbers and letters.~~

~~(C) The winner of each game is the player who is the first to properly cover a predetermined and announced pattern of squares upon the card used by the player.~~

(2) A charity game night. ~~As used in this article, "charity game night" means an event at which wagers are placed upon the following permitted games of chance through the use of imitation money:~~



- (A) A card game.
- (B) A dice game.
- (C) A roulette wheel.
- (D) A spindle.

The term does not include an event at which wagers are placed on bookmaking; a slot machine; a one-ball machine; a pinball machine that awards anything other than an immediate and unrecorded right of replay; a policy or numbers game; or a banking or percentage game played with cards or counters.

(3) A door prize drawing. As used in this article, "door prize" means a prize awarded to a person based solely upon the person's attendance at an event or the purchase of a ticket to attend an event.

(4) A festival. As used in this article, "festival" means an event at which a qualified organization is authorized to conduct bingo events; charity game nights; one (1) raffle event; door prize events; and sell pull-tabs; punchboards; and tip boards.

(5) ~~A~~ **The** sale of pull-tabs. As used in this article, "pull-tab" means a game conducted in the following manner:

- (A) A single folded or banded ticket or a two (2) ply card with perforated break-open tabs is bought by a player from a qualified organization.
- (B) The face of each card is initially covered or otherwise hidden from view; concealing a number, letter, symbol, or set of letters or symbols.
- (C) In each set of tickets or cards, a designated number of tickets or cards have been randomly designated in advance as winners.
- (D) Winners or potential winners, if the game includes the use of a seal, are determined by revealing the faces of tickets or cards. The player may be required to sign the player's name on numbered lines provided, if a seal is used.
- (E) The player with a winning pull-tab ticket or numbered line receives the prize stated on the flare from the qualified organization. The prize must be clearly and fully described on the flare or on the game information side of the card.

(6) ~~A~~ **The** sale of punchboards. As used in this article, "punchboard" means a card or board that contains a grid or section that hides the random opportunity to win a prize based on the results of punching a single section to reveal a symbol or prize amount.

(7) A raffle event. As used in this article, "raffle" means the selling of tickets or chances to win a prize awarded through a random drawing.

(8) ~~A~~ **The** sale of tip boards. As used in this article, "tip board" means a board, placard, or other device that is marked off in a grid or columns; with each section containing a hidden number or other symbol that determines a winner. The prize and the price of each tip must be described on the board.

(c) A sale of pull-tabs, punchboards, or tip boards may be conducted by a qualified organization at any allowable event. Also, a qualified organization may sell pull-tabs, punchboards,

or tip boards at any time on the premises owned or leased by the organization and regularly used by the organization as long as the organization possesses a valid bingo license.

**(d) No organization can conduct any allowable event in which the winner of a prize is determined, in whole or in part on a sporting event.** (Department of State Revenue; 45 IAC 18-3-1; filed Jan 8, 1993, 9:00 a.m.: 16 IR 1372)

SECTION 41. 45 IAC 18-3-2 IS AMENDED TO READ AS FOLLOWS:

**45 IAC 18-3-2 Conducting an allowable event**

Authority: IC 4-32-7-3; IC 4-32-8-3  
 Affected: IC 4-32-8-1; IC 35-45-5-1

Sec. 2. (a) The qualified organization must **purchase obtain** all bingo supplies, devices, and equipment from an entity licensed by the department to sell, distribute, or manufacture the supplies. Pull-tabs, punchboards, and tip boards must be **purchased obtained** from a licensed entity, except for those purchased from the Hoosier Lottery.

(b) The purchase of Hoosier Lottery pull-tabs by the qualified organization is permitted, if the qualified organization is licensed by the Hoosier Lottery to sell the items. The provisions of IC 4-32 do not apply to the purchase and sale of Hoosier Lottery pull-tabs by a qualified organization.

(c) An organization cannot enter into an agreement with another person or entity to conduct the event for the organization.

(d) Only one (1) organization can conduct an event on the same day at the same location. An organization is limited to three (3) allowable events in a calendar week. An organization cannot lease its premises to another qualified organization if this would result in more than three (3) events being held on such premises during a calendar week. Unless otherwise authorized by the department, an organization is limited to one (1) allowable event each day. An event or events must not be held on more than two (2) consecutive days, except for a festival. An event that starts before midnight and continues after midnight is the same event for purposes of applying this article. Except for a festival, an event cannot be scheduled for more than eight (8) consecutive hours. There shall be a six (6) hour break between events, except for the sale of pull-tabs, punchboards, or tip boards. A charity game night cannot be held more than four (4) times in a calendar year.

(e) Rent paid **by any entity** for leased facilities **for a qualified event** cannot exceed two hundred dollars (\$200) per day and cannot be based on the revenue generated by the event. Additional moneys shall not be paid for utilities, janitorial expenses, security, set up and tear down expenses, or any other expenses. These expenses must be included in the two hundred

## Proposed Rules

dollar (\$200) rent limitation per day. The facility cannot be leased for more than two (2) days in a calendar week. A facility is owned when an organization holds a fee simple estate in the facility. A facility is leased when an organization enters into a written agreement to occupy the facility ~~which gives rise to the relationship of lessor and lessee, regardless of the terms of the lease.~~ **for a specific period.** The lease of a facility for an allowable event must be in writing, **must be between the owner of the facility and the qualified organization, and may not be a sublease.**

**(f) If an organization leases a facility by the year for the express purpose of holding the organization's meetings, conducting the organization's business, and carrying on all of the organization's other functions in addition to any charity gaming events, then the rent limitation of two hundred dollars (\$200) per day is applied to every day in which the organization is housed at the leased facility. The maximum amount of rent an organization can pay when it is housed in a facility where gaming is conducted is seventy-three thousand dollars (\$73,000) per year. An organization must be able to prove that the leased facility is used for multi-functions by producing sufficient evidence. The necessary evidence to prove multi-function use includes the following:**

- (1) Photographs of the interior and exterior of the facility.**
- (2) A blueprint or copy of the facilities floor plan.**
- (3) Calendars of events scheduled in the facility that are not gaming related.**
- (4) Videotaped activities, such as parties, receptions, and meetings being held in the facility.**
- (5) One (1) complete year of all incidental charges, if any, associated with the use of the facility in addition to the base rent, such as the following:**
  - (A) Utility bills.**
  - (B) Insurance premiums.**
  - (C) Property taxes.**
  - (D) Maintenance and repairs.**
  - (E) Any other expenses associated with the organization's use of the facility.**

**(g)** Except for a festival, an organization must not pay more than fifty dollars (\$50) in total for personal property that may be used by the organization to conduct the event. This includes the rental of tables, chairs, and related equipment owned and leased by the lessor who is leasing the facility to the qualified organization for an allowable event. The rental of tangible personal property cannot be based on the revenue generated by the event. For a festival event, the fifty dollar (\$50) limitation only applies to the rental of gambling related equipment and supplies.

**(h)** A qualified organization may advertise an allowable event **only through printed media, television, or radio broadcast media originating within Indiana, or on an**

**organization's own Internet page.** An advertisement in printed media must contain the name and license number, in bold print, of the organization conducting the event. An advertisement in **radio or television** broadcast media must announce, at the end of the advertisement, the name and license number of the organization conducting the event. A television announcement of the name and license number of the organization conducting the event may be in the form of an audio **or** a visual, or both. **Advertising is the only activity an organization may conduct on the Internet.**

**(i)** An organization cannot sell a pull-tab, punchboard, or tip board ticket for more than one dollar (\$1). **Pull-tabs cannot be sold in this state unless a flare accompanies the deal.**

**(j)** An organization may not permit a person under the age of eighteen (18) years of age to play or participate in an allowable event. However, a person under eighteen (18) years of age may play or participate in nongambling activities, such as ring toss, fishing, **or** ball throws, ~~etc.~~ associated with an allowable event. **A qualified organization is prohibited from allowing an individual under eighteen (18) years of age to serve food or drinks to participants in the area where the gaming is occurring, or to interact with participants still in the area where gaming was occurring regardless of whether the minor was employed by a third party caterer.** Also, an organization cannot pay the operator or workers of an allowable event, including tips from the players. A legible sign of adequate dimension must be prominently posted **on each wall so that players can reasonably read it** during an event stating that the operator and workers are not allowed to accept tips. An operator is the person responsible for conducting an allowable event for the qualified organization. A worker is a person who helps or participates in any manner in conducting an allowable event.

**(k)** The organization must use operators and workers who are ~~qualified~~ members of the organization. An ~~operator has to have been a member in good standing for at least one (1) year; and a worker has to have been a member in good standing for at least thirty (30) days. If the qualified organization has an auxiliary or affiliated group; and the auxiliary or affiliated group is not a licensed qualified organization; then members of the auxiliary or affiliated group will be considered members of the qualified organization for purposes of operating or working an allowable event.~~ **organization may not use more than three (3) security personnel.**

**(l)** A person cannot be an operator or a worker if that person has been convicted of a felony in the last ten (10) years. Also, an employee of the department or anyone living in the same household of such employee may not be an operator or a worker. Although the operator and the workers may not receive any payment for conducting or assisting at an allowable event, the organization is permitted to provide meals or a recognition

dinner for the operator and the workers. Neither the operator nor a worker is permitted to participate in the allowable event that is being held. Also, an operator is prohibited from being an operator for more than one (1) qualified organization in a calendar month.

(m) The prize limit for one (1) bingo game is one thousand dollars (\$1,000). The prize limit for a bingo event is six thousand dollars (\$6,000). However, the department may permit a qualified organization to conduct two (2) bingo events a year where the prize limit for the event is ten thousand dollars (\$10,000). Also, the value of all door prizes awarded at a bingo event may not exceed one thousand five hundred dollars (\$1,500).

(n) A raffle event that is not conducted at another allowable event is not subject to any prize limitations concerning the raffle. Generally, if the raffle event is conducted at another allowable event, the total prize for the raffle event may not exceed five thousand dollars (\$5,000). However, the department may allow a qualified organization to conduct a raffle event at another allowable event where the total prize for the raffle event may not exceed twenty-five thousand dollars (\$25,000). Also, if the raffle is conducted at a festival, it is not subject to any prize limitations concerning the raffle. The value of all door prizes awarded at a raffle event may not exceed one thousand five hundred dollars (\$1,500).

(o) The total prizes awarded for one (1) pull-tab, punchboard, or tip board game may not exceed two thousand dollars (\$2,000). The total prize, including the prize value of a seal if one is used, for one (1) ticket for a pull-tab, punchboard, or tip board may not exceed three hundred dollars (\$300).

(p) The value of all door prizes awarded at a door prize event may not exceed five thousand dollars (\$5,000). However, the department may permit a qualified organization to conduct one (1) door prize event a year where the total prize awarded may not exceed twenty thousand dollars (\$20,000).

(q) For the exemptions from normal prize limits provided by subsection (l), (m), or (o), a qualified organization must submit a written application on a form prescribed by the department stating the date, time, and location of the event at least ~~fifteen (15)~~ **forty-five (45)** days prior to the date of the event. The authorization to exceed the normal prize limits must be prominently displayed at the time and location of the event.

(r) All net proceeds from an allowable event must be used for the lawful purpose of the qualified organization.

**(s) An organization can only accept United States currency and coin from players when conducting an allowable event, and may not extend credit to any player.**

**(t) If an organization disposes of any unused bingo**

**supplies, punchboards, pull-tabs, or tip boards the organization must destroy the items by shredding or burning them. The organization must then notify the department that items were destroyed and must provide the following information:**

- (1) The date the items were destroyed.**
- (2) The manner of destruction.**
- (3) A description of the items destroyed.**
- (4) The quantity of items destroyed.**
- (5) The serial numbers of the items destroyed.**
- (6) The trade name of the items.**

**(u) If an organization has lost bingo supplies, through theft, fire, flood, or other disasters, then the organization must immediately notify the department in writing of such loss and provided the following information:**

- (1) The date the items were lost.**
- (2) The manner of loss, a description of the items lost.**
- (3) The serial numbers of the items lost.**
- (4) The trade name of the items.**
- (5) Copies of all insurance forms submitted for the loss.**
- (6) Any police department or fire department reports.**

**(v) The department may seize any of the following:**

- (1) Bingo supplies.**
- (2) Bingo equipment.**
- (3) Equipment used for a charity game night.**
- (4) Computer or other technologic aid.**
- (5) Pull-tabs.**
- (6) Punchboards.**
- (7) Tip boards.**
- (8) Any device under IC 35-45-5-1.**
- (9) Any other device, equipment, or implement used in making a wager.**

**(w) The department may destroy or otherwise dispose of the items in subsection (v) forty-five (45) days after the later of the following:**

- (1) The department sends notice to the operators of the gaming event where the items were seized.**
- (2) The owner of the items exhausts all administrative appeals under IC 4-32-8-1.**

*(Department of State Revenue; 45 IAC 18-3-2; filed Jan 8, 1993, 9:00 a.m.: 16 IR 1373; filed Jun 1, 1994, 5:00 p.m.: 17 IR 2231)*

SECTION 42. 45 IAC 18-3-4 IS ADDED TO READ AS FOLLOWS:

**45 IAC 18-3-4 Calendar raffle; sale of tickets, calendars, and drawings for prizes**

Authority: IC 4-32-7-3  
Affected: IC 4-32

**Sec. 4. (a) All calendars should be identical in form and include the following:**

## Proposed Rules

- (1) The number of the license issued by the department.
- (2) The name and address of the sponsoring organization.
- (3) The price of the calendar and the discounted price, if any, of multiple calendar purchases.
- (4) The place for the purchaser to enter his or her name and address.
- (5) The date, time, and place of the drawings.

(b) Each calendar sold by an organization shall include a separate identification number, printed on both the purchaser's and the organization's portion of the calendar, numbered consecutively in relation to the other calendars for the same drawing.

(c) No calendar may exceed ten dollars (\$10) in cost for each month covered by the calendar.

(d) No person may sell a calendar unless authorized by a licensed organization.

(e) Tickets for a calendar raffle may not be offered for sale more than one hundred eighty (180) days before the raffle drawing.

(f) A calendar relating to a specific calendar raffle may not be sold after a drawing has taken place for any date on the calendar.

(g) The calendar shall be printed with the prize amount for each date on which a prize will be awarded.

(h) A calendar may be sold that either designates a prize amount for every day in a calendar period, or for a smaller number of specifically designated days in a calendar period.

(i) The calendars sold for a specific calendar raffle shall have identical prize dates printed on all calendars sold.

(j) A licensed organization may not change any date on which a prize will be awarded, or the amount of the designated prize after the organization has begun the sale of calendars.

(k) A licensed organization shall conduct drawings for all designated prize dates and award the prize amount that is printed on the calendar for each date.

(l) The purchaser of a calendar need not be present at the drawing to win a prize.

(m) If a calendar raffle drawing is canceled, the organization shall refund the receipts to the calendar purchasers.

(n) The organization that holds a calendar raffle drawing shall furnish a list of prize winners to each calendar holder who provides the organization with a self-addressed stamped envelope and requests the list. (*Department of State Revenue; 45 IAC 18-3-4*)

SECTION 43. 45 IAC 18-3-5 IS ADDED TO READ AS FOLLOWS:

### 45 IAC 18-3-5 Replacement of tickets in the drawing container

Authority: IC 4-32-7-3  
Affected: IC 4-32

Sec. 5. A licensed organization shall place a ticket or stub that has been drawn for a specific date back into the container so that the purchaser of that ticket or stub will have a chance to win again on all subsequent drawing dates. (*Department of State Revenue; 45 IAC 18-3-5*)

SECTION 44. 45 IAC 18-3-6 IS ADDED TO READ AS FOLLOWS:

### 45 IAC 18-3-6 Refunds

Authority: IC 4-32-7-3  
Affected: IC 4-32

Sec. 6. (a) A licensed organization, which has sold a calendar for a specific calendar raffle and subsequently decides not to conduct one (1) or more drawings printed on the calendar, shall refund the complete purchase price to each purchaser.

(b) A licensed organization may not deduct from a refund to a purchaser a handling charge or other amount relating to the expense incurred by the organization in the sale of a calendar. (*Department of State Revenue; 45 IAC 18-3-6*)

SECTION 45. 45 IAC 18-3-7 IS ADDED TO READ AS FOLLOWS:

### 45 IAC 18-3-7 Use of proceeds

Authority: IC 4-32-7-3  
Affected: IC 4-32-9-16

Sec. 7. (a) In accordance with IC 4-32-9-16, as a condition of receiving a charity gaming license or nonlicense letter, the following minimum percentage of charitable gaming gross receipts shall be used for those lawful religious, charitable, community, or educational purposes for which the organization is specifically chartered or organized, or those expenses relating to the acquisition, construction, maintenance, or repair of any interest in real property involved in the operation of the organization and used for lawful religious, charitable, community, or educational purposes:

- (1) Five percent (5%) for organizations with annual gross receipts less than one hundred fifty thousand dollars (\$150,000).
- (2) Ten percent (10%) for organizations with annual gross receipts between one hundred fifty thousand dollars (\$150,000) and five hundred thousand dollars (\$500,000).
- (3) Twelve percent (12%) for organizations with annual

gross receipts over five hundred thousand dollars (\$500,000).

Unless an organization has derived no gross receipts in the prior fiscal year, the gross receipts of the most recently completed fiscal year shall be used to determine the applicable percentage for the use of proceeds requirement. An organization with no prior charitable gaming activity shall be subject to a five percent (5.0%) minimum use of proceeds requirement.

(b) If an organization fails to meet the minimum use of proceeds requirement, its license shall be suspended or revoked and no further licensed or unlicensed events may be held.

(c) Except as provided in subsection (b), if an organization is within less than one (1) percentage point of the minimum use of proceeds requirement for a given fiscal year, it may request a one-time approval to make up the deficiency (in dollars) in the following fiscal year. If such approval is granted, the deficiency will be added to the percentage requirement for the following year and the permit shall not be suspended.

(d) Failure to meet the required percentage in the year following such approval shall result in a one (1) year suspension. (*Department of State Revenue; 45 IAC 18-3-7*)

SECTION 46. 45 IAC 18-3-8 IS ADDED TO READ AS FOLLOWS:

**45 IAC 18-3-8 Specific uses of proceeds**

Authority: IC 4-32-7-3  
Affected: IC 4-32

Sec. 8. (a) All payments by a qualified organization as use of proceeds must be made by check written from the organization's charitable gaming account.

(b) Use of proceeds payments may be made for scholarship funds or the future acquisition, construction, remodeling or improvement of real property or the acquisition of other equipment or vehicles to be used for religious, charitable, educational or community purposes. An organization may obtain department approval to establish a special fund account or an irrevocable trust fund for special circumstances. Transfers a special account or an irrevocable trust fund may be included as a use of proceeds if the payment is authorized by an organization's board of directors.

(c) No payments made to a special fund account shall be withdrawn for any purpose other than the specified purpose unless prior notification is made to the department.

(d) Expenditures of charitable gaming funds for social or recreational activities, or for events, activities, or programs

that are open primarily to an organization's members and their families shall not qualify as use of proceeds unless substantial benefit to the community is demonstrated.

(e) Expenditures of charitable gaming funds for salaries or honoraria to officers, directors, members, or employees of the qualified organization shall not qualify as use of proceeds.

(f) Payments made to or on behalf of indigent or sick or deceased members or their immediate families shall be allowed as use of proceeds up to one percent (1%) of an organization's prior year gross receipts provided they are approved by the board of directors and the specific need is documented. Organizations may obtain prior department approval to exceed the one percent (1%) limit in special cases.

(g) Payments made directly for the benefit of an individual member, member of his or her family or person residing in his or her household shall not be allowed as a use of proceeds unless authorized by law.

(h) Use of proceeds payments by an organization shall not be made for any activity that is prohibited by federal, state, or local laws, or for any activity that attempts to influence or finance directly or indirectly political parties or committees or the election or reelection of any person who is or has been a candidate for public office.

(i) Organizations shall provide details of use of proceeds with the annual financial report.

(j) The department may disallow a use of proceeds payment to be counted against the minimum percentage referred to in section 7 of this rule.

(k) If any payment claimed as use of proceeds is subsequently disallowed, an organization may be allowed additional time as specified by the department to meet minimum use of proceeds requirements. (*Department of State Revenue; 45 IAC 18-3-8*)

SECTION 47. 45 IAC 18-4-1 IS AMENDED TO READ AS FOLLOWS:

**45 IAC 18-4-1 Records of qualified organization**

Authority: IC 4-32-7-3  
Affected: IC 4-32

Sec. 1. (a) A qualified organization must maintain adequate records of all financial aspects of a qualified event and report such information to the department on forms prescribed by the department. The organization must set up a separate account to account for all proceeds and expenditures of the qualified event. The records that must be kept include the gross receipts from each type of activity conducted at the allowable event, the prize

## Proposed Rules

pay-out, and the net receipts to the organization. Also, accountable are any rental costs associated with conducting the allowable event, including, but not limited to, a facility lease and the lease of tangible personal property.

(b) The reports are due thirty (30) days after the expiration date listed on the annual bingo license or, in the case of a special event license, ten (10) days after the special event is concluded.

**(c) A qualified organization shall use Schedule CG-NSR (Charity Gaming Nightly Summary Report).**

**(d) The department will be granted unrestricted access to all records, including, but not limited to, the following:**

- (1) Membership information.**
- (2) Financial records.**
- (3) Receipts for the purchase of bingo supplies, punchboards, pull-tabs, and tip boards.**

**(e) An individual, or an employee, officer, or member of a corporate or partnership licensed entity who has a duty to remit gaming card excise tax to the department, holds the tax in trust for the state and is personally liable for the payment of the tax, plus any penalties and interest attributable to the tax.** (*Department of State Revenue; 45 IAC 18-4-1; filed Jan 8, 1993, 9:00 a.m.: 16 IR 1375*)

SECTION 48. 45 IAC 18-4-2 IS AMENDED TO READ AS FOLLOWS:

### **45 IAC 18-4-2 Records of manufacturer or distributor**

Authority: IC 4-32-7-3; IC 4-32-8-3

Affected: IC 4-32-7-4

Sec. 2. (a) An entity licensed as a manufacturer or distributor must keep records satisfactory to the department. The records must include the following:

- (1) Sales invoices, including the following:
  - (A) Each licensee must use a general sales invoice ~~which that~~ is:
    - (i) numbered consecutively; and
    - (ii) prepared in at least two (2) parts, one being issued to the customer and the other retained in an invoice file.
  - (B) Each licensee must use a general sales invoice ~~which that~~ sets out the following information:
    - (i) The date of sale.
    - (ii) The customer name and business address.
    - (iii) A full description of each item sold, including the serial numbers of the products sold.
    - (iv) The quantity and sales price of each item.
    - (v) The manufacturer's or distributor's license number.
    - (vi) The customer's license number.
    - (vii) The gaming card excise tax due on the sale.
- (2) Credit memoranda prepared in the same detail as sales invoices.

(3) A sales journal containing at least the following, by calendar month:

- (A) The date of sale.
  - (B) The invoice number of the sale.
  - (C) The customer name or account number.
  - (D) The total amount of the invoice.
  - (E) The total amount of the gaming card excise tax due on the sale.
- (4) A complete list of the persons representing the licensee.
- (5) Purchase records documenting that all bingo supplies, equipment, pull-tabs, punchboards, and tip boards were purchased from either a licensed manufacturer or another licensed distributor.

(b) A serial number printed on an item sold must be identifiable with the sales invoice reflecting the sale of the specific item.

~~(c)~~ The gross amount of sales to each customer must be kept on a calendar month basis:

~~(d)~~ (c) Records are required to be maintained until the later of the following:

- (1) ~~Four (4)~~ Six (6) years after the year in which they are created.
- (2) The end of the audit if such records are under audit.
- (3) Marketing sheets that show the expected gross income, payout, net income, and number of deals in the pull-tab game, which have been sold to the qualified organization. The term "payout" does not include the cost of the game itself.**

**(d) If a licensed manufacturer or distributor destroys, discontinues, or otherwise tenders unusable, bingo supplies, punchboards, pull-tabs, or tip boards, then the manufacturer or distributor must provide the department with a written list of the items destroyed, including quantity, description of the items and serial numbers, and the date on which the items were destroyed.**

**(e) A licensed manufacturer or distributor must keep the department informed of its location and where the records will be stored if the manufacturer ceases business.**

**(f) The foregoing records must be produced upon request by the department or its representative.**

**(g) Manufacturers or distributors of supplies, devices, or equipment, as described in IC 4-32-7-4(a) to be used in charity gaming in Indiana, must submit monthly reports, as prescribed by the department, detailing their sales of punchboards, pull-tabs, and tip boards to Indiana not-for-profit organizations.** (*Department of State Revenue; 45 IAC 18-4-2; filed Jan 8, 1993, 9:00 a.m.: 16 IR 1375*)

SECTION 49. 45 IAC 18-5-2 IS AMENDED TO READ AS FOLLOWS:

**45 IAC 18-5-2 Gaming card excise tax**

Authority: IC 4-32-7-3; IC 4-32-8-3  
 Affected: IC 4-32-15

Sec. 2. (a) An excise tax is imposed on ~~the distribution of pull-tabs, punchboards, and tip boards~~ **a licensed distributor or manufacturer** in the amount of ten percent (10%) of the ~~wholesale price for the paid by the qualified organization that purchases pull-tabs, punchboards, or tip boards. that are sold to a qualified organization. The tax is effective June 1, 1992, for all sales that occur after May 31, 1992.~~

(b) Sales of bingo supplies and bingo equipment by manufacturers or distributors are not subject to the gaming card excise tax.

(c) A licensed entity supplying ~~pull-tabs, punchboards, or tip boards~~ is liable for the tax. ~~The tax is imposed at the time the licensed entity:~~

- (1) ~~brings or causes the pull-tabs, punchboards, or tip boards to be brought into Indiana for distribution;~~
- (2) ~~manufactures pull-tabs, punchboards, or tip boards in Indiana for distribution; or~~
- (3) ~~transports pull-tabs, punchboards, or tip boards to qualified organizations in Indiana for resale by those qualified organizations.~~

(d) (c) The gaming card excise tax is due twenty (20) days after the end of the calendar month in which the tax is imposed. It shall be remitted with the forms prescribed by the department.

(e) (d) All payments must be in the form of a check, a draft, or another financial instrument approved by the department prior to payment.

(f) (e) The department may, at any time, perform an audit of the books of a licensed entity to ensure compliance with IC 4-32-15. (*Department of State Revenue; 45 IAC 18-5-2; filed Jan 8, 1993, 9:00 a.m.: 16 IR 1376*)

SECTION 50. 45 IAC 18-6-3 IS AMENDED TO READ AS FOLLOWS:

**45 IAC 18-6-3 License revocation**

Authority: IC 4-32-7-3; IC 4-32-8-3  
 Affected: IC 4-32; IC 6-8.1

Sec. 3. (a) The proposed action of the department to impose a civil penalty under this article is subject to review under IC 6-8.1. However, the licensee has only seventy-two (72) hours from its receipt of the decision, intended decision, or other action to file a written protest. Except as provided in subsection (b), as long as the matter is under protest, the licensee can continue to operate until all administrative appeals have been exhausted.

(b) The department may determine at any time that an emergency exists that requires the immediate ~~termination~~

of a license. Effective with the receipt of the department's decision to ~~terminate~~ **revoke** its license, a licensee must cease all operations that were previously authorized under the license.

(c) An emergency requiring the immediate ~~termination~~ **revocation** of a license will be deemed to exist under any of the following circumstances:

- (1) The information provided on the application for license is found to be false or misleading.
- (2) The appropriate fees are not paid.
- (3) An entity other than the qualified organization is conducting the allowable event.
- (4) The qualified organization is exceeding its allowable expenditures with respect to an allowable event.
- (5) The qualified organization is exceeding the number of days that it can conduct an allowable event.
- (6) The organization has conducted an allowable event at the same place and on the same day as another qualified organization.
- (7) Net proceeds are being used for purposes other than the lawful purposes of the organization.
- (8) Accurate reports are not being filed with the department in a timely manner.
- (9) Receipts and expenditures from an allowable event are not being kept in a separate and segregated account set up for that purpose.
- (10) An allowable event is being held in a county other than where the qualified organization's principal office is located.
- (11) An operator or worker does not meet the requirements of IC 4-32.
- (12) Prizes awarded are exceeding the limitations imposed by IC 4-32.
- (13) **Fails or refuses to comply with the record keeping requirement of IC 4-32.**
- (14) **Fails or refuses to allow inspection of records kept under IC 4-32.**
- (15) Any other violation of IC 4-32 or this article considered to be of a serious nature by the department.

(d) If a licensee does not file a formal protest of the department's proposed termination of its license within the time limit imposed by subsection (a), then such inaction may be deemed an admission of the alleged violation and the department may issue an immediate termination of the license.

(e) The license of a manufacturer or distributor shall be terminated if there is a change in ownership and the department determines that an undesirable party is assuming the privileges of the license held by the manufacturer or distributor. (*Department of State Revenue; 45 IAC 18-6-3; filed Jan 8, 1993, 9:00 a.m.: 16 IR 1376*)

SECTION 51. 45 IAC 18-7 IS ADDED TO READ AS FOLLOWS:

## Proposed Rules

### Rule 7. Violations

#### 45 IAC 18-7-1 Violations

Authority: IC 4-32-7-3; IC 4-32-8-3

Affected: IC 4-32-7-4; IC 4-32-9; IC 6-8.1

Sec. 1. (a) A qualified organization shall not enter into any formal or informal agreement, including, but not limited to, hiring, contracting, and the lease of real or tangible personal property, with a person who is affiliated with that organization. Such affiliations include, but are not limited to, members, officers, directors, or their family members.

(b) A manufacturer, distributor, or their officers, employees, or agents shall not affiliate with the gaming operation of a qualified organization in any manner other than the sale or lease of gaming supplies

(c) Licensed entities under IC 4-32-7-4 shall not sell gaming supplies or equipment to any person or organization not licensed as a distributor or qualified organization.

(d) An applicant for a charity gaming license may not use a post office box instead of an actual street address on any part of its application. This shall include the requirement of operator and worker addresses.

(e) Any holder of an Indiana charity gaming license, a distributor's license, or a manufacturer's license shall not prohibit the department's employees from entering the licensed premises for inspection of all books and records.

(f) If an organization makes an application for a charity gaming license, and, after investigation by the department, the application is denied because the organization has violated:

- (1) IC 4-32-9-15;
- (2) IC 4-32-9-23;
- (3) IC 4-32-9-25;
- (4) IC 4-32-9-26;
- (5) IC 4-32-9-28; or
- (6) IC 4-32-9-29;

the organization may not reapply for any charity gaming license for a period of one (1) year, after the date of the denial by the department or the exhaustion of administrative remedies, or resulting legal action whichever is later in time. (*Department of State Revenue; 45 IAC 18-7-1*)

SECTION 52. 45 IAC 18-8 IS ADDED TO READ AS FOLLOWS:

### Rule 8. Administrative Procedures

#### 45 IAC 18-8-1 Representation of a qualified organization before the department

Authority: IC 4-32-7-3; IC 4-32-8-3

Affected: IC 4-32

Sec. 1. (a) There are no formal qualifications for individuals to represent a qualified organization before the department. Prior to the department releasing any information to any person representing a qualified organization or licensee, or otherwise appearing or communicating with the department on a qualified organization or licensee's behalf, the representative must present a properly executed power of attorney, or, if the person is an attorney at law, then an appearance must be filed. No information will be released to anyone other than an officer or director of the qualified organization, unless a properly executed power of attorney or appearance has been presented. Power of attorney and appearance forms are available from the department.

(b) Casual conversations with a qualified organization or licensee's representative who does not have an appearance on file are permitted. However, specific information will not be disclosed.

(c) The appearance must contain the following information:

- (1) The name, address, and taxpayer identification number of the qualified organization.
- (2) The name, address, and telephone number of the qualified organization's representative or representatives. A corporation, law firm, or accounting firm must name at least one (1) individual as the representative.
- (3) Any restrictions or limitations placed upon the representative when acting on behalf of the qualified organization.
- (4) The appearance must be signed by an officer of the qualified organization, or an individual authorized to execute a power of attorney. The department may require that the signature be notarized by a notary public if the representative is not a licensed attorney or certified public accountant.

(d) If the qualified organization executes an appearance, the department will communicate primarily with the organization's representative. (*Department of State Revenue; 45 IAC 18-8-1*)

#### 45 IAC 18-8-2 Notice

Authority: IC 4-32-7-3; IC 4-32-8-3

Affected: IC 4-32

Sec. 2. If the department believes that a qualified organization or licensee has improperly reported a listed tax liability, the department may, within the prescribed statute of limitations period, issue to such qualified organization or licensee a formal notice that the department proposes to assess additional tax. The formal notice shall be based on the best information available to the department. Any written advisement, which informs the qualified organization or licensee of the amount of the proposed assessment for a particular tax period, shall constitute a formal notice.



A formal notice shall be sent through the United States mail. (*Department of State Revenue; 45 IAC 18-8-2*)

#### **45 IAC 18-8-3 Protests**

Authority: IC 4-32-7-3; IC 4-32-8-3  
Affected: IC 4-32

Sec. 3. (a) An entity has seventy-two (72) hours, as calculated in section 9 of this rule, from the date the notice of violation or department order is received to protest the department's findings under IC 4-32. The calculation of the seventy-two (72) hours begins at 8 a.m. the day following the receipt of the department's notice.

(b) All protests must be in writing and include the organization's name, taxpayer identification number, address, and the basis for objections to the department's findings.

(c) If the organization desires a hearing before the department, the protest shall so state. If an application or reapplication has been denied, the organization may, instead of a hearing, refile its application or pay the civil fines. Protests should be submitted to the charity gaming hearing officer.

(d) The department may correspond with the entity before the hearing, either in writing or orally, in order to gather information and clarify issues presented in the protest letter. (*Department of State Revenue; 45 IAC 18-8-3*)

#### **45 IAC 18-8-4 Hearings**

Authority: IC 4-32-7-3; IC 4-32-8-3  
Affected: IC 4-32

Sec. 4. (a) A qualified organization receiving a notice from the department shall have a right to protest and have a hearing of the facts and issues before the department makes a final determination.

(b) The department's hearing procedures are as follows:

(1) Upon receipt of a timely protest requesting a hearing with the department, the organization's protest will be forwarded to the charity gaming hearing officer.

(2) The charity gaming hearing officer shall set a date for a hearing of the protest and the qualified organization will be notified of the time and place thereof.

(3) Once a hearing date has been set, extensions of time, continuances, and adjournments may be granted at the discretion of the department upon a showing of good cause.

(4) If the qualified organization or its duly authorized representative wishes to file legal memoranda with the department concerning the facts, issues and arguments of its protest, that material must be submitted at least five (5) days prior to the date of the hearing.

(5) If an organization or its representative fails to appear at a hearing without securing a continuance, a default

judgment will be issued in favor of the department.

(6) The hearing will be conducted in an informal manner. The purpose of the hearing is to establish the qualified organization's specific objections and the reason for those objections.

(7) The burden of proving that the department's findings are incorrect rests with the organization against which the department's findings are made. The department's investigation establishes a prima facie presumption of the validity of the department's findings.

(8) If an organization fails to appear for a scheduled hearing, the petitioner will be assessed the costs of holding the hearing in their absence. An organization will no longer be in good standing with the department if they fail to pay the costs of conducting the hearing within thirty (30) days.

(*Department of State Revenue; 45 IAC 18-8-4*)

#### **45 IAC 18-8-5 Department's findings**

Authority: IC 4-32-7-3; IC 4-32-8-3  
Affected: IC 4-32

Sec. 5. The protest will not be resolved at the hearing. The department will consider all facts and arguments presented and a decision will be rendered in writing described as a departmental order. (*Department of State Revenue; 45 IAC 18-8-5*)

#### **45 IAC 18-8-6 Rehearing**

Authority: IC 4-32-7-3; IC 4-32-8-3  
Affected: IC 4-32

Sec. 6. (a) After receipt of the departmental order, the taxpayer may petition for a rehearing. The petition for rehearing must be timely filed according to section 3 of this rule. A rehearing will be granted by the department only under unusual circumstances. The taxpayer must allege that certain material facts or circumstances were not presented or considered in the original proceedings. A rehearing is granted at the discretion of the department.

(b) If a rehearing is granted, the rehearing will not be held de novo unless abuse of discretion is alleged. When such abuse is alleged, the evidence will not be reweighed. Instead, the department will only consider evidence most favorable to the department's position and reverse only if the decision is clearly against the logic and effect of the facts and circumstances. However, if the taxpayer presents new and relevant evidence as grounds for reversal, the new evidence will be weighed in light of all relevant facts and circumstances. (*Department of State Revenue; 45 IAC 18-8-6*)

#### **45 IAC 18-8-7 Statute of limitations and retention of records**

Authority: IC 4-32-7-3; IC 4-32-8-3  
Affected: IC 4-32; IC 6-8.1-5-2

Sec. 7. Except as otherwise provided in IC 6-8.1-5-2, the

---

---

## Proposed Rules

---

---

statute of limitations for the assessment of a listed tax is governed by 45 IAC 15-5-7. There is no statute of limitations imposed upon the department investigating a violation of IC 4-32. A qualified organization must retain its business records in accordance with the following schedule:

- (1) The following must be retained for ten (10) years:
  - (A) IT-35AR.
  - (B) ST-103.
  - (C) Nightly game sheets.
  - (D) Federal Form 990.
- (2) The following must be retained for three (3) years:
  - (A) Seal cards.
  - (B) Flare cards.
  - (C) Schedule CG-NSR.
  - (D) All other documents kept in the regular course of conducting charity gaming events.

*(Department of State Revenue; 45 IAC 18-8-7)*

### 45 IAC 18-8-8 Holidays

Authority: IC 4-32-7-3; IC 4-32-8-3  
Affected: IC 1-1-9-1; IC 4-32

Sec. 8. Any act that is required to be performed under IC 4-32 may be performed on the succeeding business day if the due date falls on any state holiday listed in IC 1-1-9-1, any other national legal holiday, or a Saturday or Sunday.  
*(Department of State Revenue; 45 IAC 18-8-8)*

### 45 IAC 18-8-9 Date of filing

Authority: IC 4-32-7-3; IC 4-32-8-3  
Affected: IC 4-32

Sec. 9. (a) If a document, which is required to be filed with the department by a prescribed date, is mailed through the United States mail, the date displayed on the post office cancellation mark establishes an irrebuttable presumption that the displayed date was the date on which the document was filed. If a document is delivered to the department in any other manner than the United States mail, the department shall stamp the document in such a fashion as to display the date the document is received. This date stamped by the department shall establish an irrebuttable presumption as to the date the document is received.

(b) If a document is sent through the United States mail by registered mail, certified mail, or certificate of mailing, then such date of registration, certification, or certificate shall be conclusive as to the date of filing. Such date as authenticated by the United States post office records shall be conclusive even in the case of a conflicting postmark date.

(c) If a document mailed through the United States mail is physically received after the due date without a legibly correct postmark, the person who mailed the document may show the document was mailed on or before the due

date by reasonable evidence. Examples of such evidence include, but are not limited to, the following:

- (1) Testimony of the party.
- (2) Testimony of disinterested third parties.
- (3) Evidence and/or testimony from the United States post office.
- (4) Any other evidence which tends to establish the date of filing.

(d) If a document is mailed to, but never received by the department, the person sending the document may produce reasonable evidence to show that the document was mailed on or before the due date. Such evidence as used to show the correct postmark date in 45 IAC 14-6-3(c) *[sic.]* might also be used to establish the mailing of a document. In addition to showing that the document was deposited in the United States mail on or before the due date, the person must file a duplicate document with the department within thirty (30) days from the date the department sends the person notice that the prescribed documents were not received. *(Department of State Revenue; 45 IAC 18-8-9)*

SECTION 53. THE FOLLOWING ARE REPEALED: 45 IAC 18-1-2; 45 IAC 18-1-3; 45 IAC 18-1-4; 45 IAC 18-1-5; 45 IAC 18-1-6; 45 IAC 18-1-7; 45 IAC 18-1-8; 45 IAC 18-3-3; 45 IAC 18-6-1; 45 IAC 18-6-2.

### Notice of Public Hearing

*Under IC 4-22-2-24, notice is hereby given that on July 22, 2002 at 10:00 a.m., at the Indiana Government Center-South, 402 West Washington Street, Conference Center Room B, Indianapolis, Indiana the Department of State Revenue will hold a public hearing on proposed rules to amend and clarify the rules concerning charity gaming conducted by qualified organizations. Copies of these rules are now on file at the Indiana Government Center-North, 100 North Senate Avenue, Room 248 and Legislative Services Agency, One North Capitol, Suite 325, Indianapolis, Indiana and are open for public inspection.*

Kenneth L. Miller  
Commissioner  
Department of State Revenue

---

---

## TITLE 312 NATURAL RESOURCES COMMISSION

Proposed Rule  
LSA Document #01-293

### DIGEST

Amends 312 IAC 5-6-6 that provides restricted watercraft zones on Lake Wawasee to replace 10 mile per hour speed limits with expanded idle speed zones and watercraft prohibi-

tion zones on Lake Wawasee and Syracuse Lake for the protection of ecological resources. Effective 30 days after filing with the secretary of state.

**312 IAC 5-6-6**

SECTION 1. 312 IAC 5-6-6 IS AMENDED TO READ AS FOLLOWS:

**312 IAC 5-6-6 Lake Wawasee and Syracuse Lake; special watercraft zones**

Authority: IC 14-10-2-4; IC 14-15-7-3  
Affected: IC 14

Sec. 6. (a) This section establishes restrictions on the operation of watercraft on and between Lake Wawasee and Syracuse Lake in Kosciusko County. The coordinates used in this section are on the Indiana coordinate system of 1983, east zone, in United States Survey feet as defined in IC 32-19-1-1, hereinafter referred to as SPC.

(b) A person must not operate a watercraft in excess of ten (10) miles per hour on Lake Wawasee within an area described as follows: idle speed in any of the following locations:

(1) North and west of Pickwick Road In an area known as Johnson Bay on Lake Wawasee, and more particularly described as east and north of buoys placed along a boundary in the northeastern portion of the bay. The boundary:

(A) begins at its southernmost point with a buoy placed at SPC 2244173.23 north and SPC 323786.03 east;

(B) continues in a northwesterly direction, including, but not limited to, buoys placed at:

(i) SPC 2244348.87 north and SPC 323439.20 east;

(ii) SPC 2244959.54 north and SPC 323331.64 east; and

(iii) SPC 2245188.84 north and SPC 322952.76 east; and

(C) concludes with the northernmost buoy placed at SPC 2245460.99 north and SPC 322442.69 east.

(2) South of the CSX railroad In an area known as Johnson Bay on Lake Wawasee, and more particularly described as west of buoys forming a boundary in the western portion of the bay. The boundary:

(A) begins at its southernmost point with a buoy placed at SPC 2242916.32 north and SPC 321786.06 east;

(B) continues north, including, but not limited to, buoys placed at:

(i) SPC 2243201.20 north and SPC 321889.40 east; and

(ii) SPC 2243594.17 north and SPC 321842.69 east; and

(C) concludes with the northernmost buoy placed at SPC 2243903.36 north and SPC 321985.50 east.

(3) East of the Furtle Bay housing development In the area known as Conklin Bay on Lake Wawasee, and more particularly described as west and south of buoys forming a boundary in the southwestern portion of the bay entrance. The boundary:

(A) begins at its easternmost point with a buoy placed

at SPC 2242757.49 north and SPC 310031.71 east;

(B) continues in a northwesterly direction along buoys placed at points, including, but not limited to:

(i) SPC 2242767.16 north and SPC 309590.62 east;

(ii) SPC 2242759.48 north and SPC 309502.02 east;

(iii) SPC 2243000.96 north and SPC 309262.89 east;

(iv) SPC 2243007.82 north and SPC 309161.84 east;

(v) SPC 2243121.70 north and SPC 308708.60 east; and

(vi) SPC 2243143.59 north and SPC 308440.77 east; and

(C) concludes at its northernmost point with a buoy placed at SPC 2243332.11 north and SPC 308363.57 east.

(4) In the area of Lake Wawasee, commonly referred to as the channel area and Mud Lake, that lies between the main body of Lake Wawasee and Syracuse Lake.

(5) In the southeastern portion of Syracuse Lake, more particularly described as east and south of buoys forming a boundary that:

(A) begins at its northernmost point with a buoy placed at SPC 2249799.53 north and SPC 311364.04 east;

(B) continues in a southwesterly direction to include buoys placed at:

(i) SPC 2249436.77 north and SPC 310315.97 east; and

(ii) SPC 2249156.14 north and SPC 310047.98 east; and

(C) concludes at its southernmost point with a buoy placed at SPC 2248558.17 north and SPC 309952.51 east.

(6) In an area commonly referred to as the north bay on Lake Wawasee, more particularly described as north of the boundary between buoys placed at:

(A) SPC 2246336.50 north and SPC 313670.41 east; and

(B) SPC 2246294.91 north and SPC 312868.18 east.

(c) In addition to subsection (b)(6), a person must not operate, anchor, or moor a watercraft in either of the following restricted zones located in the area commonly referred to as the north bay on Lake Wawasee:

(1) Within the rectangular shaped area bounded by buoys designating the:

(A) southwestern corner of the area at SPC 2246372.00 north and SPC 313226.16 east;

(B) northwestern corner at SPC 2246561.00 north and SPC 313224.59 east;

(C) northeastern corner at SPC 2246576.75 north and SPC 313538.09 east; and

(D) southeastern corner at SPC 2246382.25 north and SPC 313549.53 east.

(2) Within the rectangular shaped area bounded by buoys designating the southwestern corner of the:

(A) area at SPC 2246371.25 north and SPC 312958.88 east;

(B) northwestern corner at SPC 2246558.25 north and SPC 312954.19 east;

(C) northeastern corner at SPC 2246558.50 north and SPC 313090.28 east; and

## Proposed Rules

### **(D) southeastern corner at 2246374.50 north and SPC 313091.94 east.**

*(Natural Resources Commission; 312 IAC 5-6-6; filed Mar 23, 2001, 2:50 p.m.: 24 IR 2374, eff Jan 1, 2002)*

#### **Notice of Public Hearing**

*Under IC 4-22-2-24, notice is hereby given that on August 5, 2002 at 6:00 p.m., at the Upper Level Academy Center, Oak Inn and Conference Center, 702 East Lake View Road, Syracuse, Indiana the Natural Resources Commission will hold a public hearing on proposed amendments that provide restricted watercraft zones on Lake Wawasee to replace 10 mile per hour speed limits with expanded idle speed zones and watercraft prohibition zones on Lake Wawasee and Syracuse Lake for the protection of ecological resources. Copies of these rules are now on file at the Indiana Government Center-South, 402 West Washington Street, Room W272 and Legislative Services Agency, One North Capitol, Suite 325, Indianapolis, Indiana and are open for public inspection.*

Michael Kiley  
Chairman  
Natural Resources Commission

### **TITLE 326 AIR POLLUTION CONTROL BOARD**

#### **Proposed Rule**

LSA Document #02-88

#### **DIGEST**

Amends 326 IAC 1-4-1; 326 IAC 4-1-4.1; 326 IAC 8-2-9; and 326 IAC 13-3-1 concerning the redesignation of Clark and Floyd Counties to attainment of the one hour ozone standard. Effective 30 days after filing with the secretary of state.

#### **HISTORY**

Second Notice of Comment Period and Section 7 Notice of First Hearing: April 1, 2002, Indiana Register (25 IR 2315).

Date of First Hearing: June 5, 2002.

#### **PUBLIC COMMENTS UNDER IC 13-14-9-4.5**

IC 13-14-9-4.5 states that a board may not adopt a rule under IC 13-14-9 that is substantively different from the draft rule published under IC 13-14-9-4, until the board has conducted a third comment period that is at least twenty-one (21) days long. Because this proposed rule is not substantively different from the draft rule published on April 1, 2002, at 25 IR 2315, the Indiana Department of Environmental Management (IDEM) is not requesting additional comment on this proposed rule.

#### **SUMMARY/RESPONSE TO COMMENTS FROM THE SECOND COMMENT PERIOD**

IDEM requested public comment from April 1, 2002, through May 1,

2002, on IDEM's draft rule language. No comments were received during the second comment period.

#### **SUMMARY/RESPONSE TO COMMENTS RECEIVED AT THE FIRST PUBLIC HEARING**

On June 5, 2002, the air pollution control board (board) conducted the first public hearing/board meeting concerning the development of amendments to 326 IAC 1-4-1; 326 IAC 4-1-4.1; 326 IAC 8-2-9; and 326 IAC 13-3-1. No comments were made at the first hearing.

**326 IAC 1-4-1**

**326 IAC 4-1-4.1**

**326 IAC 8-2-9**

**326 IAC 13-3-1**

SECTION 1. 326 IAC 1-4-1, AS AMENDED AT 25 IR 3056, SECTION 6, IS AMENDED TO READ AS FOLLOWS:

#### **326 IAC 1-4-1 Designations**

**Authority:** IC 13-14-8; IC 13-17-3-4; IC 13-17-3-11

**Affected:** IC 13-15; IC 13-17

Sec. 1. The air pollution control board incorporates by reference 40 CFR 81.315\* and **66 FR 53665 (October 23, 2001)\*** concerning attainment status designations.

\*This document is \*These documents are incorporated by reference. Copies may be obtained from the Government Printing Office, 732 North Capitol Street NW, Washington, D.C. 20401 or are available for review and copying at the Indiana Department of Environmental Management, Office of Air Quality, Indiana Government Center-North, Tenth Floor, 100 North Senate Avenue, Indianapolis, Indiana 46204. *(Air Pollution Control Board; 326 IAC 1-4-1; filed Mar 10, 1988, 1:20 p.m.: 11 IR 2379; filed Aug 9, 1991, 11:00 a.m.: 14 IR 2218; filed Dec 30, 1992, 9:00 a.m.: 16 IR 1382; filed Apr 18, 1995, 3:00 p.m.: 18 IR 2220; filed Oct 22, 1997, 8:45 a.m.: 21 IR 932; filed Apr 17, 1998, 9:00 a.m.: 21 IR 3342; filed Apr 29, 1998, 3:15 p.m.: 21 IR 3341; filed May 21, 2002, 10:20 a.m.: 25 IR 3056)*

SECTION 2. 326 IAC 4-1-4.1 IS AMENDED TO READ AS FOLLOWS:

#### **326 IAC 4-1-4.1 Open burning approval; criteria and conditions**

**Authority:** IC 13-15-2-1; IC 13-17-3-4

**Affected:** IC 4-21.5; IC 13-12; IC 13-17-9

Sec. 4.1. (a) Burning not exempted by section 3 or 4 of this rule may be authorized by the issuance of an approval by the commissioner or the commissioner's designated agent after consideration of an approval application. Such burning may be authorized for, but not limited to, the following:

(1) Burning for the purpose of fire training.

(2) Burning of natural growth derived from a clearing operation, such as removal of natural growth for change in use of the land.

(3) Burning of highly explosive or other dangerous materials

for which no alternative disposal method exists or where transportation of such materials is hazardous.

- (4) Burning of clean wood products.
- (5) Burning of natural growth for the purpose of land management.

(b) The following criteria may be considered for approval under this section:

- (1) The applicant has demonstrated that alternative methods for disposal are impractical or prohibitively expensive.
- (2) There are not more than five (5) residences or structures within five hundred (500) feet of the proposed burning site.
- (3) There have been no open burning violations at the site of the proposed burning or by the applicant.
- (4) If the application involves a structure for fire training, the structure has not been demolished prior to training activities.
- (5) The burning site is located in a county not designated as a nonattainment area for PM<sub>10</sub> or ozone **and is not located in Clark or Floyd County**. The commissioner or the commissioner's agent may allow open burning in ~~such nonattainment~~ **these** areas, subject to conditions necessary to protect air quality.

(c) No approval shall be granted at any time for residential burning in Clark, Floyd, Lake, or Porter County.

(d) Any approval shall be subject to the following conditions unless otherwise stipulated in the open burning approval letter:

- (1) Only clean wood products shall be burned.
- (2) No asbestos-containing material shall be burned.
- (3) No burning shall be conducted during unfavorable meteorological conditions, such as:
  - (A) high winds, temperature inversions, or air stagnation; or
  - (B) when a pollution alert or ozone action day has been declared.
- (4) Burning shall be conducted during daylight hours only and all fires shall be extinguished prior to sunset.
- (5) If at any time the fire creates:
  - (A) an air pollution problem;
  - (B) a threat to public health;
  - (C) a nuisance; or
  - (D) a fire hazard;

the burning shall be extinguished.

- (6) The local fire department and health department must be notified at least twenty-four (24) hours in advance of the date, time, and location of the burning.
- (7) The approval letter shall be made available at the burning site to state and local officials upon request except during emergency burning.
- (8) Adequate fire fighting equipment shall be on-site for extinguishing purposes during burning times.
- (9) No burning shall take place within:
  - (A) one hundred (100) feet of any structure or powerline; or
  - (B) three hundred (300) feet of a frequently traveled road, fuel storage area, or pipeline.

(10) Fires must be attended at all times until completely extinguished.

- (11) All burning must comply with other federal, state, or local laws, regulations, or ordinances, including 40 CFR 61 Subpart M\* (National Emissions Standards for Asbestos).
- (12) No waste that is regularly generated as a result of a routine business operation shall be burned.
- (13) The material to be burned shall not exceed one thousand (1,000) cubic feet.

(e) An approval letter shall be valid for no longer than one (1) year from the date of issuance. However, an approval letter may be valid for as long as five (5) years if the approval application is accompanied by an open burning plan. The plan shall:

- (1) contain a description of the open burning proposed for the period of time for which an approval letter is sought; and
- (2) be incorporated as a condition of the approval letter under subsection (d) or (f).

Any change in the plan must receive an additional approval letter, unless the change is to reduce open burning, or the change is to conduct burning exempted under section 3 of this rule. The plan shall be available for review upon the request by the department.

(f) The commissioner or the commissioner's designated agent may add conditions to an approval letter, as necessary, to prevent a public nuisance or protect the public health or the environment. Such conditions may be based on local air quality conditions, including whether the area is a nonattainment county as defined in 326 IAC 1-4-1 or has been redesignated from nonattainment to attainment status.

(g) A decision on the open burning approval letter is subject to IC 4-21.5 (Administrative Orders and Procedures Act).

**\*This document is incorporated by reference. Copies may be obtained from the Government Printing Office, 732 North Capitol Street NW, Washington, D.C. 20401 or are available for review and copying at the Indiana Department of Environmental Management, Office of Air Quality, Indiana Government Center-North, Tenth Floor, 100 North Senate Avenue, Indianapolis, Indiana 46204. (Air Pollution Control Board; 326 IAC 4-1-4.1; filed Jul 30, 1996, 2:00 p.m.: 19 IR 3343; readopted filed Jan 10, 2001, 3:20 p.m.: 24 IR 1477)**

SECTION 3. 326 IAC 8-2-9 IS AMENDED TO READ AS FOLLOWS:

**326 IAC 8-2-9 Miscellaneous metal coating operations**

**Authority:** IC 13-14-8; IC 13-17-3-4; IC 13-17-3-11  
**Affected:** IC 13-15; IC 13-17

Sec. 9. (a) This section is applicable to the surface coating of the following:

- (1) Large and small farm machinery.
- (2) Small household appliances.

## Proposed Rules

- (3) Office equipment.
- (4) Industrial machinery.
- (5) Any other industrial category which coats metal parts or products under the Standard Industrial Classification Code of major groups #33, #34, #35, #36, #37, #38, and #39.

(b) This section is not applicable to the surface coating of the following metal parts and products or to the following types of coating except as indicated in subsection (c):

- (1) Any metal parts or products limited by other sections of this rule.
- (2) Exterior of airplanes.
- (3) Automobile refinishing.
- (4) Customized top coating of automobiles and trucks, if production is less than thirty-five (35) vehicles per day.
- (5) Exterior of marine vessels.
- (6) Maintenance coatings of production equipment.
- (7) The application of adhesives or preparation of adhesives.
- (8) Lubricants used to prevent sticking of internally moving parts.
- (9) Chromium plated plastics.
- (10) The application of coatings to burial caskets (Standard Industrial Classification Code 3995) if the source is not located in or adjacent to a county designated as nonattainment for ozone **or if the source is not located in or adjacent to Clark or Floyd County.**

(c) Commencing July 1, 1991, the operations described in subsection (b)(6) through (b)(9) shall comply with the requirements of this section.

(d) No owner or operator of a facility engaged in the surface coating of miscellaneous metal parts and products may cause, allow, or permit the discharge into the atmosphere of any volatile organic compounds in excess of the following:

- (1) Fifty-two hundredths (0.52) ~~kilograms~~ **kilogram** per liter (four and three-tenths (4.3) pounds per gallon) of coating, excluding water, delivered to a coating applicator that applies clear coatings. A clear coating is a coating that lacks color or opacity and is transparent and uses the undercoat as a reflectant base or undertone color.
- (2) Forty-two hundredths (0.42) ~~kilograms~~ **kilogram** per liter (three and five-tenths (3.5) pounds per gallon) of coating excluding water, delivered to a coating applicator in a coating application system that is air dried or forced warm air dried at temperatures up to ninety (90) degrees Celsius (~~90°C~~) (one hundred ninety-four (194) degrees Fahrenheit. (~~194°F~~)).
- (3) Forty-two hundredths (0.42) ~~kilograms~~ **kilogram** per liter (three and five-tenths (3.5) pounds per gallon) of coating, excluding water, delivered to a coating applicator that applies extreme performance coatings. Extreme performance coatings are coatings designed for exposure to temperatures consistently above ninety-five (95) degrees Celsius, (~~95°C~~); detergents, abrasive or scouring agents, solvents, corrosive atmospheres, outdoor weather at all times, or similar environmental conditions.

(4) Thirty-six hundredths (0.36) ~~kilograms~~ **kilogram** per liter (three (3) pounds per gallon) of coating, excluding water, delivered to a coating applicator for all other coatings and coating application systems.

(e) If more than one (1) emission limitation in subsection (d) applies to a specific coating, then the least stringent emission limitation shall be applied.

(f) Solvent sprayed from application equipment during cleanup or color changes shall be directed into containers. Such containers shall be closed as soon as such solvent spraying is complete, and the waste solvent shall be disposed of in such a manner that evaporation is minimized. (*Air Pollution Control Board; 326 IAC 8-2-9; filed Feb 9, 1988, 2:07 p.m.: 11 IR 1736; filed Mar 10, 1988, 1:20 p.m.: 11 IR 2534; filed Apr 18, 1990, 4:55 p.m.: 13 IR 1678; readopted filed Jan 10, 2001, 3:20 p.m.: 24 IR 1477*)

SECTION 4. 326 IAC 13-3-1 IS AMENDED TO READ AS FOLLOWS:

### 326 IAC 13-3-1 Applicability

Authority: IC 13-14-8; IC 13-17-3-4; IC 13-17-3-11  
Affected: IC 13-15; IC 13-17

Sec. 1. (a) This rule applies to:

- (1) all refiners, importers, carriers, or terminals who supply gasoline for use in the Clark and Floyd Counties ~~ozone nonattainment area~~ between May 1 and September 15 of each calendar year beginning in 1995; and
- (2) all retail stations and other end users who sell or dispense gasoline in Clark or Floyd ~~Counties~~ **County** between June 1 and September 15 of each calendar year beginning in 1995.

(b) If federal reformulated gas (RFG) is required by operation of federal law to be sold in Clark and Floyd Counties or if the governor elects to participate in the RFG program, this rule shall no longer apply after the date that RFG is required to be sold. The department shall make all reasonable efforts to notify the affected parties listed in this section no later than thirty (30) days after federal law requires RFG to be sold or the governor's election to participate in the RFG program. (*Air Pollution Control Board; 326 IAC 13-3-1; filed Jul 6, 1995, 11:30 a.m.: 18 IR 2738; readopted filed Jan 10, 2001, 3:20 p.m.: 24 IR 1477*)

### Notice of Public Hearing

*Under IC 4-22-2-24, IC 13-14-8-6, and IC 13-14-9, notice is hereby given that on August 7, 2002 at 1:00 p.m., at the Indiana Government Center-South, 402 West Washington Street, Conference Center Room C, Indianapolis, Indiana the Air Pollution Control Board will hold a public hearing on proposed amendments to 326 IAC 1-4-1, 326 IAC 4-1-4.1, 326 IAC 8-2-9, and 326 IAC 13-3-1.*

*The purpose of this hearing is to receive comments from the public prior to final adoption of these rules by the board. All interested persons are invited and will be given reasonable opportunity to express their views concerning the proposed amendments. Oral statements will be heard, but for the accuracy of the record, all comments should be submitted in writing.*

*Additional information regarding this action may be obtained from Chrystal Wagner, Rules Development, Office of Air Quality, (317) 234-1203 or (800) 451-6027 (in Indiana).*

*Individuals requiring reasonable accommodations for participation in this event should contact the Indiana Department of Environmental Management, Americans with Disabilities Act coordinator at:*

*Attn: ADA Coordinator*

*Indiana Department of Environmental Management*

*100 North Senate Avenue*

*P.O. Box 6015*

*Indianapolis, Indiana 46206-6015*

*or call (317) 233-0855. (TDD): (317) 232-6565. Speech and hearing impaired callers may contact IDEM via the Indiana Relay Service at 1-800-743-3333. Please provide a minimum of 72 hours' notification.*

*Copies of these rules are now on file at the Indiana Government Center-North, 100 North Senate Avenue, Tenth Floor and Legislative Services Agency, One North Capitol, Suite 325, Indianapolis, Indiana and are open for public inspection.*

Janet G. McCabe

Assistant Commissioner

Office of Air Management

(b) If the Medicare payment amount for a claim exceeds or equals the Medicaid allowable amount for that claim, Medicaid reimbursement will be zero (0).

(c) If the Medicaid allowable amount for a claim exceeds the Medicare payment amount for that claim, Medicaid reimbursement is the lesser of:

(1) the difference between the Medicaid allowable amount minus the Medicare payment amount; or

(2) the Medicare coinsurance and deductible, if any, for the claim.

**(d) Cross-over claims filed by providers other than nursing facilities are reimbursed as described in section 3 of this rule. (Office of the Secretary of Family and Social Services; 405 IAC 1-18-2; filed Mar 18, 2002, 3:32 p.m.: 25 IR 2477)**

SECTION 2. 405 IAC 1-18-3, AS ADDED AT 25 IR 2476, IS REPEALED.

### **Notice of Public Hearing**

*Under IC 4-22-2-24, notice is hereby given that on July 23, 2002 at 9:00 a.m., at the Indiana Government Center-South, 402 West Washington Street, Conference Center Room 2, Indianapolis, Indiana the Office of the Secretary of Family and Social Services will hold a public hearing on proposed new rules to specify Medicaid reimbursement methodology for Medicare cross-over claims. Copies of these rules are now on file at the Indiana Government Center-South, 402 West Washington Street, Room W451 and Legislative Services Agency, One North Capitol, Suite 325, Indianapolis, Indiana and are open for public inspection.*

John Hamilton

Secretary

Office of the Secretary of Family and Social Services

---

---

## **TITLE 405 OFFICE OF THE SECRETARY OF FAMILY AND SOCIAL SERVICES**

### **Proposed Rule**

LSA Document #02-121

### **DIGEST**

Amends 405 IAC 1-18-2 to specify Medicaid reimbursement methodology for Medicare cross-over claims. Repeals 405 IAC 1-18-3. Effective 30 days after filing with the secretary of state.

#### **405 IAC 1-18-2**

#### **405 IAC 1-18-3**

SECTION 1. 405 IAC 1-18-2, AS ADDED AT 25 IR 2477, SECTION 1, IS AMENDED TO READ AS FOLLOWS:

#### **405 IAC 1-18-2 Reimbursement of cross-over claims**

**Authority:** IC 12-8-6-5; IC 12-15-1-10; IC 12-15-1-15; IC 12-15-21-2; IC 12-15-21-3

**Affected:** IC 12-15-14

Sec. 2. (a) Cross-over claims filed by **nursing facilities Medicaid providers** are reimbursed as set out in this section.

---

---

## **TITLE 410 INDIANA STATE DEPARTMENT OF HEALTH**

### **Proposed Rule**

LSA Document #02-89

### **DIGEST**

Adds 410 IAC 16.2-1.1 to update and add definitions. Amends 410 IAC 16.2-5 to update health and sanitation standards, qualifications of applicants for licensure, requirements for operation, maintenance, and management, and other requirements for the operation of residential care facilities. Repeals 410 IAC 16.2-1, 410 IAC 16.2-5-1.7, 410 IAC 16.2-5-3, 410 IAC 16.2-5-5, 410 IAC 16.2-5-7, 410 IAC 16.2-5-8, 410

## Proposed Rules

IAC 16.2-5-9, 410 IAC 16.2-5-10, and 410 IAC 16.2-5-11.  
Effective March 1, 2003.

410 IAC 16.2-1	410 IAC 16.2-5-5
410 IAC 16.2-1.1	410 IAC 16.2-5-5.1
410 IAC 16.2-5-0.5	410 IAC 16.2-5-6
410 IAC 16.2-5-1.1	410 IAC 16.2-5-7
410 IAC 16.2-5-1.2	410 IAC 16.2-5-7.1
410 IAC 16.2-5-1.3	410 IAC 16.2-5-8
410 IAC 16.2-5-1.4	410 IAC 16.2-5-8.1
410 IAC 16.2-5-1.5	410 IAC 16.2-5-9
410 IAC 16.2-5-1.6	410 IAC 16.2-5-10
410 IAC 16.2-5-1.7	410 IAC 16.2-5-11
410 IAC 16.2-5-2	410 IAC 16.2-5-11.1
410 IAC 16.2-5-3	410 IAC 16.2-5-12
410 IAC 16.2-5-4	

SECTION 1. 410 IAC 16.2-1.1 IS ADDED TO READ AS FOLLOWS:

### Rule 1.1. Definitions

#### 410 IAC 16.2-1.1-1 Applicability

Authority: IC 16-28-1-7; IC 16-28-1-12  
Affected: IC 16-28

Sec. 1. The definitions in this rule apply throughout this article, except as noted. (*Indiana State Department of Health; 410 IAC 16.2-1.1-1*)

#### 410 IAC 16.2-1.1-2 "Abuse" defined

Authority: IC 16-28-1-7; IC 16-28-1-12  
Affected: IC 16-28

Sec. 2. "Abuse" means any physical or mental injury or sexual assault inflicted on a resident in the facility, other than by accidental means. (*Indiana State Department of Health; 410 IAC 16.2-1.1-2*)

#### 410 IAC 16.2-1.1-3 "Activities of daily living" defined

Authority: IC 16-28-1-7; IC 16-28-1-12  
Affected: IC 16-28

Sec. 3. "Activities of daily living" means mobility, eating, dressing, bathing, toileting, and transferring. (*Indiana State Department of Health; 410 IAC 16.2-1.1-3*)

#### 410 IAC 16.2-1.1-4 "Administration of medications" defined

Authority: IC 16-28-1-7; IC 16-28-1-12  
Affected: IC 16-28

Sec. 4. "Administration of medications" means preparation and/or distribution of prescribed medications. This does not include reminders, cues, and/or opening of medication containers or assistance with eye drops, when requested by a resident. (*Indiana State Department of Health; 410 IAC 16.2-1.1-4*)

#### 410 IAC 16.2-1.1-5 "Administrator" defined

Authority: IC 16-28-1-7; IC 16-28-1-12  
Affected: IC 16-28; IC 25-19-1

Sec. 5. "Administrator" means a person holding a valid license under IC 25-19-1. (*Indiana State Department of Health; 410 IAC 16.2-1.1-5*)

#### 410 IAC 16.2-1.1-6 "Advance directives" defined

Authority: IC 16-28-1-7; IC 16-28-1-12  
Affected: IC 16-28

Sec. 6. "Advance directives" means a written instrument, such as a living will or durable power of attorney for health care, recognized under state law, relating to the provision of health care when the individual is incapacitated. (*Indiana State Department of Health; 410 IAC 16.2-1.1-6*)

#### 410 IAC 16.2-1.1-7 "Ambulation" defined

Authority: IC 16-28-1-7; IC 16-28-1-12  
Affected: IC 16-28

Sec. 7. "Ambulation" means walking, once in a standing position. (*Indiana State Department of Health; 410 IAC 16.2-1.1-7*)

#### 410 IAC 16.2-1.1-8 "Assessment" defined

Authority: IC 16-28-1-7; IC 16-28-1-12  
Affected: IC 16-28

Sec. 8. "Assessment" means the identification of an individual's present level of strengths, abilities, and needs; and the conditions that impede the individual's development or functioning. (*Indiana State Department of Health; 410 IAC 16.2-1.1-8*)

#### 410 IAC 16.2-1.1-9 "Bathing" defined

Authority: IC 16-28-1-7; IC 16-28-1-12  
Affected: IC 16-28

Sec. 9. "Bathing" means washing and drying the body (excluding the back and shampooing the hair), including:

- (1) full-body bath;
- (2) sponge bath;
- (3) preparatory activities; and
- (4) transferring into and out of the tub and shower.

(*Indiana State Department of Health; 410 IAC 16.2-1.1-9*)

#### 410 IAC 16.2-1.1-10 "Certification" defined

Authority: IC 16-28-1-7; IC 16-28-1-12  
Affected: IC 16-28

Sec. 10. "Certification" means that the federal Department of Health and Human Services has determined a facility to be in compliance with applicable statutory or regulatory requirements and standards for the purposes of participation as a provider of care and service for Title XVIII or Title XIX, or both, of the federal Social Security Act. (*Indiana State Department of Health; 410 IAC 16.2-1.1-10*)



**410 IAC 16.2-1.1-11 “Children” defined**

Authority: IC 16-28-1-7; IC 16-28-1-12  
Affected: IC 16-28

Sec. 11. “Children” means individuals who:

- (1) are less than eighteen (18) years of age and not legally emancipated; or
- (2) if older:
  - (A) require by the reason of physical or mental handicap, care of the type usually accepted as pediatric; or
  - (B) are suffering from a handicap or ailment which, in the judgment of the attending physician, indicates that the child care facility is more appropriate to their needs than an adult care facility.

*(Indiana State Department of Health; 410 IAC 16.2-1.1-11)*

**410 IAC 16.2-1.1-12 “Comfortable and safe temperature levels” defined**

Authority: IC 16-28-1-7; IC 16-28-1-12  
Affected: IC 16-28

Sec. 12. “Comfortable and safe temperature levels” means that the ambient temperature should be in a relatively narrow range, seventy-one (71) degrees Fahrenheit to eighty-one (81) degrees Fahrenheit, that minimizes residents’ susceptibility to the loss of body heat and risk of hypothermia or susceptibility to respiratory ailments and colds. *(Indiana State Department of Health; 410 IAC 16.2-1.1-12)*

**410 IAC 16.2-1.1-13 “Communicable disease” defined**

Authority: IC 16-28-1-7; IC 16-28-1-12  
Affected: IC 16-28

Sec. 13. “Communicable disease” means communicable disease as defined in 410 IAC 1-2.3-11. *(Indiana State Department of Health; 410 IAC 16.2-1.1-13)*

**410 IAC 16.2-1.1-14 “Comprehensive care facility” defined**

Authority: IC 16-28-1-7; IC 16-28-1-12  
Affected: IC 16-28

Sec. 14. “Comprehensive care facility” means a health facility that provides nursing care, room, food, laundry, administration of medications, special diets, and treatments, and that may provide rehabilitative and restorative therapies under the order of an attending physician. *(Indiana State Department of Health; 410 IAC 16.2-1.1-14)*

**410 IAC 16.2-1.1-15 “Comprehensive nursing care” defined**

Authority: IC 16-28-1-7; IC 16-28-1-12  
Affected: IC 16-28

Sec. 15. “Comprehensive nursing care” includes, but is not limited to, the following:

- (1) Intravenous feedings.
- (2) Enteral feeding.

- (3) Nasopharyngeal and tracheostomy aspiration.
- (4) Insertion and sterile irrigation and replacement of suprapubic catheters.
- (5) Application of dressings to wounds that:
  - (A) require use of sterile techniques, packing, or irrigation; or
  - (B) are infected or otherwise complicated.
- (6) Treatment of Stages 2, 3, and 4 pressure ulcers or other widespread skin disorders.
- (7) Heat treatments that have been specifically ordered by a physician as part of active treatment and require observation by nurses to adequately evaluate the process.
- (8) Initial phases of a regimen involving administration of medical gases.

*(Indiana State Department of Health; 410 IAC 16.2-1.1-15)*

**410 IAC 16.2-1.1-16 “Construction type” defined**

Authority: IC 16-28-1-7; IC 16-28-1-12  
Affected: IC 16-28

Sec. 16. “Construction type” means the type of construction as established by the rules of the fire prevention and building safety commission (675 IAC). *(Indiana State Department of Health; 410 IAC 16.2-1.1-16)*

**410 IAC 16.2-1.1-17 “Convenience” defined**

Authority: IC 16-28-1-7; IC 16-28-1-12  
Affected: IC 16-28

Sec. 17. “Convenience” means any action taken by the facility to control resident behavior or maintain residents with a lesser amount of effort by the facility and not in the resident’s best interest. *(Indiana State Department of Health; 410 IAC 16.2-1.1-17)*

**410 IAC 16.2-1.1-18 “Department” defined**

Authority: IC 16-28-1-7; IC 16-28-1-12  
Affected: IC 16-28

Sec. 18. “Department” means the Indiana state department of health. *(Indiana State Department of Health; 410 IAC 16.2-1.1-18)*

**410 IAC 16.2-1.1-19 “Developmentally disabled” defined**

Authority: IC 16-28-1-7; IC 16-28-1-12  
Affected: IC 16-28

Sec. 19. “Developmentally disabled” means a personal disability that:

- (1) is attributable to:
  - (A) mental retardation, cerebral palsy, epilepsy, or autism;
  - (B) any other condition found to be closely related to mental retardation because this condition results in similar impairment of general intellectual functioning or adaptive behavior, or requires similar treatment and services; or

## Proposed Rules

(C) dyslexia resulting from a disability described in this section;

(2) originates before the person is eighteen (18) years of age; and

(3) has continued or is expected to continue indefinitely and constitutes a substantial handicap to the person's ability to function normally in society.

(Indiana State Department of Health; 410 IAC 16.2-1.1-19)

### 410 IAC 16.2-1.1-20 "Discipline" defined

Authority: IC 16-28-1-7; IC 16-28-1-12

Affected: IC 16-28

Sec. 20. "Discipline" means any action taken by the facility for the express purpose of punishing or penalizing residents. (Indiana State Department of Health; 410 IAC 16.2-1.1-20)

### 410 IAC 16.2-1.1-21 "Division" defined

Authority: IC 16-28-1-7; IC 16-28-1-12

Affected: IC 16-28

Sec. 21. "Division" means the part of the Indiana state department of health responsible for survey, licensure, and enforcement of health facilities. (Indiana State Department of Health; 410 IAC 16.2-1.1-21)

### 410 IAC 16.2-1.1-22 "Dressing" defined

Authority: IC 16-28-1-7; IC 16-28-1-12

Affected: IC 16-28

Sec. 22. "Dressing" means selecting, obtaining, putting on, fastening, and taking off all items of clothing, including donning or removing braces and artificial limbs. (Indiana State Department of Health; 410 IAC 16.2-1.1-22)

### 410 IAC 16.2-1.1-23 "Eating" defined

Authority: IC 16-28-1-7; IC 16-28-1-12

Affected: IC 16-28

Sec. 23. "Eating" means how a resident ingests and drinks, regardless of self-feeding skills. (Indiana State Department of Health; 410 IAC 16.2-1.1-23)

### 410 IAC 16.2-1.1-24 "Emergency" defined

Authority: IC 16-28-1-7; IC 16-28-1-12

Affected: IC 16-28

Sec. 24. "Emergency" means a situation or physical condition that presents imminent danger of death or serious physical or mental harm to one (1) or more residents of a facility. (Indiana State Department of Health; 410 IAC 16.2-1.1-24)

### 410 IAC 16.2-1.1-25 "Exercising rights" defined

Authority: IC 16-28-1-7; IC 16-28-1-12

Affected: IC 16-28

Sec. 25. "Exercising rights" means that the residents have

autonomy and choice, to the maximum extent possible, about how they wish to live their everyday lives and receive care, subject to the facility's rules, as long as those rules do not violate a regulatory requirement. (Indiana State Department of Health; 410 IAC 16.2-1.1-25)

### 410 IAC 16.2-1.1-26 "Functional furniture appropriate to resident's needs" defined

Authority: IC 16-28-1-7; IC 16-28-1-12

Affected: IC 16-28

Sec. 26. "Functional furniture appropriate to resident's needs" means, at a minimum, the following:

(1) A structurally sound dresser or chest of drawers (may be built in).

(2) A night table.

(3) Seating.

(Indiana State Department of Health; 410 IAC 16.2-1.1-26)

### 410 IAC 16.2-1.1-27 "Grooming" defined

Authority: IC 16-28-1-7; IC 16-28-1-12

Affected: IC 16-28

Sec. 27. "Grooming" means maintaining personal hygiene, including the following:

(1) Preparatory activities.

(2) Combing hair.

(3) Washing and drying face, hands, and perineum.

(4) Brushing teeth.

(5) If applicable, shaving or applying makeup.

(Indiana State Department of Health; 410 IAC 16.2-1.1-27)

### 410 IAC 16.2-1.1-28 "Habilitation" defined

Authority: IC 16-28-1-7; IC 16-28-1-12

Affected: IC 16-28

Sec. 28. "Habilitation" means programs and activities designed to help a resident develop and maintain a level of independence and self-sufficiency consistent with individual capabilities and performance levels. (Indiana State Department of Health; 410 IAC 16.2-1.1-28)

### 410 IAC 16.2-1.1-29 "Health care facilities for children" defined

Authority: IC 16-28-1-7; IC 16-28-1-12

Affected: IC 16-28

Sec. 29. "Health care facilities for children" means those facilities that provide nursing care, habilitative and rehabilitative procedures, room, food, and laundry for children who, because of handicaps, require such care. (Indiana State Department of Health; 410 IAC 16.2-1.1-29)

### 410 IAC 16.2-1.1-30 "Health facility license" defined

Authority: IC 16-28-1-7; IC 16-28-1-12

Affected: IC 16-28-2

Sec. 30. "Health facility license" means any instrument

issued pursuant to IC 16-28-2 by the department to any person or persons demonstrating compliance with the laws and rules governing such issuance. (*Indiana State Department of Health; 410 IAC 16.2-1.1-30*)

**410 IAC 16.2-1.1-31 “Highest practicable” defined**

Authority: IC 16-28-1-7; IC 16-28-1-12  
Affected: IC 16-28

Sec. 31. “Highest practicable” means the highest level of functioning and well-being possible, limited by the individual’s present functional status, and potential for improvement or reduced rate of functional decline. (*Indiana State Department of Health; 410 IAC 16.2-1.1-31*)

**410 IAC 16.2-1.1-32 “Home health aide” defined**

Authority: IC 16-28-1-7; IC 16-28-1-12  
Affected: IC 16-28

Sec. 32. “Home health aide” means an individual whose name is on the home health aide registry with no findings. (*Indiana State Department of Health; 410 IAC 16.2-1.1-32*)

**410 IAC 16.2-1.1-33 “Infectious” defined**

Authority: IC 16-28-1-7; IC 16-28-1-12  
Affected: IC 16-28

Sec. 33. “Infectious” means capable of spreading infection. (*Indiana State Department of Health; 410 IAC 16.2-1.1-33*)

**410 IAC 16.2-1.1-34 “Intermediate care facility for the mentally retarded (or persons with related conditions)” defined**

Authority: IC 16-28-1-7; IC 16-28-1-12  
Affected: IC 16-28

Sec. 34. “Intermediate care facility for the mentally retarded (or persons with related conditions)” means a health facility that provides active treatment for each developmentally disabled resident. In addition, the facility provides nursing care, room, food, laundry, administration of medications, modified diets, and treatments. A facility is only for developmentally disabled residents, and the facility shall be designed to enhance the development of these individuals, to maximize achievement through an interdisciplinary approach based on development principles, and to create the least restrictive environment. (*Indiana State Department of Health; 410 IAC 16.2-1.1-34*)

**410 IAC 16.2-1.1-35 “Legal representative” defined**

Authority: IC 16-28-1-7; IC 16-28-1-12  
Affected: IC 16-28; IC 16-36-1-5

Sec. 35. “Legal representative” means a person who is:

- (1) a guardian;
- (2) a health care representative;
- (3) an attorney in fact; or

(4) a person authorized by IC 16-36-1-5 to give health care consent.

(*Indiana State Department of Health; 410 IAC 16.2-1.1-35*)

**410 IAC 16.2-1.1-36 “Licensed practical nurse” or “LPN” defined**

Authority: IC 16-28-1-7; IC 16-28-1-12  
Affected: IC 16-28; IC 25-23-1-12

Sec. 36. “Licensed practical nurse” or “LPN” means an individual as defined in IC 25-23-1-12. (*Indiana State Department of Health; 410 IAC 16.2-1.1-36*)

**410 IAC 16.2-1.1-37 “Licensee” defined**

Authority: IC 16-28-1-7; IC 16-28-1-12  
Affected: IC 16-28-2

Sec. 37. “Licensee” means the individual, partnership, corporation, association, company, and legal successor thereof who holds a valid license issued pursuant to IC 16-28-2. (*Indiana State Department of Health; 410 IAC 16.2-1.1-37*)

**410 IAC 16.2-1.1-38 “Medical records practitioner” defined**

Authority: IC 16-28-1-7; IC 16-28-1-12  
Affected: IC 16-28

Sec. 38. “Medical records practitioner” means a person who is certified as or is eligible for certification as a registered record administrator (RRA) or an accredited record technician (ART) by the American Health Information Management Association under its requirements. (*Indiana State Department of Health; 410 IAC 16.2-1.1-38*)

**410 IAC 16.2-1.1-39 “Medication error” defined**

Authority: IC 16-28-1-7; IC 16-28-1-12  
Affected: IC 16-28

Sec. 39. “Medication error” means a discrepancy between what the physician ordered and what was or was not administered. (*Indiana State Department of Health; 410 IAC 16.2-1.1-39*)

**410 IAC 16.2-1.1-40 “Minor regimens” defined**

Authority: IC 16-28-1-7; IC 16-28-1-12  
Affected: IC 16-28

Sec. 40. “Minor regimens” includes, but is not limited to, the following:

- (1) Assistance with self-maintained exdwelling and indwelling catheter care and intermittent catheterization for a chronic condition.
- (2) Prophylactic and palliative skin care, including application of creams or ointments for treatment of minor skin problems.
- (3) Routine dressing that does not require packing or irrigation, but is for abrasions, skin tears, closed surgical wounds, and chronic skin conditions.

## Proposed Rules

(4) General maintenance care of ostomy, including routine change of bag with care and maintenance of surrounding tissue.

(5) Restorative nursing assistance, including passive and/or active assisted range of motion.

(6) Toileting care includes assistance in use of adult briefs and cues for bowel and bladder training.

(7) Routine blood glucose testing involving a finger-stick method.

(8) Enema and digital stool removal therapies.

(9) General maintenance care in connection with braces, splints, and plaster casts.

(10) Observation of self-maintained prosthetic devices.

(11) Administration of subcutaneous or intramuscular injections.

(12) Metered dose inhalers, nebulizer/aerosol treatments self-administered by a resident and routine administration of medical gases after a therapy regimen has been established.

*(Indiana State Department of Health; 410 IAC 16.2-1.1-40)*

### 410 IAC 16.2-1.1-41 "Misappropriation of property" defined

Authority: IC 16-28-1-7; IC 16-28-1-12

Affected: IC 16-28

Sec. 41. "Misappropriation of property" means the deliberate misplacement, exploitation, or wrongful, temporary, or permanent use of a resident's belongings or money without the resident's consent. *(Indiana State Department of Health; 410 IAC 16.2-1.1-41)*

### 410 IAC 16.2-1.1-42 "Mobile" defined

Authority: IC 16-28-1-7; IC 16-28-1-12

Affected: IC 16-28

Sec. 42. "Mobile" means able to move from place to place by ambulation or with the assistance of a wheelchair or other device. *(Indiana State Department of Health; 410 IAC 16.2-1.1-42)*

### 410 IAC 16.2-1.1-43 "Modified diet" defined

Authority: IC 16-28-1-7; IC 16-28-1-12

Affected: IC 16-28

Sec. 43. "Modified diet" means an adjustment of the regular diet that alters the calorie value, nutritive content, or consistency of the food. *(Indiana State Department of Health; 410 IAC 16.2-1.1-43)*

### 410 IAC 16.2-1.1-44 "Neglect" defined

Authority: IC 16-28-1-7; IC 16-28-1-12

Affected: IC 16-28

Sec. 44. "Neglect" means:

- (1) an act or omission that places a resident in a situation that may endanger the resident's life or health;
- (2) abandoning or cruelly confining the resident;

(3) depriving the resident of necessary support, including food, clothing, shelter, and medical care; or

(4) depriving the resident of education as required by statute.

*(Indiana State Department of Health; 410 IAC 16.2-1.1-44)*

### 410 IAC 16.2-1.1-45 "Nurse aide" defined

Authority: IC 16-28-1-7; IC 16-28-1-12

Affected: IC 16-28

Sec. 45. "Nurse aide" means an individual as defined in 42 CFR 483.75(e)(1). *(Indiana State Department of Health; 410 IAC 16.2-1.1-45)*

### 410 IAC 16.2-1.1-46 "Nurse practitioner" defined

Authority: IC 16-28-1-7; IC 16-28-1-12

Affected: IC 16-28; IC 25-23-1

Sec. 46. "Nurse practitioner" means an individual as defined in IC 25-23-1. *(Indiana State Department of Health; 410 IAC 16.2-1.1-46)*

### 410 IAC 16.2-1.1-47 "Nursing care" defined

Authority: IC 16-28-1-7; IC 16-28-1-12

Affected: IC 16-28

Sec. 47. "Nursing care" means those activities, including:

- (1) identifying human responses to actual or potential health conditions;
- (2) deriving a nursing diagnosis;
- (3) executing a nursing treatment regimen based on the nursing diagnosis;
- (4) teaching health care practices;
- (5) advocating provision of necessary health care services through collaboration with other health service personnel;
- (6) executing regimens as prescribed by a physician, licensed chiropractor, dentist, optometrist, podiatrist, or nurse practitioner; and
- (7) administering, supervising, delegating, and evaluating nursing activities.

*(Indiana State Department of Health; 410 IAC 16.2-1.1-47)*

### 410 IAC 16.2-1.1-48 "Nursing staff" defined

Authority: IC 16-28-1-7; IC 16-28-1-12

Affected: IC 16-28

Sec. 48. "Nursing staff" means, at a minimum, licensed nurses and nurse aides. Nurse aides must meet the training and competency requirements required by the state. *(Indiana State Department of Health; 410 IAC 16.2-1.1-48)*

### 410 IAC 16.2-1.1-49 "Pharmacist" defined

Authority: IC 16-28-1-7; IC 16-28-1-12

Affected: IC 16-28; IC 25-26-13

Sec. 49. "Pharmacist" means an individual as defined in IC 25-26-13. *(Indiana State Department of Health; 410 IAC 16.2-1.1-49)*

**410 IAC 16.2-1.1-50 “Physician” defined**

Authority: IC 16-28-1-7; IC 16-28-1-12  
 Affected: IC 16-28; IC 25-22.5-1-1.1

Sec. 50. “Physician” means an individual as defined in IC 25-22.5-1-1.1. (*Indiana State Department of Health; 410 IAC 16.2-1.1-50*)

**410 IAC 16.2-1.1-51 “Physician orders” defined**

Authority: IC 16-28-1-7; IC 16-28-1-12  
 Affected: IC 16-28

Sec. 51. “Physician orders” means those orders facility staff need to provide essential care to the resident, consistent with the resident’s mental and physical status. At a minimum, these orders include dietary, medications, and routine care to maintain or improve the resident’s functional abilities. (*Indiana State Department of Health; 410 IAC 16.2-1.1-51*)

**410 IAC 16.2-1.1-52 “Policy manual” defined**

Authority: IC 16-28-1-7; IC 16-28-1-12  
 Affected: IC 16-28

Sec. 52. “Policy manual” means a document that details the administrative and operating plan of the facility. (*Indiana State Department of Health; 410 IAC 16.2-1.1-52*)

**410 IAC 16.2-1.1-53 “Psychologist” defined**

Authority: IC 16-28-1-7; IC 16-28-1-12  
 Affected: IC 16-28; IC 25-33-1

Sec. 53. “Psychologist” means a person as defined in IC 25-33-1. (*Indiana State Department of Health; 410 IAC 16.2-1.1-53*)

**410 IAC 16.2-1.1-54 “Qualified medication aide” defined**

Authority: IC 16-28-1-7; IC 16-28-1-12  
 Affected: IC 16-28

Sec. 54. “Qualified medication aide” means an individual who has satisfactorily completed the state qualified medication aide course and test. (*Indiana State Department of Health; 410 IAC 16.2-1.1-54*)

**410 IAC 16.2-1.1-55 “Qualified mental retardation professional” or “QMRP” defined**

Authority: IC 16-28-1-7; IC 16-28-1-12  
 Affected: IC 16-28; IC 25-22.5-5; IC 25-23-1-11; IC 25-27; IC 25-35.6-3

Sec. 55. “Qualified mental retardation professional” or “QMRP” means a person who has specialized training or one (1) year of experience in treating the mentally retarded, and is one (1) of the following:

- (1) A psychologist with a master’s degree from an accredited program.
- (2) A licensed doctor of medicine or osteopathy.

(3) An educator with a degree in education from an accredited program.

(4) A social worker with a bachelor’s or master’s degree in social work from an accredited program or a bachelor’s or master’s degree in a field other than social work and at least three (3) years of social work experience under the supervision of a qualified social worker.

(5) An occupational therapist who:

(A) is a graduate of an occupational therapy curriculum accredited jointly by the council on medical education of the American Medical Association and the American Occupational Therapy Association;

(B) is eligible for certification by the American Occupational Therapy Association under its requirements in effect on September 29, 1978; or

(C) has two (2) years of appropriate experience as an occupational therapist and has achieved a satisfactory grade on the approved proficiency examination, except that such determinations of proficiency shall not apply with respect to persons initially licensed by the state or seeking initial qualifications as an occupational therapist after December 31, 1977.

(6) A speech pathologist or audiologist licensed pursuant to IC 25-35.6-3.

(7) A registered nurse licensed pursuant to IC 25-23-1-11.

(8) A therapeutic recreation specialist who is a graduate of an accredited program.

(9) A rehabilitative counselor who is certified by the Committee of Rehabilitation Counselor Certification.

(10) A physical therapist who is licensed pursuant to IC 25-27.

(*Indiana State Department of Health; 410 IAC 16.2-1.1-55*)

**410 IAC 16.2-1.1-56 “Range of motion” defined**

Authority: IC 16-28-1-7; IC 16-28-1-12  
 Affected: IC 16-28

Sec. 56. “Range of motion” means the extent of movement of a joint. (*Indiana State Department of Health; 410 IAC 16.2-1.1-56*)

**410 IAC 16.2-1.1-57 “Recreation area” defined**

Authority: IC 16-28-1-7; IC 16-28-1-12  
 Affected: IC 16-28

Sec. 57. “Recreation area” means:

(1) an area where residents can enjoy fresh air, either inside or outside the facility, for example:

- (A) balcony;
- (B) porch;
- (C) patio;
- (D) courtyard; or
- (E) solarium; and

(2) an inside area used primarily for activities organized by the facility.

(*Indiana State Department of Health; 410 IAC 16.2-1.1-57*)

## Proposed Rules

### 410 IAC 16.2-1.1-58 "Registered nurse" or "RN" defined

Authority: IC 16-28-1-7; IC 16-28-1-2  
Affected: IC 16-28; IC 25-23-1-11

Sec. 58. "Registered nurse" or "RN" means an individual as defined in IC 25-23-1-11. (*Indiana State Department of Health; 410 IAC 16.2-1.1-58*)

### 410 IAC 16.2-1.1-59 "Rehabilitation" defined

Authority: IC 16-28-1-7; IC 16-28-1-12  
Affected: IC 16-28

Sec. 59. "Rehabilitation" means programs and activities implemented as a component of a treatment plan or in support of a plan to restore a resident to his or her optimal level of physical and psychosocial functions. (*Indiana State Department of Health; 410 IAC 16.2-1.1-59*)

### 410 IAC 16.2-1.1-60 "Rehabilitative therapy" defined

Authority: IC 16-28-1-7; IC 16-28-1-12  
Affected: IC 16-28

Sec. 60. "Rehabilitative therapy" means:

- (1) physical therapy;
- (2) occupational therapy;
- (3) respiratory therapy;
- (4) speech therapy;
- (5) mental health therapy; and
- (6) other medically-recognized therapies.

(*Indiana State Department of Health; 410 IAC 16.2-1.1-60*)

### 410 IAC 16.2-1.1-61 "Resident" defined

Authority: IC 16-28-1-7; IC 16-28-1-12  
Affected: IC 16-28

Sec. 61. "Resident" means a person residing and receiving care in a health facility. For purposes of exercising the resident's rights, such rights may be exercised by the resident or his or her legal representative. (*Indiana State Department of Health; 410 IAC 16.2-1.1-61*)

### 410 IAC 16.2-1.1-62 "Residential care facility" defined

Authority: IC 16-28-1-7; IC 16-28-1-12  
Affected: IC 16-28

Sec. 62. "Residential care facility" means a health care facility that provides residential nursing care. (*Indiana State Department of Health; 410 IAC 16.2-1.1-62*)

### 410 IAC 16.2-1.1-63 "Residential nursing care" defined

Authority: IC 16-28-1-7; IC 16-28-1-12  
Affected: IC 16-28

Sec. 63. "Residential nursing care" may include, but is not limited to, the following:

- (1) Identifying human responses to actual or potential health conditions.
- (2) Deriving a nursing diagnosis.

(3) Executing a minor regimen based on a nursing diagnosis or executing minor regimens as prescribed by a physician, physician assistant, chiropractor, dentist, optometrist, podiatrist, or nurse practitioner.

(4) Administering, supervising, delegating, and evaluating nursing activities as described in this section.

(*Indiana State Department of Health; 410 IAC 16.2-1.1-63*)

### 410 IAC 16.2-1.1-64 "Respiratory therapy" defined

Authority: IC 16-28-1-7; IC 16-28-1-12  
Affected: IC 16-28; IC 25-34.5-1-6

Sec. 64. "Respiratory therapy" means medical specialty primarily concerned with the treatment and care of persons with deficiencies and abnormalities associated with the cardiopulmonary system, and includes those activities set forth in IC 25-34.5-1-6. (*Indiana State Department of Health; 410 IAC 16.2-1.1-64*)

### 410 IAC 16.2-1.1-65 "Respite care" defined

Authority: IC 16-28-1-7; IC 16-28-1-12  
Affected: IC 16-28

Sec. 65. "Respite care" means the provision by a facility of room, board, and care up to the level ordinarily provided for permanent residents of the facility to a person for not more than one (1) month for each stay in the facility. (*Indiana State Department of Health; 410 IAC 16.2-1.1-65*)

### 410 IAC 16.2-1.1-66 "Restraint" defined

Authority: IC 16-28-1-7; IC 16-28-1-12  
Affected: IC 16-28

Sec. 66. "Restraint" means a device or method, including chemical means, used to limit the activity or aggressiveness of a resident where such activity or aggressiveness could be harmful to the resident or others. (*Indiana State Department of Health; 410 IAC 16.2-1.1-66*)

### 410 IAC 16.2-1.1-67 "Seclusion" defined

Authority: IC 16-28-1-7; IC 16-28-1-12  
Affected: IC 16-28

Sec. 67. "Seclusion" means any circumscribed area in which a person is maintained alone and under surveillance, with the area so equipped that the person may not leave without assistance. (*Indiana State Department of Health; 410 IAC 16.2-1.1-67*)

### 410 IAC 16.2-1.1-68 "Self-limiting condition" defined

Authority: IC 16-28-1-7; IC 16-28-1-12  
Affected: IC 16-28

Sec. 68. "Self-limiting condition" means the condition will normally resolve itself without further intervention or by staff implementing standard disease related clinical interventions. (*Indiana State Department of Health; 410 IAC 16.2-1.1-68*)

**410 IAC 16.2-1.1-69 “Service plan” defined**

Authority: IC 16-28-1-7; IC 16-28-1-12  
Affected: IC 16-28

Sec. 69. “Service plan” means a written plan for services to be provided by the facility, developed by the facility, the resident and others, if appropriate, on behalf of the resident, consistent with the services needed to ensure the health and welfare of the resident. *(Indiana State Department of Health; 410 IAC 16.2-1.1-69)*

**410 IAC 16.2-1.1-70 “Significant change” defined**

Authority: IC 16-28-1-7; IC 16-28-1-12  
Affected: IC 16-28

Sec. 70. “Significant change” means a major improvement or decline in the resident’s physical, mental, or psychosocial status. *(Indiana State Department of Health; 410 IAC 16.2-1.1-70)*

**410 IAC 16.2-1.1-71 “Sufficient space” defined**

Authority: IC 16-28-1-7; IC 16-28-1-12  
Affected: IC 16-28

Sec. 71. “Sufficient space” means the resident can access the area unless it is functionally off-limits, and the resident’s functioning is not restricted once access to the space is gained. *(Indiana State Department of Health; 410 IAC 16.2-1.1-71)*

**410 IAC 16.2-1.1-72 “Supervise” defined**

Authority: IC 16-28-1-7; IC 16-28-1-12  
Affected: IC 16-28

Sec. 72. “Supervise” means to instruct an employee or subordinate in his or her duties and to oversee or direct work, but does not necessarily require immediate presence of the supervisor. *(Indiana State Department of Health; 410 IAC 16.2-1.1-72)*

**410 IAC 16.2-1.1-73 “Therapist” defined**

Authority: IC 16-28-1-7; IC 16-28-1-12  
Affected: IC 16-28

Sec. 73. “Therapist” means a person who holds a valid license issued pursuant to Indiana statute or is certified or registered by the appropriate body to practice and who has completed the approved educational curriculum. *(Indiana State Department of Health; 410 IAC 16.2-1.1-73)*

**410 IAC 16.2-1.1-74 “Toileting” defined**

Authority: IC 16-28-1-7; IC 16-28-1-12  
Affected: IC 16-28

Sec. 74. “Toileting” means how the resident:  
(1) uses the toilet room (or bedpan, bedside commode, or urinal);  
(2) transfers on and off the toilet;

- (3) cleanses self after elimination;
- (4) changes sanitary napkins or incontinence pads or external catheters; and
- (5) adjusts clothing prior to and after using the toilet.

*(Indiana State Department of Health; 410 IAC 16.2-1.1-74)*

**410 IAC 16.2-1.1-75 “Toileting care” defined**

Authority: IC 16-28-1-7; IC 16-28-1-12  
Affected: IC 16-28

Sec. 75. “Toileting care” means provision of care before and after use of the toilet room, commode, bedpan, or urinal. It includes transferring on and off the toilet, or both, cleansing, pad change, and changing of soiled clothing. *(Indiana State Department of Health; 410 IAC 16.2-1.1-75)*

**410 IAC 16.2-1.1-76 “Total health status” defined**

Authority: IC 16-28-1-7; IC 16-28-1-12  
Affected: IC 16-28

Sec. 76. “Total health status” includes the following:

- (1) Functional status.
- (2) Medical care.
- (3) Nursing care.
- (4) Nutritional status.
- (5) Rehabilitation and restorative potential.
- (6) Activities potential.
- (7) Cognitive status.
- (8) Oral health status.
- (9) Psychosocial status.
- (10) Sensory and physical impairments.

*(Indiana State Department of Health; 410 IAC 16.2-1.1-76)*

**410 IAC 16.2-1.1-77 “Transfer” defined**

Authority: IC 16-28-1-7; IC 16-28-1-12  
Affected: IC 16-28

Sec. 77. “Transfer” means moving between two (2) surfaces, to or from a:

- (1) bed;
- (2) chair;
- (3) wheelchair; or
- (4) standing position.

The term does not include transfer to or from the bath or toilet. This section does not apply to transfer and discharge of residents pursuant to 410 IAC 16.2-3.1 and 410 IAC 16.2-5. *(Indiana State Department of Health; 410 IAC 16.2-1.1-77)*

**410 IAC 16.2-1.1-78 “Written” defined**

Authority: IC 16-28-1-7; IC 16-28-1-12  
Affected: IC 16-28

Sec. 78. “Written” means handwritten, typewritten, or contained on electronic media. *(Indiana State Department of Health; 410 IAC 16.2-1.1-78)*

SECTION 2. 410 IAC 16.2-5-0.5 IS ADDED TO READ AS FOLLOWS:

## Proposed Rules

### 410 IAC 16.2-5-0.5 Scope of residential care facilities

Authority: IC 16-28-1-7; IC 16-28-1-12

Affected: IC 16-28-2; IC 16-28-5-1

**Sec. 0.5. (a) A health facility that provides residential nursing care or administers medications prescribed by a physician must be licensed as a residential care facility. A health facility licensed as a comprehensive care facility is not required to also be licensed as a residential care facility in order to provide residential nursing care.**

**(b) A residential care facility may not provide comprehensive nursing care except to the extent allowed under this rule.**

**(c) A facility that provides services such as room, meals, laundry, activities, housekeeping, and limited assistance in activities of daily living without providing administration of medication or residential nursing care is not required to be licensed.**

**(d) A resident requiring less than twenty-four (24) hour comprehensive nursing care, comprehensive nursing oversight, or rehabilitative therapies, must either enter into a contract with an appropriately licensed provider of his or her choice or be discharged, except that a residential care facility that retains appropriate professional staff may provide comprehensive nursing care to residents needing care for a self-limiting condition.**

**(e) Unless the resident is receiving hospice services or Medicaid for assisted living services, the resident must be discharged if the resident:**

**(1) requires total assistance in two (2) or more of the following activities of daily living on a continual basis:**

**(A) Toileting.**

**(B) Transferring.**

**(C) Eating.**

**(2) requires twenty-four (24) hour comprehensive nursing care or oversight, except as provided under subsection (d); or**

**(3) is a danger to the resident or others.**

**(f) For purposes of IC 16-28-5-1, a breach of:**

**(1) subsection (a) or (b) is an offense; and**

**(2) subsection (c), (d), or (e) is a deficiency.**

*(Indiana State Department of Health; 410 IAC 16.2-5-0.5)*

SECTION 3. 410 IAC 16.2-5-1.1 IS AMENDED TO READ AS FOLLOWS:

### 410 IAC 16.2-5-1.1 Licenses

Authority: IC 16-28-1-7; IC 16-28-1-12

Affected: IC 16-18-2-167; IC 16-28-1-10; IC 16-28-2-2; IC 16-28-2-4; IC 16-28-5-7

Sec. 1.1. (a) Any person, in order to lawfully operate a health

facility as defined in IC 16-18-2-167, shall first obtain an authorization to occupy the facility or a license from the director. The applicant shall notify the director, in writing, before ~~it~~ **the applicant** begins to operate a facility that is being purchased or leased from another licensee. Failure to notify the director precludes the issuance of a full license.

(b) An application shall be submitted on the prescribed form in accordance with IC 16-28-2-2. The application shall include identification of direct or indirect ownership interest of five percent (5%) or more and of corporate officers or partners.

(c) Any change in direct or indirect corporate ownership of five percent (5%) or more ~~that of the licensee, which~~ occurs during the licensure period, shall be reported to the director, in writing, at the time ~~of~~ the change. ~~occurs~~. The facility must also provide written notice at the time the change occurs in the ~~officers, directors, agents, or managing employees, or the~~ corporation, association, or other company responsible for the management of the facility.

(d) A license for a new facility, an existing facility that proposes a change in the number of beds, or a facility that has changed ownership is obtained as follows:

(1) Prior to the start of construction, detailed architectural and operational plans shall be submitted through the office of the state building commissioner to the division for consideration and approval. The plans shall state the licensure classification sought. Plans for projects involving less than thirty thousand (30,000) cubic feet require suitable detailed plans and sketches. Plans for projects involving more than thirty thousand (30,000) cubic feet require certification by an architect or an engineer registered in Indiana. A plan of operation, in sufficient detail to facilitate the review of functional areas, that is, nursing unit, laundry, and kitchen, shall accompany the submitted plan.

(2) Upon receipt of a design release from the state building commissioner and the state fire marshal, an application shall be submitted to the director on the form provided and approved by the ~~division, department,~~ with the documents required by the application form.

(3) Information and supporting documents that the facility will be operated in reasonable compliance with this article and applicable statutes shall be furnished.

(4) A report by the state fire marshal that the facility is in reasonable compliance with the fire safety rules of the fire prevention and building safety commission (675 IAC) shall be furnished.

(5) If new construction or remodeling is involved, information verified by the appropriate building official that the building is in reasonable compliance with the building rules of the ~~department of fire prevention and building services~~ **safety commission** (675 IAC) shall be furnished.

(6) A plan of operation shall be submitted to the director. The plan shall include, but is not limited to, **the following:**



- (A) Corporate or partnership structure.
  - (B) Policies and procedures, including personnel, operations, and resident care.
  - (C) A disaster plan. ~~and~~
  - (D) A copy of agreements and contracts.
  - (7) The appropriate licensure fee shall be submitted.
- (e) The director may approve occupancy and use of the structure pending a final licensure decision.
- (f) The director may issue a provisional license to a new facility or to a facility under new ownership in accordance with IC 16-28-2-4(2).
- (g) For the renewal of a license, the director may issue a full license for any period up to one (1) year or a probationary license, or the director may refuse to issue a license as follows:
- (1) The facility shall submit a renewal application to the director at least forty-five (45) days prior to the expiration of the license. The renewal application shall be on a form provided and approved by the division, ~~that which~~ includes identification of direct or indirect ownership interest of five percent (5%) or more and of corporate officers or partners.
  - (2) The licensure fee shall be included with the renewal application.
  - (3) The director shall verify that the facility is operated in reasonable compliance with IC 16-28-2 and this article.
  - (4) The state fire marshal shall verify that the facility is in reasonable compliance with the applicable fire safety statutes and rules (675 IAC).
- (h) If the director issues a probationary license, the license may be granted for a period of three (3) months. However, no more than three (3) probationary licenses may be issued in a twelve (12) month period. Although the license fee for a full twelve (12) month period has been paid, a new fee shall be required prior to the issuance of a probationary license.
- (i) If the director denies renewal or reduces, revokes, or issues a probationary license, then a hearing officer will be appointed to hold a hearing. However, a facility may waive its right to a hearing and accept the director recommendation.
- (j) For a good cause shown, waiver of any nonstatutory provisions of this rule may be granted by the executive board for a specified period in accordance with IC 16-28-1-10.
- (k) A licensure survey finding or complaint allegation does not constitute a breach for the purposes of IC 16-28-2 until or unless the commissioner makes a specific determination that a breach has occurred. Moreover, the director shall issue a citation only upon a determination by the commissioner that a breach has occurred. Regardless of whether the commissioner makes a determination that a breach has occurred, a licensure survey finding or complaint allegation may be used as evidence as to whether a violation actually occurred for the purposes of

licensure hearings or any other proceedings initiated under IC 16-28-2 or this article.

(1) The classification of rules into the categories that are stated at the end of each section of ~~410 IAC 16.2-3.1~~; this rule and 410 IAC 16.2-6 through 410 IAC 16.2-7 shall be used to determine the corrective actions and penalties, if appropriate, to be imposed by the commissioner upon a determination that a breach has occurred as follows:

(1) An offense presents a substantial probability that death or a life-threatening condition will result. For an offense, the commissioner shall issue an order for immediate correction of the offense. In addition, the commissioner ~~may~~ **shall:**

(A) impose a fine not to exceed ten thousand dollars (\$10,000); or

(B) order the suspension of new admissions to the health facility for a period not to exceed forty-five (45) days;

or both. If the offense is immediately corrected, the commissioner may waive up to fifty percent (50%) of any fine imposed and reduce the number of days for suspension of new admissions by one-half (½). The ~~director~~ **commissioner may revoke also impose revocation by the director of the facility's license or issue issuance of a probationary license.**

(2) A deficiency presents an immediate or direct, serious adverse effect on the health, safety, security, rights, or welfare of a resident. For a deficiency, the commissioner shall issue an order for immediate correction of the deficiency. In addition, the commissioner may:

~~(A) order the suspension of new admissions to the health facility for a period not to exceed thirty (30) days; or~~

~~(B) (A) impose a fine not to exceed five thousand dollars (\$5,000) if the facility holds a probationary license or if the breach is a repeat of the same deficiency within a twelve (12) month period; ten thousand dollars (\$10,000); or~~

~~(B) order the suspension of new admissions to the health facility for a period not to exceed thirty (30) days;~~

or both. ~~However, the commissioner shall impose a fine upon the occurrence of the first deficiency, regardless of the licensure status of the facility, if the first deficiency is intentional or is the result of gross negligence. For a repeat of the same deficiency within a fifteen (15) month period, the commissioner shall order immediate correction of the deficiency, and impose a fine not to exceed ten thousand dollars (\$10,000), or suspension of new admissions to the facility for a period not to exceed forty-five (45) days, or both. If the deficiency is immediately corrected, the commissioner may waive up to fifty percent (50%) of any fine imposed and reduce the number of days for suspension of new admissions by one-half (½). The commissioner may also impose revocation by the director of the facility license or issuance of a probationary license.~~

(3) A noncompliance presents an indirect threat on the health, safety, security, rights, or welfare of a resident. For a non-compliance, the commissioner shall require the health facility

## Proposed Rules

to submit a plan of correction **approved or directed** under IC 16-28-5-7. If the facility is found to have a pattern of noncompliance, the commissioner may suspend new admissions to the health facility for a period not to exceed ten (10) days **or impose a fine not to exceed one thousand dollars (\$1,000), or both.** Additionally, if the health facility is found to have a repeat of the same noncompliance in any eighteen (18) month period, **the commissioner shall issue an order for immediate correction of the noncompliance.** The commissioner may impose a fine not to exceed ~~one thousand~~ **five thousand dollars (\$1,000) (\$5,000) or suspension of new admissions to the health facility for a period not to exceed thirty (30) days, or both.**

(4) A nonconformance is any other classified rule that does not fall in the three (3) categories established in subdivisions (1) through (3). For a nonconformance, the commissioner ~~may request~~ **shall require** the health facility to ~~submit a~~ **comply with any** plan of correction **approved or directed** in accordance with IC 16-28-5-7. **For a repeat of the same nonconformance within a fifteen (15) month period, the commissioner shall require the health facility to comply with any plan of correction approved or directed in accordance with IC 16-28-5-7. For a repeat pattern of nonconformance, the commissioner may suspend new admissions to the health facility for a period not to exceed fifteen (15) days or impose a fine not to exceed one thousand dollars (\$1,000), or both.**

*(Indiana State Department of Health; 410 IAC 16.2-5-1.1; filed Jan 10, 1997, 4:00 p.m.: 20 IR 1560, eff Apr 1, 1997; errata filed Apr 10, 1997, 12:15 p.m.: 20 IR 2415; readopted filed Jul 11, 2001, 2:23 p.m.: 24 IR 4234)*

SECTION 4. 410 IAC 16.2-5-1.2 IS AMENDED TO READ AS FOLLOWS:

### 410 IAC 16.2-5-1.2 Residents' rights

Authority: IC 16-28-1-7; IC 16-28-1-12

Affected: IC 4-21.5; IC 12-10-15-9; IC 16-28-5-1

Sec. 1.2. (a) Residents have the right to have their rights recognized by the licensee. The licensee shall establish written policies regarding residents' rights and responsibilities in accordance with this article and shall be responsible, through the administrator, for their implementation. These policies and any adopted additions or changes thereto shall be made available to the resident, staff, legal representative, and general public. Each resident shall be advised of ~~these residents'~~ rights prior to admission and shall signify, in writing, upon admission and thereafter if the residents' rights are updated or changed. ~~receipt of the described rights and responsibilities. There shall be documentation that each resident is in receipt of the described residents' rights and responsibilities. A copy of the residents' rights must be available in a publicly accessible area. The copy must be in at least 12-point type and a language the resident understands.~~

**(b) Residents have the right to a dignified existence, self-determination, and communication with and access to persons and services inside and outside the facility. Residents have the right to exercise their rights as a resident of the facility and as a citizen or resident of the United States.**

~~(b)~~ (c) Residents have the right to exercise any or all of the enumerated rights without restraint, interference, coercion, discrimination, or threat of reprisal by the facility. These rights shall not be abrogated or changed in any instance, except that, when the resident has been adjudicated incompetent, the rights devolve to the resident's legal representative. When a resident is found by his or her physician to be medically incapable of understanding or exercising his or her rights, the rights may be exercised by the resident's legal representative.

~~(c)~~ (d) Residents have the right to be treated with consideration, respect, and recognition of their dignity and individuality.

~~(d)~~ (e) Residents have the right to be provided, at the time of admission to the facility, **the following:**

(1) **A copy of his or her admission agreement.**

(2) A written notice of the facility's basic daily or monthly rates.

(3) A written statement of all facility services (including those offered on ~~a need an as needed~~ basis).

(4) Information on related charges, ~~and~~ admission, readmission, and discharge policies **of the facility.**

(5) **The facility's policy on voluntary termination of the admission agreement by the resident, including the disposition of any entrance fees or deposits paid on admission. The admission agreement shall include at least those items provided for in IC 12-10-15-9.**

**(f) Residents have the right to be informed of any facility policy regarding overnight guests. This policy shall be clearly stated in the admission agreement.**

~~(e)~~ (g) Residents have the right to be informed by the facility, in writing, at least thirty (30) days in advance of the effective date, of any changes in the rates or services that these rates cover.

**(h) The facility must furnish on admission the following:**

(1) **A statement that the resident may file a complaint with the director concerning resident abuse, neglect, misappropriation of resident property, and other practices of the facility.**

(2) **The most recently known addresses and telephone numbers of the following:**

(A) The department.

(B) The office of the secretary of family and social services.

(C) The ombudsman designated by the division of disability, aging, and rehabilitation services.

- (D) The area agency on aging.
- (E) The local mental health center.
- (F) Adult protective services.

The addresses and telephone numbers in this subdivision shall be posted in an area accessible to residents and updated as appropriate.

(i) The facility will distribute to each resident upon admission the state developed written description of law concerning advance directives.

~~(j)~~ (j) Residents have the right to **the following:**

- (1) Participate in the ~~treatment plan~~ development of his or her service plan and in any updates of that service plan.
- (2) Choose the attending physician and other providers of services, **including arranging for on-site health care services unless contrary to facility policy. Any limitation on the resident's right to choose the attending physician and/or service provider shall be clearly stated in the admission agreement. Other providers of services, within the content of this subsection, may include home health care agencies, hospice care services, or hired individuals.**
- (3) be fully informed of their medical condition by the physician; **Have a pet of his or her choice, so long as the pet does not pose a health or safety risk to residents, staff, or visitors, or a risk to property unless prohibited by facility policy. Any limitation on the resident's right to have a pet of his or her choice shall be clearly stated in the admission agreement.**
- (4) Refuse any treatment or service, including medication.
- (5) Be informed of the medical consequences of such a refusal **under subdivision (4)** and have such data recorded in his or her clinical record, **and if treatment or medication is administered by the facility.**
- (6) Be afforded confidentiality of treatment. ~~The resident may~~
- (7) Participate or refuse to participate in experimental research. ~~and~~ There must be written acknowledgment of informed consent prior to participation in research activities.

(k) **The facility must immediately consult the resident's physician and the resident's legal representative when the facility has noticed:**

- (1) a significant decline in the resident's physical, mental, or psychosocial status; or
- (2) a need to alter treatment significantly, that is, a need to discontinue an existing form of treatment due to adverse consequences or to commence a new form of treatment.

(l) **If the facility participates in the Medicaid waiver and/or residential care assistance programs, the facility must provide to residents written information about how to apply for Medicaid benefits and room and board assistance.**

(m) **The facility must promptly notify the resident and, if known, the resident's legal representative, when there is a change in roommate assignment.**

(n) **Residents may, throughout the period of their stay, voice grievances to the facility staff or to an outside representative of their choice, recommend changes in policy and procedure, and receive reasonable responses to their requests without fear of reprisal or interference.**

~~(o)~~ (o) Residents have the right to form and participate in a resident council, **and families of residents have the right to form a family council**, to discuss alleged grievances, facility operation, resident rights, or other problems, and to participate in the resolution of these matters as follows:

- (1) Participation is voluntary.
- (2) During resident or family council meetings, privacy shall be afforded **to the extent practicable** unless a member of the staff is invited by the resident council to be present.
- (3) The licensee shall provide space **within the facility** for meetings and assistance to residents or families who desire to attend meetings.
- (4) **The facility shall develop and implement policies for investigating and responding to complaints when made known and grievances made by:**
  - (A) an individual resident;
  - (B) a resident council and/or family council;
  - (C) a family member;
  - (D) family groups; or
  - (E) other individuals.

(p) **Residents have the right to the examination of the results of the most recent annual survey of the facility conducted by the state surveyors and any plan of correction in effect with respect to the facility, and any subsequent surveys.**

~~(q)~~ (q) Residents have the right to appropriate housing assignments as follows:

- (1) When both husband and wife are residents in the facility, they have the right to live as a family in a suitable room or quarters ~~if practical~~, and may occupy a double bed unless contraindicated for medical reasons by the attending physician.
- (2) Written facility policy and procedures shall address the circumstances in which persons of the opposite sex, other than husband and wife, will be allowed to occupy a bedroom, if such an arrangement is agreeable to the residents or the residents' legal representatives.

~~(r)~~ (r) The transfer and discharge rights of residents of a facility are as follows:

- (1) As used in this section, "interfacility transfer and discharge" means the movement of a resident to a bed outside of the licensed facility.

## Proposed Rules

- (2) As used in this section, “intrafacility transfer” means the movement of a resident to a bed within the same licensed facility.
- (3) When a transfer or discharge of a resident is proposed, whether intrafacility or interfacility, provision for continuity of care shall be provided by the facility.
- (4) Health facilities must permit each resident to remain in the facility and not transfer or discharge the resident from the facility unless:
- (A) the transfer or discharge is necessary for the resident’s welfare and the resident’s needs cannot be met in the facility;
  - (B) the transfer or discharge is appropriate because the resident’s health has improved sufficiently so that the resident no longer needs the services provided by the facility;
  - (C) the safety of individuals in the facility is endangered;
  - (D) the health of individuals in the facility would otherwise be endangered;
  - (E) the resident has failed, after reasonable and appropriate notice, to pay for a stay at the facility; or
  - (F) the facility ceases to operate.
- (5) When the facility proposes to transfer or discharge a resident under any of the circumstances specified in subdivision (4)(A), (4)(B), (4)(C), (4)(D), or (4)(E), the resident’s clinical records must be documented. The documentation must be made by the following:
- (A) The resident’s physician when transfer or discharge is necessary under subdivision (4)(A) or (4)(B).
  - (B) Any physician when transfer or discharge is necessary under subdivision (4)(D).
- (6) Before an interfacility transfer or discharge occurs, the facility must, on a form prescribed by the department, do the following:
- (A) Notify the resident of the transfer or discharge and the reasons for the move, in writing, and in a language and manner that the resident understands. The health facility must place a copy of the notice in the resident’s clinical record and transmit a copy to the following:
    - (i) The resident.
    - (ii) A family member of the resident if known.
    - (iii) The resident’s legal representative if known.
    - (iv) The local long term care ombudsman program (for involuntary relocations or discharges only).
    - (v) The person or agency responsible for the resident’s placement, maintenance, and care in the facility.
    - (vi) In situations where the resident is developmentally disabled, the regional office of the division of disability, aging, and rehabilitative services, who may assist with placement decisions.
    - (vii) The resident’s physician when the transfer or discharge is necessary under subdivision (4)(C), (4)(D), (4)(E), or (4)(F).
  - (B) Record the reasons in the resident’s clinical record.
  - (C) Include in the notice the items described in subdivision (9).
- (7) Except when specified in subdivision (8), the notice of transfer or discharge required under subdivision (6) must be made by the facility at least thirty (30) days before the resident is transferred or discharged.
- (8) Notice may be made as soon as practicable before transfer or discharge when:
- (A) the safety of individuals in the facility would be endangered;
  - (B) the health of individuals in the facility would be endangered;
  - (C) the resident’s health improves sufficiently to allow a more immediate transfer or discharge;
  - (D) an immediate transfer or discharge is required by the resident’s urgent medical needs; or
  - (E) a resident has not resided in the facility for thirty (30) days.
- (9) For health facilities, the written notice specified in subdivision (7) must include the following:
- (A) The reason for transfer or discharge.
  - (B) The effective date of transfer or discharge.
  - (C) The location to which the resident is transferred or discharged.
  - (D) A statement in not smaller than 12-point bold type that reads, “You have the right to appeal the health facility’s decision to transfer you. If you think you should not have to leave this facility, you may file a written request for a hearing with the Indiana state department of health post-marked within ten (10) days after you receive this notice. If you request a hearing, it will be held within twenty-three (23) days after you receive this notice, and you will not be transferred from the facility earlier than thirty-four (34) days after you receive this notice of transfer or discharge unless the facility is authorized to transfer you under subdivision (8). If you wish to appeal this transfer or discharge, a form to appeal the health facility’s decision and to request a hearing is attached. If you have any questions, call the Indiana state department of health at the number listed below.”.
  - (E) The name of the director and the address, telephone number, and hours of operation of the division.
  - (F) A hearing request form prescribed by the department.
  - (G) The name, address, and telephone number of the state and local long term care ombudsman.
  - (H) For health facility residents with developmental disabilities or who are mentally ill, the mailing address and telephone number of the protection and advocacy services commission.
- (10) If the resident appeals the transfer or discharge, the health facility may not transfer or discharge the resident within thirty-four (34) days after the resident receives the initial transfer or discharge notice, unless an emergency exists as provided under subdivision (8).
- (11) If nonpayment is the basis of a transfer or discharge, the resident shall have the right to pay the balance owed to the facility up to the date of the transfer or discharge and then is entitled to remain in the facility.

(12) The department shall provide a resident who wishes to appeal the transfer or discharge from a facility the opportunity to file a request for a hearing postmarked within ten (10) days following the resident's receipt of the written notice of the transfer or discharge from the facility.

(13) If a health facility resident requests a hearing, the department shall hold an informal hearing at the health facility within twenty-three (23) days from the date the resident receives the notice of transfer or discharge. The department shall attempt to give at least five (5) days' written notice to all parties prior to the informal hearing. The department shall issue a decision within thirty (30) days from the date the resident receives the notice. The health facility must convince the department by a preponderance of the evidence that the transfer or discharge is authorized under subdivision (4). If the department determines that the transfer is appropriate, the resident must not be required to leave the health facility within the thirty-four (34) days after the resident's receipt of the initial transfer or discharge notice unless an emergency exists under subdivision (8). Both the resident and the health facility have the right to administrative or judicial review under IC 4-21.5 of any decision or action by the department arising under this section. All hearings held de novo shall be held in the facility where the resident resides.

(14) An intrafacility transfer can be made only if:

- (A) the transfer is necessary for medical reasons as judged by the attending physician; or
- (B) the transfer is necessary for the welfare of the resident or other persons.

(15) If an intrafacility transfer is required, the resident must be given notice at least two (2) days before relocation, except when:

- (A) the safety of individuals in the facility would be endangered;
- (B) the health of individuals in the facility would be endangered;
- (C) the resident's health improves sufficiently to allow a more immediate transfer; or
- (D) an immediate transfer is required by the resident's urgent medical needs.

(16) The written notice of an intrafacility transfer must include the following:

- (A) Reasons for transfer.
- (B) Effective date of transfer.
- (C) Location to which the resident is to be transferred.
- (D) Name, address, and telephone number of the local and state long term care ombudsman.
- (E) For health facility residents with developmental disabilities or who are mentally ill, the mailing address and telephone number of the protection and advocacy services commission.

(17) The resident has the right to relocate prior to the expiration of the two (2) day notice.

(18) Prior to any interfacility or involuntary intrafacility relocation, the facility shall prepare a relocation plan to

prepare the resident for relocation and to provide continuity of care. In nonemergency relocations, the planning process shall include a relocation planning conference to which the resident, his or her legal representative, family members, and physician shall be invited. The planning conference may be waived by the resident.

(19) At the planning conference the resident's medical, psychosocial, and social needs with respect to the relocation shall be considered and a plan devised to meet these needs.

(20) The facility shall provide reasonable assistance to the resident to carry out the relocation plan.

(21) The facility must provide sufficient preparation and orientation to residents to ensure safe and orderly transfer or discharge from the facility.

(22) If the relocation plan is disputed, a meeting shall be held prior to the relocation with the administrator or his or her designee, the resident, and the resident's legal representative. An interested family member, if known, shall be invited. The purpose of the meeting shall be to discuss possible alternatives to the proposed relocation plan.

(23) A written report of the content of the discussion at the meeting and the results of the meeting shall be reviewed by the administrator or his or her designee, the resident, the resident's legal representative, and an interested family member, if known, each of whom may make written comments on the report.

(24) The written report of the meeting shall be included in the resident's permanent record.

~~(j) Residents have the right to exercise their rights as residents and citizens: Residents may, throughout the period of their stay, voice grievances to the facility staff or to an outside representative of their choice, recommend changes in policy and procedure, and receive reasonable responses to their requests without fear of reprisal or interference. The address and telephone number of:~~

- ~~(1) the department;~~
- ~~(2) the office of the secretary of family and social services;~~
- ~~(3) the ombudsman designated by the division of disability, aging, and rehabilitative services;~~
- ~~(4) the area agency on aging;~~
- ~~(5) the local mental health center; and~~
- ~~(6) the protection and advocacy services commission;~~

~~shall be displayed in a prominent place in the facility. A telephone accessible to the residents shall be provided for emergency and reasonable personal use.~~

**(s) Residents have the right to have reasonable access to the use of the telephone for local or toll free calls for emergency and personal use where calls can be made without being overheard.**

~~(k) (t) Residents have the right to manage their personal affairs and funds. Or~~ **When the facility manages these services, a resident may, by written request, allow the facility to execute all or part of their financial affairs. Management**

## Proposed Rules

does not include the safekeeping of personal items. If the facility agrees to ~~handle~~ manage the resident's funds, the resident facility must be provided with:

- (1) **provide the resident with** a quarterly accounting of all financial affairs handled by the facility;
- (2) **provide the resident, upon the resident's request, with** reasonable access, during normal business hours, to the written records of all financial transactions involving the individual resident's funds; ~~upon request;~~
- (3) **provide for a** separation of resident and facility funds; ~~and~~
- (4) return to the resident ~~no later than fifteen (15) calendar days,~~ upon written request **and within no later than fifteen (15) calendar days,** all or any part of the resident's funds given the facility for safekeeping;
- (5) **deposit, unless otherwise required by federal law, any resident's personal funds in excess of one hundred dollars (\$100) in an interest-bearing account (or accounts) that is separate from any of the facility's operating accounts and that credits all interest earned on the resident's funds to his or her account. (In pooled accounts, there must be a separate accounting for each resident's share.);**
- (6) **maintain resident's personal funds that do not exceed one hundred dollars (\$100) in a noninterest-bearing account, interest-bearing account, or petty cash fund;**
- (7) **establish and maintain a system that assures a full, complete, and separate accounting, according to generally accepted accounting principles, of each resident's personal funds entrusted to the facility on the resident's behalf;**
- (8) **provide the resident or the resident's legal representative with reasonable access during normal business hours to the funds in the resident's account;**
- (9) **provide the resident or the resident's legal representative upon request with reasonable access during normal business hours to the written records of all financial transactions involving the individual resident's funds;**
- (10) **provide to the resident or his or her legal representative a quarterly statement of the individual financial record and provide to the resident or his or her legal representative a statement of the individual financial record upon the request of the resident or the resident's legal representative; and**
- (11) **convey, within thirty (30) days of the death of a resident who has personal funds deposited with the facility, the resident's funds and a final accounting of those funds to the individual or probate jurisdiction administering the resident's estate.**

(+) (u) Residents have the right to be free from any physical and mental abuse (including sexual abuse); neglect, and restraint or chemical restraints imposed for purposes of discipline or convenience and not required to treat the resident's medical symptoms.

(v) Residents have the right to be free from sexual,

physical, mental abuse, corporal punishment, neglect, and involuntary seclusion.

(w) Residents have the right to be free from verbal abuse.

(~~m~~) (x) Residents have the right to confidentiality of all personal and clinical records. Information from these sources shall not be released without the resident's consent, except ~~upon transfer when the resident is transferred~~ to another health facility, when required by law, or under a third party payment contract. The resident's records shall be made immediately available to the resident for inspection, and the resident may receive a copy within a reasonable time, **five (5) working days,** at the resident's expense.

(~~n~~) (y) Residents have the right to be treated as individuals with consideration and respect for their privacy. Privacy shall be afforded for at least the following:

- (1) Bathing.
- (2) Personal care.
- (3) Physical examinations and treatments.
- (4) Visitations.

(~~o~~) (z) Residents have the right ~~not to be required~~

(1) **refuse to perform services for the facility; unless such work is medically indicated and included in the therapeutic treatment plan as prescribed by the physician; or unless the resident so requests and the attending physician approves, in writing;**

(2) **perform services for the facility, if he or she chooses, when:**

- (A) **the facility has documented the need of desire for work in the service plan;**
- (B) **the service plan specifies the nature of the duties performed and whether the duties are voluntary or paid;**
- (C) **compensation for paid duties is at or above the prevailing rates; and**
- (D) **the resident agrees to the work arrangement described in the service plan.**

(aa) Residents have the right to privacy in written communications, including the right to:

- (1) **send and promptly receive mail that is unopened unless the administrator has been instructed otherwise in writing by the resident; and**
- (2) **have access to stationery, postage, and writing implements at the resident's own expense.**

(bb) Residents have the right and the facility must provide immediate access to any resident by:

- (1) **individuals representing state or federal agencies;**
- (2) **any authorized representative of the state;**
- (3) **the resident's individual physician;**
- (4) **the state and area long term care ombudsman;**

- (5) the agency responsible for the protection and advocacy system for developmentally disabled individuals;
- (6) the agency responsible for the protection and advocacy system for mentally ill individuals;
- (7) immediate family or other relatives of the resident, subject to the resident's right to deny or withdraw consent at any time;
- (8) the resident's legal representative or spiritual advisor subject to the resident's right to deny or withdraw consent at any time; and
- (9) others who are visiting with the consent of the resident subject to reasonable restrictions and the resident's right to deny or withdraw consent at any time.

~~(p)~~ **(cc)** Residents have the right to choose with whom they associate. The facility shall provide reasonable visiting hours, which should include at least ~~nine~~ **(9) twelve (12)** hours a day, and the hours shall be ~~posted in a prominent place in the facility and~~ made available to each resident. Policies shall also provide for emergency visitation at other ~~than~~ **posted** hours. The facility shall not restrict visits from the resident's legal representative ~~sponsor, surrogate advocate, or spiritual advisor, except at the request of the resident. or sponsor. The resident's mail, either incoming or outgoing, shall remain intact and unopened unless the administrator has been instructed otherwise in writing by the resident.~~

**(dd)** The facility shall provide reasonable access to any resident, consistent with facility policy, by any entity or individual that provides health, social, legal, and other services to any resident, subject to the resident's right to deny or withdraw consent at any time.

**(ee)** The facility shall allow representatives of the state ombudsman to examine a resident's clinical records with the permission of the resident or the resident's legal representative, and consistent with state law.

~~(q)~~ **(ff)** Residents have the right to participate in social, religious, community services, and other activities of their choice that do not interfere with the rights of other residents at the facility.

~~(r)~~ **(gg)** Residents have the right to individual expression through retention of personal clothing and belongings as space permits unless to do so would infringe upon the rights of others or would create a health or safety hazard.

**(hh)** The facility shall exercise reasonable care for the protection of residents' property from loss and theft. The administrator or his or her designee is responsible for investigating reports of lost or stolen resident property **and that the results of the investigation are reported to the resident.**

**(ii)** If the resident's personal laundry is laundered by the facility, the facility shall identify these items in a suitable manner, at the resident's request.

**(jj)** Residents may use facility equipment, such as washing machines, if permitted by facility.

~~(s)~~ **(kk)** For purposes of IC 16-28-5-1, a breach of: subsection (a); (b); (c); (d); (e); (f); (g); (h); (i); (j); (k); (l); (m); (n); (o); (p); (q); or (r) is a deficiency:

- (1) subsection (u) or (v) is an offense;
- (2) subsection (b), (c), (d), (j), (k), (n), (o)(4), (r), (w), (x), (y), (z), (aa), (bb), or (dd) is a deficiency;
- (3) subsection (a), (e), (f), (g), (h), (i), (l), (o)(1), (o)(2), (o)(3), (p), (q), (s), (t), (cc), (ee), (ff), (gg), (hh), or (ii) is a noncompliance; and
- (4) subsection (m) or (jj) is a nonconformance.

*(Indiana State Department of Health; 410 IAC 16.2-5-1.2; filed Jan 10, 1997, 4:00 p.m.: 20 IR 1562, eff Apr 1, 1997; errata filed Apr 10, 1997, 12:15 p.m.: 20 IR 2415; readopted filed Jul 11, 2001, 2:23 p.m.: 24 IR 4234)*

SECTION 5. 410 IAC 16.2-5-1.3 IS AMENDED TO READ AS FOLLOWS:

**410 IAC 16.2-5-1.3 Administration and management**

Authority: IC 16-28-1-7; IC 16-28-1-12

Affected: IC 16-28-5-1; IC 25-19-1

Sec. 1.3. (a) The licensee is responsible for compliance with all applicable laws. The licensee has full authority and responsibility for the organization, management, operation, and control of the licensed facility. The delegation of any authority by the licensee does not diminish the responsibilities of the licensee.

(b) The licensee shall **employ provide** the number of staff as required to carry out all the functions of the facility, including the following:

- (1) Initial orientation of all employees.
- (2) A continuing in-service education and training program for all employees.
- (3) Provision of supervision for all employees.

(c) The licensee shall appoint **an administrator licensed pursuant to IC 25-19-1** and delegate to ~~an~~ **that** administrator ~~licensed pursuant to IC 25-19-1~~ the authority to organize and implement the day-to-day operations of the facility. The licensee, if a licensed administrator, may act as the administrator of the facility.

~~(d) If a facility offers services in addition to those provided to its long term care residents, the administrator is responsible for assuring that such additional services do not adversely affect the care provided to its residents.~~

~~(e)~~ **(d)** The licensee shall notify the director within three (3) working days of a vacancy in the administrator's position. The licensee shall also notify the director of the name and license number of the replacement administrator.

## Proposed Rules

(f) (e) An administrator shall be employed to work in each licensed health facility. For purposes of this subsection, an individual can only be employed as an administrator in one (1) health facility or one (1) hospital based long term care unit at a time.

(g) (f) In the administrator's absence, an individual shall be authorized, in writing, to act on the administrator's behalf.

(h) (g) The administrator is responsible for the overall management of the facility. ~~but shall not function as a departmental supervisor, for example, director of nursing or food service supervisor, during the same hours.~~ The responsibilities of the administrator shall include, but are not limited to, the following:

(1) ~~Immediately Informing the division by telephone, followed by written notice within twenty-four (24) hours of becoming aware of an unusual occurrences occurrence that directly threaten threatens the welfare, safety, or health of the residents, including, a resident. Notice of unusual occurrence may be made by telephone, followed by a written report, or by a written report only that is faxed or sent by electronic mail to the division within the twenty-four (24) hour time period. Unusual occurrences include, but are not limited to, any epidemic outbreaks, poisonings, fires, or major accidents. If the division cannot be reached, such as on holidays or weekends, a call shall be made to the emergency telephone number ((317) 383-6144) of published by the division.~~

(2) Promptly arranging for ~~or assisting with the provision of~~ medical, dental, podiatry, or nursing care or other health care services as ~~prescribed requested~~ by the ~~attending physician; resident or resident's legal representative.~~

(3) Obtaining director approval prior to the admission of an individual under eighteen (18) years of age to an adult facility.

(4) Ensuring ~~that~~ the facility maintains, on the premises, ~~time schedules and~~ an accurate record of actual time worked that indicates the employee's full name and the dates and hours worked during the past twelve (12) months. ~~This information shall be furnished to the division staff upon request.~~

(5) ~~Once furnished a copy by the division, maintaining a copy of this article, and making it available to all personnel, the residents, sponsors, or surrogates. Posting the results of the most recent annual survey of the facility conducted by state surveyors and any plan of correction in effect with respect to the facility, and any subsequent surveys. The results must be available for examination in the facility in a place readily accessible to residents, and a notice posted of their availability.~~

(6) ~~Once furnished a copy by the division, informing affected staff of any amendments to this article no later than the effective date of the amendments.~~

(7) (6) Maintaining reports of surveys conducted by the division in each facility for a period of two (2) years and

making the reports available for inspection to any member of the public upon request.

(i) ~~Each facility, except a facility that cares for children or an intermediate care facility for the mentally retarded, shall encourage all employees serving residents or the public to wear name and title identification.~~

(j) ~~Each~~ (h) The facility shall establish and implement a written policy manual to ensure that resident care and facility objectives are attained, to include the range of services offered, resident rights, personnel administration, and facility operations. **Such policies shall be made available to residents upon request.**

(k) The licensee shall approve the policy manual, and subsequent revisions, in writing. The policy manual shall be reviewed and dated at least annually.

(l) The policies shall be maintained in a manual accessible to employees and made available upon request to residents, the division, the legal representative of a resident, and the public. Management/ownership confidential directives are not required to be included in the policy manual; however, the policy manual must include all of the facility's operational policies.

(m) (i) The policy manual shall contain **facility must maintain** a written fire and disaster preparedness plan to assure continuity of care of residents in cases of emergency as follows:

(1) ~~Facilities caring for children shall have a written plan outlining the staff procedures, including isolation and evacuation, in case of an outbreak of childhood diseases.~~

(2) (1) Fire exit drills in facilities shall include the transmission of a fire alarm signal and simulation of emergency fire conditions, except that the movement of ~~infirm or bedridden patients nonambulatory residents~~ to safe areas or to the exterior of the building is not required. Drills shall be conducted quarterly on each shift to familiarize all facility personnel with signals and emergency action required under varied conditions. At least twelve (12) drills shall be held every year. When drills are conducted between 9 p.m. and 6 a.m., a coded announcement may be used instead of audible alarms.

(3) (2) At least every six (6) months, a facility shall attempt to hold the fire and disaster drill in conjunction with the local fire department. A record of all training and drills shall be documented with the names and signatures of the personnel present.

(n) (j) If professional or diagnostic services are to be provided to the facility by an outside resource, either individual or institutional, an arrangement shall be developed between the licensee and the outside resource for the provision of the services. If a written agreement is used, it shall specify the responsibilities of both the facility and the outside resource, the qualifications of the outside resource staff, a description of the



type of services to be provided, including action taken and reports of findings, and the duration of the agreement.

(o) Each (k) The facility shall conspicuously post the license or a true copy thereof within the facility in a location accessible to public view.

(p) Each facility shall submit an annual statistical report to the department.

(q) The facility shall have a written and signed transfer agreement with one (1) or more hospitals within reasonable proximity of the facility to make feasible the transfer of residents and applicable records as follows:

(1) A facility that has been unable to establish a transfer agreement with the hospitals in the community or service area; after documented attempts to do so; is considered to have an agreement in effect.

(2) The written transfer agreement shall be as follows:

(A) Be in writing and shall be signed by persons authorized to execute the agreement on behalf of the institutions. Each institution shall maintain a copy of the agreement.

(B) Ensure the change of medical and other information necessary or useful in the care and treatment of residents transferred between the institutions or in determining whether such residents can be adequately cared for.

(C) Specify the responsibilities assumed by both the discharging and receiving institutions for:

(i) prompt notification of the impending transfer of the resident;

(ii) agreement by the receiving institution to admit the resident;

(iii) arranging appropriate transportation and care of the resident during transfer; and

(iv) the transfer of personal effects, particularly money and valuables and of information related to such items.

(D) Specify restrictions with respect to the types of services available and/or the types of residents or health conditions that will not be accepted by the hospital or the facility, including any other criteria relating to the transfer of residents.

(r) (1) For purposes of IC 16-28-5-1, a breach of:

(1) subsection (a); (d); or (h) is a deficiency;

(2) subsection (b); (c); (f); (g); (j); (m); or (q) is a noncompliance; and

(3) subsection (e); (i); (k); (l); (n); (o); or (p) is a nonconformance

(1) subsection (a) or (g) is a deficiency;

(2) subsection (b), (c), (d), (e), (f), (h), (i), or (j) is a noncompliance; and

(3) subsection (k) is a nonconformance.

*(Indiana State Department of Health; 410 IAC 16.2-5-1.3; filed Jan 10, 1997, 4:00 p.m.: 20 IR 1565, eff Apr 1, 1997; errata filed Jan 10, 1997, 4:00 p.m.: 20 IR 1593; errata filed Apr 10,*

*1997, 12:15 p.m.: 20 IR 2415; readopted filed Jul 11, 2001, 2:23 p.m.: 24 IR 4234)*

SECTION 6. 410 IAC 16.2-5-1.4 IS AMENDED TO READ AS FOLLOWS:

**410 IAC 16.2-5-1.4 Personnel**

Authority: IC 16-28-1-7; IC 16-28-1-12

Affected: IC 16-28-5-1; IC 16-28-13-3

Sec. 1.4. (a) Each facility shall have specific procedures written and implemented for the screening of prospective employees. Specific **Appropriate** inquiries shall be made for prospective employees. The facility shall have a personnel policy that considers references and any convictions in accordance with IC 16-28-13-3.

(b) Each facility shall maintain a staffing pattern for all departments that shall be made available to the division as follows:

(1) The minimum staffing ratios required by this article shall be maintained at all times, including relief periods, vacation periods, and holidays.

(2) Each employee on duty shall be dressed in accordance with facility policy; awake; and mentally and physically capable of giving care as required and responding appropriately in an emergency.

(3) Each residential care facility shall have at least one (1) employee on duty at all times.

**Staff shall be sufficient in number, qualifications and training in accordance with applicable state laws and rules to meet the twenty-four (24) hour scheduled and unscheduled needs of the residents and services provided. The number, qualifications and training of staff shall depend on skills required to provide for the specific needs of the residents. A minimum of one (1) awake staff person, with current CPR and first aid certificates, shall be on-site at all times. If fifty (50) or more residents of the facility regularly receive residential nursing services and/or administration of medication, at least one (1) nursing staff person shall be on-site at all times. Residential facilities with over one hundred (100) residents regularly receiving residential nursing services and/or administration of medication shall have at least one (1) additional employee nursing staff person awake and on duty at all times for every additional fifty (50) residents or major fraction thereof. In a facility having both comprehensive and residential distinct parts, the employee or employees assigned to the residential distinct part may be stationed and may work in the comprehensive distinct part during the second and third shifts. Residential employees assigned to the comprehensive distinct part must be readily available to the residents of the residential distinct part. However, such employees' time does not count toward the staffing requirements of the comprehensive distinct part.**

(4) Personnel shall be assigned only those duties for which they are trained to perform. Employee duties shall conform with written job descriptions.

## Proposed Rules

(c) Any unlicensed employee providing more than limited assistance with the activities of daily living must be either a certified nurse aide or a home health aide. Existing facilities that are not licensed on the date of adoption of this rule and that seek licensure within one (1) year of adoption of this rule, have two (2) months in which to ensure that all employees in this category are either a certified nurse aide or a home health aide.

(e) (d) Prior to working independently, each employee shall be given an orientation to the facility by the supervisor (or his or her designee) of the department in which the employee will work. Orientation of nursing staff shall be supervised by the director of nursing or a licensed designee. Orientation of all employees shall include the following:

(1) Instructions on the needs of the specialized populations served in the facility (aged, developmentally disabled, mentally ill, **dementia**, or children).

(2) A review of the facility's policy manual and applicable procedures, including:

(A) organization chart;

(B) personnel policies;

(C) appearance and grooming **policies for employees**; and

(D) residents' rights.

(3) Instruction in first aid, emergency procedures, and fire and disaster preparedness, including evacuation procedures.

~~(4) A detailed review of the appropriate job description, including a demonstration of equipment and procedures required of the specific position to which the employee will be assigned.~~

~~(5) (4) Review of ethical considerations and confidentiality in resident care and records.~~

~~(6) (5) For direct care staff, personal introduction to, and instruction in, the particular needs of each resident to whom the employee will be providing care.~~

~~(7) (6) Documentation of the orientation in the employee's personnel record by the person supervising the orientation, and that the employee has demonstrated sufficient knowledge to properly carry out the job.~~

(d) Each nurse aide without one (1) year of experience in a health care setting who is hired after January 1, 1985, to work in a facility shall have successfully completed a nurse aide training program approved by the division or shall enroll in the first available approved training program scheduled to commence within sixty (60) days of the date of the nurse aide's employment. The program may be established by the facility or by an organization or institution. The training program shall consist of at least the following:

(1) Thirty (30) hours of classroom instruction within one hundred eighty (180) days of employment. At least fifteen (15) of these hours shall be given before the nurse aide is assigned direct resident care duties. The instruction shall include orientation to the:

(A) facility;

(B) facility policies;

(C) employee's duties;

(D) basic nursing skills;

(E) clinical practice;

(F) resident safety and rights; and

(G) social and psychological problems of residents.

The thirty (30) hours may not be counted toward a facility's required staffing:

(2) Seventy-five (75) hours of supervised training. These hours shall consist of normal employment as a nurse aide under the supervision of a licensed nurse. The seventy-five (75) hours shall be counted toward the facility's required staffing:

(e) There shall be an organized ongoing in-service education and training program planned in advance for all personnel in all departments **This at least annually**. Training shall include, but is not limited to, **resident's rights**, prevention and control of infection, fire prevention, safety, and accident prevention, and the needs of specialized populations served, **that is, the aged, developmentally disabled, mentally ill, or children, medication administration, and nursing care, when appropriate**, as follows:

(1) In-service training programs shall contain means to assess learning by participants. These may include testing such as self-graded, before-and-after tests, clinical practice sessions under close supervision, or instructor assessment.

(2) In-service programs shall be designed to enable the staff to meet the needs of residents:

(3) (1) The frequency and content of in-service education and training programs shall be in accordance with the skills and knowledge of the facility personnel. **For nursing personnel, this shall include at least eight (8) hours of in-service per calendar year and four (4) hours of in-service per calendar year for nonnursing personnel.**

(4) Monthly in-service training shall be conducted for the nursing staff. In addition, for personnel administering medications, no less than eight (8) programs on medication administration shall be offered per year.

(5) Annual in-service training shall be conducted for all nursing personnel on supportive therapy measures, that is:

(A) range of motion;

(B) transfers;

(C) positioning;

(D) supportive use of hearing aids; or

(E) self-help feeding devices.

(6) Programs shall be offered at least quarterly for all departments:

(7) The administrator may approve attendance at outside workshops and continuing education programs that are related to that individual's responsibilities in the facility. Documented attendance at these workshops and programs meets the requirements for in-service training.

(2) In addition to the above required in-service hours in facilities with distinct dementia units, staff who have contact with such residents shall have a minimum of six

**(6) hours of dementia-specific training within six (6) months, and three (3) hours annually thereafter to meet the needs/preferences of cognitively impaired residents effectively and to gain understanding of the current standards of care for residents with dementia.**

~~(8)~~ **(3)** In-service records shall be maintained and shall indicate the following:

- (A) Time, date, and location.
- (B) Name of instructor.
- (C) Title of instructor.
- (D) Name of participants.
- (E) Program content of in-service.

The employee will acknowledge attendance by written signature.

(f) A ~~physical examination health screen~~ shall be required for each employee of a facility ~~at the time of employment~~. **prior to resident contact.** The ~~examination screen~~ shall include a tuberculin skin test, using the Mantoux method (5 TU, PPD), unless a previously positive reaction can be documented. The result shall be recorded in millimeters of induration with the date given, date read, and by whom administered. The facility must assure the following:

(1) At the time of employment, **or within one (1) month prior to employment**, and at least annually thereafter, employees and nonpaid personnel of facilities shall be screened for tuberculosis. **The first tuberculin skin test must be read prior to the employee starting work.** For health care workers who have not had a documented negative tuberculin skin test result during the preceding twelve (12) months, the baseline tuberculin skin testing should employ the two-step method. If the first step is negative, a second test should be performed one (1) to three (3) weeks after the first step. The frequency of repeat testing will depend on the risk of infection with tuberculosis.

(2) All employees who have a positive reaction to the skin test shall be required to have a chest x-ray and other physical and laboratory examinations in order to complete a diagnosis.

(3) The facility shall maintain a health record of each employee that includes

- ~~(A) a report of the preemployment physical examination; and~~
- ~~(B) reports of all employment-related health examinations; screenings.~~

(4) An employee with symptoms or signs of active disease, (symptoms suggestive of active tuberculosis, including, but not limited to, cough, fever, night sweats, and weight loss) shall not be permitted to work until tuberculosis is ruled out.

**(g) The facility must prohibit employees with communicable disease or infected skin lesions from direct contact with residents or their food if direct contact will transmit the disease. An employee with signs and symptoms of communicable disease, including, but not limited to, an infected or draining skin lesion shall be handled according to a facility's policy regarding direct contact with residents, their**

**food, or resident care items until the condition is resolved. Persons with suspected or proven active tuberculosis, will not be permitted to work until determined to be noninfectious and documentation is provided for the employee record.**

~~(g)~~ **(h)** The facility shall maintain current and accurate personnel records for all employees. The personnel records for all employees shall include the following:

- (1) Name and address of employee.
- (2) Social Security number.
- (3) Date of beginning employment.
- (4) Past employment, experience, and education, if applicable.
- (5) Professional licensure or registration number, if applicable.
- (6) Position in the facility and job description.
- (7) Documentation of orientation to the facility, **including residents' rights**, and to the specific job skills.
- (8) Signed acknowledgment of orientation to **resident residents'** rights.
- (9) Performance evaluations in accordance with facility policy.
- (10) Date and reason for separation.

~~(h)~~ **(i)** The employee personnel record shall be retained for at least three (3) years following termination or separation of the employee from employment.

- ~~(i)~~ **(j)** For purposes of IC 16-28-5-1, a breach of:
  - ~~(1) subsection (a); (b); (c); (d); (e); or (f) is a noncompliance; and~~
  - ~~(2) subsection (g) or (h) is a nonconformance.~~
  - (1) subsection (b), (c), or (g) is a deficiency;**
  - (2) subsection (a), (d), (e), or (f) is a noncompliance; and**
  - (3) subsection (h) or (i) is a nonconformance.**

*(Indiana State Department of Health; 410 IAC 16.2-5-1.4; filed Jan 10, 1997, 4:00 p.m.: 20 IR 1567, eff Apr 1, 1997; errata filed Apr 10, 1997, 12:15 p.m.: 20 IR 2415; readopted filed Jul 11, 2001, 2:23 p.m.: 24 IR 4234)*

SECTION 7. 410 IAC 16.2-5-1.5 IS AMENDED TO READ AS FOLLOWS:

**410 IAC 16.2-5-1.5 Sanitation and safety standards**

Authority: IC 16-28-1-7; IC 16-28-1-12  
Affected: IC 16-28-5-1

Sec. 1.5. (a) ~~Each~~ **The** facility shall be clean, orderly, and in a state of good repair, both inside and out, and shall provide reasonable comfort for all residents.

(b) ~~Each~~ **The** facility shall maintain equipment and supplies in a safe and operational condition and in sufficient quantity to meet the needs of the residents.

(c) ~~Each~~ **The** facility shall not have more residents ~~or beds set up for use~~ than the number for which it is licensed, except in the case of emergency when temporary permission may be granted by the director.

## Proposed Rules

(d) Each facility shall store inactive clinical records in a safe and accessible manner. The storage facilities shall provide protection from vermin and unauthorized use.

(e) Each (d) The facility shall comply with fire and safety standards, including the applicable rules of the state fire prevention and building safety commission (675 IAC) where applicable to health facilities.

(f) Each (e) The facility shall maintain buildings, grounds, and equipment in a clean condition, in good repair, and free of hazards that may adversely affect the health and welfare of the residents or the public as follows:

(1) Each facility shall establish **and implement** a written program for maintenance to ensure the continued upkeep of the facility.

(2) The electrical system, including appliances, cords, switches, alternate power sources, fire alarm and detection systems, **and emergency communication and signaling systems**, shall be maintained to guarantee safe functioning and compliance with state electrical codes.

(3) All plumbing shall function properly and comply with state plumbing codes.

(4) At least yearly, heating and ventilating systems shall be inspected.

(g) Each facility shall routinely clean articles and surfaces as follows:

(1) Cleaning schedules and procedures shall be accessible to and followed by employees and shall indicate the areas of the facility that shall be cleaned daily, weekly, and monthly.

(2) Housekeeping personnel shall utilize accepted practices and procedures to keep the facility free from offensive odors and the accumulation of dust, rubbish, dirt, and hazards, including the following:

(A) Floors in resident areas shall be maintained in a clean condition.

(B) Toilet and bathing areas shall be thoroughly cleaned at least daily and sanitized as needed.

(C) All furniture, bedding, and equipment shall be cleaned as often as necessary to maintain a sanitary environment, but at least monthly and before use by another resident.

(D) Deodorizers shall not be used to cover up odors caused by unsanitary conditions.

(E) Janitor's closets, service sinks, and storage areas shall be cleaned and maintained to meet the needs of the facility.

(F) Storage areas, attics, or cellars shall be kept safe and free from accumulation of unserviceable articles.

(G) Cleaning supplies and equipment shall be stored in a safe and secure manner. Residents shall not have access to any cleaning agents, bleaches, or other poisonous or flammable materials.

(H) Mop heads shall be removable and changed as often as necessary to assure that the mop head in use is clean and free of odors.

(I) Polishes used for floors shall provide a nonslip finish.

(3) Employees engaged in housekeeping or laundry functions shall not be simultaneously involved in the preparation of food.

(4) A person qualified by experience and training shall be in charge of the housekeeping department.

(5) If the facility has a contract with an outside resource for housekeeping services, the outside resource shall meet the requirements of this subsection.

(h) Each (f) The facility shall have a pest control program in operation in compliance with ~~410 IAC 7-15.1~~ **410 IAC 7-20**.

(i) (g) Each facility shall have a policy concerning pets. Pets may be permitted in a facility but shall not be allowed to create a nuisance or safety hazard.

(j) (h) Any pet housed in a facility shall have periodic veterinary examinations and required immunizations.

(k) Each facility shall handle, store, process, and transport clean linen in a safe and sanitary manner as follows:

(1) Clean linen shall be stored, handled, and transported in a way that prevents contamination. Personnel handling clean or soiled linen shall hold it in such a manner to prevent contamination of the linen or the employee.

(2) Clean linen from a commercial laundry shall be delivered to a designated clean area in a manner that prevents contamination.

(3) Linens shall be maintained in good repair.

(4) The supply of clean linens, washcloths, and towels shall be sufficient to meet the needs of each resident. The use of common towels, washcloths, or toilet articles is prohibited.

(l) Each (i) The facility shall handle, store, process, and transport **clean and** soiled linen in a **safe and sanitary** manner that will prevent the spread of infection. as follows:

(1) Soiled linen shall be sorted by methods affording protection from contamination.

(2) Soiled linens shall be stored and transported in a closed container that does not permit contamination of corridors and precludes contamination of clean linen.

(3) When laundry chutes are used to transport soiled linens, the chutes shall be maintained in a clean and sanitary state.

(m) Each facility shall handle, store, process, and transport resident clothing in a clean and orderly manner. If the resident's clothing is laundered by the facility, the facility shall identify the clothing in a suitable manner. The facility is only responsible for marking that clothing that is recorded on the resident's inventory sheet.

(n) Each (j) The facility shall observe safety precautions when oxygen is stored or administered as follows: **in the facility**.

(1) Oxygen containers shall be suitably anchored to the bed, floor, wall, or carrier to prevent the containers from tipping over.

(2) Oxygen containers when not in use shall be stored in an unheated room vented to the outside or in an outside secured area. Building code standards shall apply.

(3) "Oxygen-No Smoking" signs shall be posted on the outside of the door and the inside of the door of a resident room in which oxygen is being administered.

**Residents on oxygen shall be instructed in safety measures concerning storage and administration of oxygen.**

(r) Each (k) The facility shall keep all kitchens, kitchen areas, **common dining areas**, equipment, and utensils clean, free from litter and rubbish, and maintained in good repair in accordance with ~~410 IAC 7-15.1~~ **410 IAC 7-20**.

(p) Each (l) The facility shall have an effective garbage and waste disposal program in accordance with ~~410 IAC 7-15.1~~ **410 IAC 7-20**. Provision shall be made for the safe and sanitary disposal of solid waste, including dressings, needles, syringes, and similar items.

(q) Each (m) The facility's food supplies shall meet the standards of ~~410 IAC 7-15.1~~ as follows:

(1) At least a twenty-four (24) hour supply of perishable food and a three (3) day supply of staple food shall be maintained on the premises to meet the planned menu.

(2) The three (3) day supply of staple foods shall include a variety of canned or processed foods from each of the four (4) basic food groups for serving meals to the residents for a minimum of three (3) days in the event of an emergency or disaster.

(3) Invoices for the preceding three (3) months, showing the amount and kind of food purchased, shall be made available to division staff upon request.

**410 IAC 7-20.**

(n) The facility shall develop, adopt, and implement written policies and procedures on cleaning, disinfecting, and sterilizing equipment used by more than one (1) person in a common area.

(r) (o) For purposes of IC 16-28-5-1, a breach of:

(1) subsection (e) or (n) is a deficiency;

(2) subsection (a), (b), (c), (f), (g), (h), (j), (k), (l), (m), (o), (p), or (q) is a noncompliance; and

(3) subsection (d) or (i) is a nonconformance.

(1) subsection (a), (b), (d), (e), (f), (i), (j), (k), (l), (m), or (n) is a deficiency;

(2) subsection (g), or (h) is a noncompliance; and

(3) subsection (c) is a nonconformance.

*(Indiana State Department of Health; 410 IAC 16.2-5-1.5; filed Jan 10, 1997, 4:00 p.m.: 20 IR 1569, eff Apr 1, 1997; readopted filed Jul 11, 2001, 2:23 p.m.: 24 IR 4234)*

SECTION 8. 410 IAC 16.2-5-1.6 IS AMENDED TO READ AS FOLLOWS:

**410 IAC 16.2-5-1.6 Physical plant standards**

Authority: IC 16-28-1-7; IC 16-28-1-12

Affected: IC 16-28-2; IC 16-28-5-1

Sec. 1.6. (a) This section applies to residential facilities licensed under IC 16-28-2.

(b) Each (a) The facility shall make provisions for the handicapped as required by state or federal codes.

(c) Each (b) The facility shall have adequate plumbing, heating, and ventilating systems as governed by applicable rules of the fire prevention and building safety commission (675 IAC). Plumbing, heating, and ventilating systems shall be maintained in normal operating condition and utilized as necessary to provide comfortable temperatures in all areas.

(d) After July 1, 1987, (c) Each facility shall have an adequate air conditioning system, as governed by applicable rules of the fire prevention and building safety commission (675 IAC). The air conditioning system shall be maintained in normal operating condition and utilized as necessary to provide comfortable temperatures in all resident and public areas.

(e) Each (d) The facility shall use an approved public water supply if available. Water service shall be adequate, brought into the building and installed in compliance with state and local requirements, and free of cross connections. **be supplied with safe, potable water, under pressure, from a source approved by the Indiana department of environmental management.** If a private water supply is used, the facility shall comply with appropriate laws and rules.

(f) (e) Sewage shall be discharged into an approved a public sewerage system **in accordance with the laws and rules of the Indiana water pollution control board**, where a system is available. Otherwise, sewage shall be collected, treated, and disposed of in an **independent approved on-site wastewater system that complies with appropriate laws and rules: in accordance with 410 IAC 6-10.**

(g) Each (f) The facility shall have, for each room used for dining, living, or sleeping purposes, light and ventilation by means of outside windows with an area equal to one-tenth ( $1/10$ ) of the total floor area of such rooms. ~~up to~~

(g) The following standards apply to resident rooms:

(1) Each room shall have at least eighty (80) square feet per bed for rooms occupied by more than one (2) person and one hundred (100) square feet for single occupancy.

(2) A facility initially licensed prior to January 1, 1964, must provide not less than sixty (60) square feet per bed in multiple occupancy rooms.

(3) A facility initially licensed after January 1, 1964, must have at least seventy (70) square feet of usable floor area for each bed.

## Proposed Rules

(4) Any facility that provides an increase in bed capacity, with plans approved after December 19, 1977, must provide eighty (80) square feet of usable floor area per bed.

(5) For facilities and additions to facilities for which construction plans are submitted for approval after July 1, 1984, resident rooms shall not contain more than four (4) residents' beds per room.

(h) Each The facility shall have natural lighting augmented by artificial illumination, when necessary, to provide light intensity and to avoid glare and reflective surfaces that produce discomfort and as indicated in the following table:

Minimum Average Area	Foot-Candles
Corridors and interior ramp	15
Stairways and landing	20
Recreation area	40
Dining area	20
Resident care room	20
Nurses' station	40
Nurses' desk for charts and records	60
Medicine cabinet	75
Utility room	15
Janitor's closet	15
Reading and bed lamps	20
Toilet and bathing facilities	20
Food preparation surfaces and utensil washing facilities	70

(i) Each The facility shall house residents only in areas approved by the director for resident housing and given a fire clearance by the state fire marshal. Each The facility must comply with the following: shall:

(1) Five (5) resident beds per room shall be the maximum bedroom capacity.

(2) A facility initially licensed prior to January 1, 1964, must provide not less than sixty (60) square feet per bed in multiple occupancy rooms. A facility initially licensed after January 1, 1964, must have at least seventy (70) square feet of usable floor area for each bed. Any facility that provides an increase in bed capacity, with plans approved after December 19, 1977, must provide eighty (80) square feet of usable floor area per bed.

(3) Any room utilized for single occupancy must be at least eight (8) feet by ten (10) feet in size with a minimum ceiling height of eight (8) feet. A new facility, plans for which were approved after December 19, 1977, must contain a minimum of one hundred (100) square feet of usable floor space per room for single occupancy.

(4) Each bed shall have an access aisle not less than three (3) feet wide leading to it. Bed arrangement in a multi-occupancy room shall provide at least three (3) feet between beds. If an access aisle is used as a means of egress, it shall not be less than four (4) feet wide.

(5) Basement rooms shall not be used to house residents. For

new construction, plans for which were approved after December 19, 1977, rooms below grade level may be used for resident occupancy if the floor of such a room is not more than three (3) feet below ground level.

(6) The resident shall have the following:

(A) A bed:

(i) of proper size and height for the convenience of the resident;

(ii) with a clean and comfortable mattress; and

(iii) with bedding appropriate to the weather, climate, and the comfort of the resident.

A resident may choose his or her own furniture in compliance with the facility's policy manual.

(B) The bed linen, consisting of at least two (2) sheets; a pillowcase for each pillow; and a mattress pad; if required; shall be changed as necessary but not less than once a week.

(C) A blanket and/or bedspread shall be provided and shall be changed as necessary; although a bedspread is not required for a bedfast resident.

(D) Additional clean pillows shall be available for the positioning and comfort of residents.

(7) Each individual resident shall be provided with a complete bedside unit; however, the resident may choose not to use this bedside unit. This unit shall include, but is not limited to, the following:

(A) Bedside cabinet or table with hard surface and washable top.

(B) Private closet space.

(C) Cushioned comfortable chair.

(D) Reading or bed lamp.

(E) If the resident is bedfast, an adjustable over-the-bed table or other suitable device.

(8) Cubicle curtains or screens are not required in a licensed residential facility or in the residential distinct part of a facility; but cubicle curtains or screens must be provided if requested by a resident.

(9) Each facility shall provide an adequate method by which each resident may summon a staff person at any time.

(10) Each resident bedroom shall have a door that swings into the room and opens directly into the corridor or common living area.

(11) Each resident room shall be labeled with a raised or indented number (if approved prior to 1974) or letter, or combination of both.

(12) A resident shall not be housed in such a manner as to require passage through the room of another resident. Bedrooms shall not be used as a thoroughfare.

(13) Hallways and corridors shall not be used as sleeping rooms; use for other purposes may not violate fire codes.

(1) Have a floor at or above grade level. A facility whose plans were approved before the effective date of this rule may use rooms below ground level for resident occupancy if the floors are not more than three (3) feet below ground level.

## Proposed Rules

**(2) Provide each resident the following items upon request at the time of admission:**

- (A) A bed:**
  - (i) of appropriate size and height for the resident;**
  - (ii) with a clean and comfortable mattress; and**
  - (iii) with comfortable bedding appropriate to the temperature of the facility.**
- (B) A bedside cabinet or table with a hard surface and washable top.**
- (C) A cushioned comfortable chair.**
- (D) A bedside lamp.**
- (E) If the resident is bedfast, an adjustable over-the-bed table or other suitable device.**

**(3) Provide cubicle curtains or screens if requested by a resident in a shared room.**

**(4) Provide a method by which each resident may summon a staff person at any time.**

**(5) Equip each resident unit with a door that swings into the room and opens directly into the corridor or common living area.**

**(6) Not house a resident in such a manner as to require passage through the room of another resident. Bedrooms shall not be used as a thoroughfare.**

**(7) Individual closet space. For facilities and additions to facilities for which construction plans are submitted for approval after July 1, 1984, each resident room shall have clothing storage that includes a closet at least two (2) feet wide and two (2) feet deep, equipped with an easily opened door and a closet rod at least eighteen (18) inches long of adjustable height to provide access by residents in wheelchairs.**

**(j) Each facility shall have adequate toilet and bathing facilities as follows: The following standards apply to toilet, lavatory, and tub or showers:**

**(1) For facilities initially licensed after (effective date), each unit shall have a private toilet, lavatory, and tub or shower.**

**(2) For facilities for which plans were approved prior to April 1, 1997, the following criteria is applicable:**

**(+) (A) Bathing facilities for residents not served by bathing facilities in their rooms shall be provided as follows:**

Residents	Bathtubs or Showers
3 to 22	1
23 to 37	2
38 to 52	3
53 to 67	4
68 to 82	5
83 to 97	6

Portable bathing units may be substituted for one (1) or more of the permanent fixtures with prior approval of the director.

**(B) A central bathing tub shall be available.**

**(2) (C) Central bathing and toilet facilities shall be partitioned or curtained for privacy.**

**(3) (D) Toilets, bath, and shower compartments shall be separated from rooms by solid walls or partitions that extend from the floor to the ceiling.**

**(4) (E) Toilet facilities shall be provided as follows:**

Residents of the Same Sex	Toilets	Open-Front Lavatories
3 to 18	1	1
19 to 30	2	2
31 to 42	3	3
43 to 54	4	4
55 to 66	5	5
67 to 78	6	6

**(5) Rubber mats or other suitable safety measures shall be used in bathing facilities. Grab bars shall be installed within easy reach of the bather. Additional adaptive equipment for the multi-handicapped shall be provided as needed.**

**(6) Hot water temperature for all bathing and hand washing facilities shall be controlled by an automatic control valve. Water temperature at point of use must be maintained between one hundred degrees Fahrenheit (100°F) and one hundred twenty degrees Fahrenheit (120°F).**

**(7) The use of common towels, washcloths, or toilet articles is prohibited. Each facility shall maintain towels and washcloths in a satisfactory condition for each resident. Individual towel bars shall be provided in the resident's room.**

**(3) For facilities and additions to facilities for which construction plans are submitted for approval after July 1, 1984, at least one (1) toilet and lavatory shall be provided for each eight (8) residents as follows:**

**(A) Toilet rooms adjacent to resident bedrooms shall serve no more than two (2) resident rooms or more than eight (8) beds.**

**(B) The toilet room shall contain a toilet, lavatory, liquid soap, and disposable towel dispenser.**

**(C) Each resident shall have access to a toilet and lavatory without entering a common corridor area.**

**(D) For facility with common toilet facilities, at least one (1) toilet and one (1) lavatory for each gender on each floor utilized by residents.**

**(E) All bathing and shower rooms shall have mechanical ventilation.**

**(k) Each facility shall have a nurses' station in a convenient location in the nursing area. The nurses' station shall be equipped with the following:**

- (1) A desk.**
- (2) A chair.**
- (3) Records storage.**
- (4) A bookshelf for references.**
- (5) A bulletin board.**
- (6) A telephone for staff use.**

**Hot water temperature for all bathing and hand washing facilities shall be controlled by an automatic control valve. Water temperature at point of use must be maintained**

## Proposed Rules

between one hundred (100) degrees Fahrenheit and one hundred twenty (120) degrees Fahrenheit.

(l) Each **The** facility shall have a nourishment pantry or station for supplemental food service **separate from the resident's unit**.

(m) Ice shall be **readily available to residents** at all times in the facility.

(n) Each facility that administers medication to residents shall provide a medicine station for convenient and prompt twenty-four (24) hour distribution of medicine to residents as follows:

(1) The medicine preparation room shall be under the visual control of the nursing staff; be located adjacent to the nurses' station; and contain a well-lighted work counter; refrigerator; and locked storage for biochemicals and drugs.

(2) The medication preparation room shall have provision of water for hand washing and for medication administration.

(3) If medicine dispensing carts are used, a specific space shall be provided in the nurses' station; medication room; or an alcove or other space under direct control of the nursing staff. The nurses' station shall have provision for hand washing and water for medication purposes.

(4) The medicine room shall be clean; orderly; and used for the storage of drugs; nursing supplies; and first aid supplies.

(o) Each facility shall have equipment storage rooms for storage of equipment such as wheelchairs, walkers, or bed rails; so as not to interfere with the operation of any department or be inconvenient for residents or personnel. A hallway shall not be used for the storage of equipment.

(p) Each **(n) The** facility shall have living areas with sufficient space to accommodate the dining, activity, and lounge needs of the residents and to prevent the interference of one (1) function with another as follows:

(1) In a facility licensed prior to June 1970, the lounge area, which may also be used for dining, shall be a minimum of ten (10) square feet per bed.

(2) In a facility licensed since June 1970, total dining, activity, and lounge area shall be at least twenty (20) square feet per bed.

(3) **(1) Dining, lounge, and activity areas shall be:**

(A) readily accessible to wheelchair and ambulatory residents; and

(B) sufficient in size to accommodate necessary equipment and to permit unobstructed movement of wheelchairs, residents, and personnel responsible for assisting, instructing, or supervising residents.

(4) **(2) Dining tables of the appropriate height shall be provided to assure access to meals and comfort for residents seated in wheelchairs, geriatric chairs, and regular dining chairs. Facilities having continuing deficiencies in the service of resident meals directly attributable to inadequacies in the**

size of the dining room or dining areas shall submit a special plan of correction detailing how meal service will be changed to meet the residents' needs.

(5) **(3) A comfortably furnished resident living and lounge area shall be provided on each resident occupied floor of a multi-story building. This lounge may be furnished and maintained to accommodate activity and dining functions.**

(6) **The provision of an activity area shall be based on the level of care of the residents housed in the facility. The facility shall provide the following:**

(A) Equipment and supplies for independent and group activities and for residents having special needs.

(B) Space to store recreational equipment and supplies for the activities program within or convenient to the area.

(C) Locked storage for potentially dangerous items such as scissors, knives, razor blades, or toxic materials.

(D) In a facility for which plans were approved after December 19, 1977, a restroom large enough to accommodate a wheelchair and equipped with grab bars located near the activity area.

**(4) An area for resident activities. In a facility for which plans were approved after December 19, 1977, a restroom large enough to accommodate a wheelchair and equipped with grab bars located near the activity room shall be provided.**

**(5) For facilities and additions to facilities for which construction plans are submitted for approval after July 1, 1984, the total area for resident dining, activities, and lounge purposes shall not be less than thirty (30) square feet per bed.**

(q) **(o) Each facility shall have an adequate kitchen that complies with 410 IAC 7-15.1 as follows:**

(1) The kitchen shall be properly located for efficient food service and be large enough to accommodate the equipment and personnel needed to prepare and serve the number of meals required.

(2) Available storage space in a room adjacent to or convenient to the kitchen shall be provided for at least a three (3) day supply of staple food both for normal and emergency needs.

(3) A supervisory work area, not necessarily in the kitchen, but including space for at least one (1) desk, chair, bookshelf, and filing cabinet, shall be provided.

(4) Facilities having continuing food service deficiencies that are directly attributable to inadequacies in the size of the kitchen; food storage area; food preparation or dish washing area or to inadequacies in furnishings, equipment or arrangement will require a special plan of correction. The plan of correction shall be prepared by a person having knowledge in the design of food service operations, such as a registered dietitian; food facilities consultant; or licensed architect or registered engineer.

(5) This rule does not preclude the development of alternate food preparation and service systems. If a facility wishes to



implement an alternate system; a written proposal and plan of operation shall be submitted to the director for review and approval.

**410 IAC 7-20.**

(~~r~~) **Each (p)** The facility shall have a janitor's closet conveniently located on each resident occupied floor of the facility. The janitor's closet shall contain a sink or floor receptacle and storage for cleaning supplies. The door to the janitor's closet shall be equipped with a lock and shall be locked when hazardous materials are stored in the closet.

(~~s~~) **Each (q)** The facility shall have laundry services either in-house or **with a commercial laundry** by contract as follows:

(1) If a facility operates its own laundry, the laundry shall be (~~A~~) designed and operated to promote a flow of laundry from the soiled utility area toward the clean utility area to prevent contamination.

(~~B~~) adequate in size; well lighted; and ventilated to meet the needs of the facility;

(~~C~~) equipped with suitable capacity machines that shall be kept in good repair and maintained in a sanitary condition; and

(~~D~~) maintained in a clean and sanitary condition.

(2) If a facility does not maintain a laundry on the premises, a commercial laundry shall be utilized.

(3) Laundry areas shall have, at a minimum, the following:

(~~A~~) Separate areas for the storage of clean linen and soiled linen.

(~~B~~) Hand washing and toilet facilities maintained at locations convenient for laundry personnel.

(~~C~~) Separate linen carts appropriately labeled for soiled or clean linen and constructed of washable materials that shall be laundered or suitably cleaned as needed to maintain sanitation.

(4) **(2)** Written procedures for handling, storage, transportation, and processing of linens shall be posted in the laundry and shall be implemented.

(~~t~~) Each facility that has a beauty or barber shop shall locate it in a separate room in accordance with the facility's policy for hair care. Provisions shall be made for the disinfection of equipment used, such as brushes, combs, or hair rollers. The room shall be equipped with a shampoo sink that is installed and maintained in accordance with applicable plumbing codes.

(~~u~~) Each facility that provides living quarters for owners, managers, employees, and their families shall provide them in a manner that will not interfere with the privacy, well-being, comfort, and safety of the residents.

(~~r~~) **For facilities and additions to facilities for which construction plans are submitted for approval after July 1, 1984, if the facility provides therapy, the facility shall have a therapy area.**

(~~v~~) **(s)** For purposes of IC 16-28-5-1, a breach of:

(1) subsection (d) is a deficiency;

(2) subsection (e), (f), (g), (h), (i), (j), (k), (l), (m), or (n) is a noncompliance; and

(3) subsection (a), (b), (c), (d), (e), (f), (g), (h), (i), (j), (k), (l), (m), or (n) is a nonconformance.

**(1) subsection (a), (b), (c), (d), (e), (f), (k), (o), or (q) is a deficiency;**

**(2) subsection (g), (h), (i), (j), (l), (m), or (n) is a noncompliance; and**

**(3) subsection (p) or (r) is a nonconformance.**

*(Indiana State Department of Health; 410 IAC 16.2-5-1.6; filed Jan 10, 1997, 4:00 p.m.: 20 IR 1571, eff Apr 1, 1997; errata filed Jan 10, 1997, 4:00 p.m.: 20 IR 1593; errata filed Apr 10, 1997, 12:15 p.m.: 20 IR 2415; readopted filed Jul 11, 2001, 2:23 p.m.: 24 IR 4234)*

SECTION 9. 410 IAC 16.2-5-2 IS AMENDED TO READ AS FOLLOWS:

**410 IAC 16.2-5-2 Evaluation**

Authority: IC 16-28-1-7; IC 16-28-1-12

Affected: IC 16-28-5-1

Sec. 2. (a) An **assessment evaluation** of the individual needs of each resident shall be initiated prior to admission and shall be updated at least semiannually **and upon a known substantial change in the resident's condition, or more often at the resident's or facility's request. A licensed nurse shall evaluate the nursing needs of the resident.**

(b) The preadmission evaluation (interview) shall provide the baseline information for the initial **assessment evaluation**. Subsequent **assessments evaluations** shall compare the resident's current status to his **or her** status on admission and shall be used to assure that the care the resident requires is within the range of personal care and supervision provided by a residential care facility.

(c) The scope and content of the **assessment evaluation** shall be delineated in the facility policy manual, but at a minimum the needs assessment shall include an evaluation of the following:

(1) ~~Each The~~ resident's physical and mental ~~ability to manage his own affairs:~~ **status.**

(2) ~~Each The~~ resident's independence in the activities of daily living.

(3) ~~Each The~~ resident's weight taken on admission and semiannually thereafter.

(4) ~~Each If applicable, the~~ resident's height measured on admission: **ability to self-administer medications.**

(d) The **assessment evaluation** shall be documented in writing **and kept in the facility. and used by the facility personnel in meeting the medical and psychosocial needs of the resident.**

**(e) Following completion of an evaluation, the facility,**

## Proposed Rules

using appropriately trained staff members, shall identify and document the services to be provided by the facility, as follows:

- (1) The services offered to the individual resident shall be appropriate to the scope, frequency, need, and preference of the resident.
- (2) The services offered shall be reviewed and revised as appropriate, and discussed by the resident and facility as needs or desires change. Either the facility or the resident may request a service plan review.
- (3) The agreed upon service plan shall be signed and dated by the resident and a copy of the service plan shall be given to the resident upon request.
- (4) No identification and documentation of services provided is needed if evaluations subsequent to the initial evaluation indicate no need for a change in services.
- (5) If administration of medications and/or the provision of residential nursing services is needed, a licensed nurse shall be involved in identification and documentation of the services to be provided.

(e) (f) For purposes of IC 16-28-5-1, a breach of: any subsection (a) through (d) is a noncompliance:

- (1) subsection (a), (b), or (e) is a deficiency; and
- (2) subsection (c) or (d) is a noncompliance.

*(Indiana State Department of Health; 410 IAC 16.2-5-2; filed May 2, 1984, 2:50 p.m.: 7 IR 1497; filed Jan 10, 1997, 4:00 p.m.: 20 IR 1575, eff Apr 1, 1997; readopted filed Jul 11, 2001, 2:23 p.m.: 24 IR 4234)*

SECTION 10. 410 IAC 16.2-5-4 IS AMENDED TO READ AS FOLLOWS:

### 410 IAC 16.2-5-4 Health services

Authority: IC 16-28-1-7; IC 16-28-1-12  
Affected: IC 16-28-5-1

Sec. 4. (a) Personal care and supervision shall be provided based upon individual needs as follows:

- (1) Each resident shall be assisted in or occasionally given personal care, as needed.
- (2) Each resident shall show evidence of good personal hygiene and clean clothing.

Each resident shall have a primary care physician selected by the resident. If desired, the resident may designate a dentist.

(b) Personnel shall supervise the nutritional status of the residents. Each facility shall choose whether or not it administers medication and/or provides residential nursing care. These policies shall be delineated in the facility policy manual and clearly stated in the admission agreement.

(c) Bedside medications and treatments for self-administration shall be permitted with the approval of the resident's attending physician, unless self-administration of medications

is contraindicated by the facility's policy. Personal care, and assistance with activities of daily living, shall be provided based upon individual needs and preferences.

(d) The administration of drugs, medications and treatments, including alcoholic beverages, nutrition concentrates, and therapeutic supplements, the provision of residential nursing care shall be as ordered by the attending resident's physician and shall be supervised by a licensed nurse on the premises or on call as follows:

(1) Medication shall be administered by licensed nursing personnel or qualified medication aides. If medication aides handle or administer drugs or perform treatments requiring medications, the facility shall ensure that the person or persons have been properly qualified in medication administration by a state-approved course except as limited in subdivision (6):

(2) The resident shall be observed for effects of medications. Documentation of any undesirable effects shall be contained in the clinical record. The physician shall be notified immediately if undesirable effects occur, and such notification shall be documented in the clinical record.

(3) The individual administering the medication shall document the administration in the individual's medication and treatment records, including records of oxygen administration, that indicate the time, name of medication or treatment, dosage (if applicable), and name or initials of the person administering the drug or treatment, as follows:

(A) Notations shall describe nursing care provided and the reason for and results of all per required need (PRN) treatments and medications administered.

(B) The facility may use a separate medication or treatment sheet to record the information and the medication or treatment sheet may be kept separately from the nurses' notes until completed.

(C) Completed medication or treatment sheets shall be added to each individual resident's record.

(4) Medication shall be administered by the person who has prepared the doses, except under a single unit dose package system.

(5) (4) Preparation of doses for more than one (1) scheduled administration is not permitted.

(6) (5) Injectable medications shall be given only by licensed personnel.

(7) No medication shall be used for any resident other than the resident for whom it was prescribed.

(8) (6) PRN medications may be administered by a qualified medication aide (QMA) only upon authorization by a licensed nurse or physician. The QMA must receive appropriate authorization for each administration of a PRN medication. All contacts with a nurse or physician not on the premises for authorization to administer PRNs shall be documented in the nursing notes indicating the time and date of the contact.

(9) (7) Any error in medication administration shall be noted

in the resident's record. The physician shall be notified of any error in medication administration, when there are any actual or potential detrimental effects to the resident.

(e) If treatment(s) not involving medication are given by facility personnel, the treatment(s) shall be prescribed by the physician and shall be instituted using proper and safe techniques as follows:

(1) Treatments not involving medications may be given by nurse aides who have been instructed in the administration of the treatment by licensed nursing personnel. All PRN treatments, not involving medications, may be given only upon authorization by a licensed nurse.

(2) The resident shall be observed for effects of the treatment. Documentation of any undesirable effect shall be contained in the clinical record and the physician shall be notified. Such notification shall be documented in the clinical record.

(3) The person who has administered the treatment shall document such in accordance with subsection (d)(3).

(f) (e) The facility shall have available on the premises or on call the services of a licensed nurse at all times. The licensed nurse may, at the request of a resident, provide consultation and advice to residents; review clinical records; and assess the health condition of the residents. If medications are administered by the facility, then the facility shall provide at least ten (10) minutes of licensed nursing care per resident receiving medication during each two (2) week period.

(g) The facility shall develop, adopt, and implement a manual of written policies and procedures on cleaning, disinfecting, and sterilization. All procedures shall be carried out in accordance with the manual, which shall be available for the use of the facility personnel. The manual shall include procedures in the care of utensils, instruments, solutions, dressings, articles, and surfaces, including, but not limited to, the following:

(1) Bedside equipment such as commode pails, wash basins, emesis basins, bedpans, and urinals shall be maintained in a clean condition and disinfected as appropriate. Bedside equipment shall be washed and rinsed and then disinfected daily; if used by the same resident or after each use between residents by one (1) of the following techniques:

(A) Immersion for at least two (2) minutes in clean, hot water at a temperature of at least one hundred seventy degrees Fahrenheit (170°F).

(B) Immersion in a clean solution containing an appropriate disinfecting agent that will provide the equivalent bactericidal effect of a solution containing at least one hundred (100) parts per million of available chlorine as hypochlorite at a temperature between seventy-five degrees Fahrenheit (75°F) and one hundred ten degrees Fahrenheit (110°F) for at least one (1) minute.

(C) Mechanical utensil washing by a machine capable of rendering the bedside equipment clean and disinfecting by means of hot water or chemicals.

(D) Steam operated sterilizer.

(2) Bathing tubs shall be disinfected after each use.

(3) Bedside equipment and eating or drinking utensils shall not be commingled during the disinfection process.

(4) Individualized resident care supply items designed and identified by the manufacturer to be disposable shall not be reused and shall be destroyed.

(h) (f) For purposes of IC 16-28-5-1, a breach of:

(1) subsection (d) or (e) is a deficiency; and

(2) subsection (a); (b); (c); (f); or (g) is a noncompliance:

(1) subsection (d)(1), (d)(2), or (d)(5) is an offense;

(2) subsection (a), (c), (d)(3), (d)(6), (d)(7), or (e) is a deficiency;

(3) subsection (d)(4) is a noncompliance; and

(4) subsection (b) is a nonconformance.

*(Indiana State Department of Health; 410 IAC 16.2-5-4; filed May 2, 1984, 2:50 p.m.; 7 IR 1497; filed Jan 10, 1997, 4:00 p.m.; 20 IR 1576, eff Apr 1, 1997; errata filed Apr 10, 1997, 12:15 p.m.; 20 IR 2415; readopted filed Jul 11, 2001, 2:23 p.m.; 24 IR 4234)*

SECTION 11. 410 IAC 16.2-5-5.1 IS ADDED TO READ AS FOLLOWS:

**410 IAC 16.2-5-5.1 Food and nutritional services**

Authority: IC 16-28-1-7; IC 16-28-1-12

Affected: IC 16-28-5-1

**Sec. 5.1. (a) The facility shall provide, arrange, or make available three (3) well-planned meals a day, seven (7) days a week that provide a balanced distribution of the daily nutritional requirements.**

**(b) The menu or substitutions, or both, for all meals shall be approved by a registered dietician.**

**(c) The facility must meet:**

**(1) daily dietary requirements and requests, with consideration of food allergies;**

**(2) reasonable religious, ethnic, and personal preferences; and**

**(3) the temporary need for meals delivered to the resident's room.**

**(d) All modified diets shall be prescribed by the attending physician.**

**(e) All food shall be served at a safe and appropriate temperature.**

**(f) All food preparation and serving areas (excluding areas in residents' units) are maintained in accordance with state and local sanitation and safe food handling standards, including 410 IAC 7-20.**

**(g) There shall be an organized food service department directed by a supervisor competent in food service manage-**

## Proposed Rules

ment and knowledgeable in sanitation standards, food handling, food preparation, and meal service.

(1) The supervisor must be one (1) of the following:

(A) A dietitian.

(B) A graduate or student enrolled in and within one (1) year from completing a division approved, minimum ninety (90) hour classroom instruction course that provides classroom instruction in food service supervision who has a minimum of one (1) year of experience in some aspect of institutional food service management.

(C) A graduate of a dietetic technician program approved by the American Dietetic Association.

(D) A graduate of an accredited college or university or within one (1) year of graduating from an accredited college or university with a degree in foods and nutrition or food administration with a minimum of one (1) year of experience in some aspect of food service management.

(E) An individual with training and experience in food service supervision and management.

(2) If the supervisor is not a dietitian, a dietitian shall provide consultant services on the premises at peak periods of operation on a regularly scheduled basis.

(3) Food service staff shall be on duty to ensure proper food preparation, serving, and sanitation.

(h) Diet orders shall be reviewed and revised by the physician as the resident's condition requires.

(i) For purposes of IC 16-28-5-1, a breach of:

(1) subsection (a), (c), (d), (e), (f), or (h) is a deficiency; and

(2) subsection (b) or (g) is a noncompliance.

(Indiana State Department of Health; 410 IAC 16.2-5-5.1)

SECTION 12. 410 IAC 16.2-5-6 IS AMENDED TO READ AS FOLLOWS:

### 410 IAC 16.2-5-6 Pharmaceutical services

Authority: IC 16-28-1-7; IC 16-28-1-12

Affected: IC 16-28-5-1; IC 25-26-13

Sec. 6. (a) If the Residents retain and self-administer medications, the facility shall make arrangements to ensure that pharmaceutical services are available to provide residents with prescribed who self-medicate may keep and use prescription and nonprescription medications in accordance with applicable laws of Indiana if requested by the their unit as long as they keep them secured from other residents.

(b) The facility shall maintain clear written policies and procedures on medication assistance. The facility shall provide for ongoing training to ensure competence of medication staff.

(c) If the facility controls, handles, and administers medications for a resident, the facility shall do the following for that resident:

(1) Make arrangements to ensure that pharmaceutical services are available to provide residents with prescribed medications in accordance with applicable laws of Indiana.

(2) A consultant pharmacist shall be employed, or under contract, and shall:

(A) be responsible for the duties as specified in ~~856 IAC 1-7-7~~ as follows: **856 IAC 1-7**;

(~~A~~) (B) review the drug handling and storage practices in the facility;

(~~B~~) (C) provide consultation on methods and procedures of ordering, storing, administering, and disposing of drugs as well as medication record keeping;

(~~C~~) (D) report, in writing, to the administrator and director of nursing or his or her designee any irregularities in dispensing or administration of drugs; and

(E) review the drug regimen of each resident receiving these services at least once every sixty (60) days.

(~~3~~) Pharmacy consultation shall be provided to licensed personnel.

(~~4~~) The consultant pharmacist shall provide written reports to the administrator of the frequency, nature, and duration of the visits to the facility.

(~~5~~) (3) The medication review, and recommendations, shall be documented as well as the and notification of the physician, if necessary, shall be documented in accordance with the facility's policy.

(~~6~~) A facility shall not purchase or store anywhere on the premises any drug for a resident except those prescribed or ordered for the individual resident by the physician and those drugs authorized for the emergency kit.

(4) Over-the-counter medications, prescription drugs, and biologicals used in the facility must be labeled in accordance with currently accepted professional principles, and include the appropriate accessory and cautionary instructions and the expiration date.

(~~c~~) If a facility operates its own duly licensed pharmacy, it shall comply with IC 25-26-13.

(~~d~~) The facility shall only utilize a pharmacy that:

(1) complies with the facility policy regarding receiving, packaging, and labeling of pharmaceutical products unless contrary to state and federal laws and rules on pharmacy practices;

(2) provides prescribed drugs, including the availability of a twenty-four (24) hour prescription service on a prompt and timely basis; and

(3) refills prescription drugs, when needed, in order to prevent interruption of drug regimens.

(~~e~~) All drugs shall be labeled in compliance with state and federal laws governing prescription dispensing. If the facility receives incorrectly labeled medications, the pharmacy shall be notified immediately. Labeling shall be done as follows:

(~~1~~) (5) Labeling of prescription drugs shall include the following:

- (A) ~~The~~ Resident's full name.
- (B) ~~The~~ Physician's name.
- (C) ~~The~~ Prescription number.
- (D) ~~The~~ Name and strength of the drug.
- (E) Directions for use.
- (F) Date of issue **and**
- (G) ~~An~~ expiration date (when applicable).
- (H) ~~The~~ (G) Name and address of the pharmacy that filled the prescription.

If a facility is supplied medication **is packaged** in a unit dose, ~~packaging~~, reasonable variations ~~which that~~ comply with the acceptable pharmaceutical procedures are permitted.

- (2) Nursing supplies, such as hydrogen peroxide, sterile water, rubbing alcohol, nonmedicated skin preparations, and emollients, need not comply with subdivision (1), although such supplies must be in the original manufacturer's container with the manufacturer's label intact.
- (3) Therapeutic concentrates, nutritional supplements, and alcoholic beverages shall be labeled in conformance with state and federal food and drug laws. Such items shall be in containers with the original manufacturer's label still intact and legible. Containers of therapeutic concentrates, that is, vitamins or minerals, shall be identified with the resident's name and room number.
- (4) No person other than the dispenser of the drug shall alter any prescription label.
- (5) The labels on all medications shall be clean and legible. If, in the opinion of the consultant pharmacist or licensed nurse, the labels on the medication are illegible, the medication shall either be relabeled by the issuing pharmacy or destroyed. Containers that are cracked, soiled, or without secure closure shall not be used.
- (6) Over-the-counter medications must be identified with the following:
  - (A) Resident name.
  - (B) Physician name.
  - (C) Expiration date.
  - (D) Name of drug.
  - (E) Strength.

**(d) If a facility operates its own duly licensed pharmacy, it shall comply with IC 25-26-13.**

~~(f)~~ **(e)** Medicine or treatment cabinets or rooms shall be **appropriately** locked at all times except when authorized personnel are present. These cabinets shall also be used as follows:

- (1) The key for the lock of the room or cabinet shall be carried or be accessible to only those persons authorized to handle and administer drugs.
- (2) Drugs shall be stored in a clean and orderly manner in cabinets, drawers, or carts of sufficient size to prevent crowding.
- (3) All Schedule II drugs ~~individually prescribed~~ **administered by the facility** shall be kept in individual containers

under double lock and stored in a substantially constructed box, cabinet, or mobile drug storage unit.

- (4) ~~Bedside medications for self-administration shall be allowed only upon order of the resident's attending physician.~~
- (5) ~~Only authorized personnel shall handle or administer drugs or other therapy as specified in section 4(d) of this rule.~~
- (6) ~~Emergency medication shall be stored in a suitable box or cubicle equipped with a seat.~~

~~(g) Discontinued, outdated, or deteriorated medication shall not be maintained or used in the facility. Medications shall be disposed of in compliance with federal, state, and local laws as follows:~~

- (1) ~~All unused portions of any properly labeled medications, including controlled substances, shall be released to the discharged resident upon written order of the physician.~~
- (2) ~~Unopened and unexposed medication may be returned to the issuing pharmacy for credit to the appropriate party.~~
- (3) ~~Unused portions of medications not released with the resident or returned for credit shall be destroyed on the premises within seven (7) days by the consultant pharmacist or licensed nurse with a witness.~~
- (4)

**(f) Residents may use the pharmacy of their choice for medications administered by the facility, as long as the pharmacy:**

- (1) **complies with the facility policy receiving, packaging, and labeling of pharmaceutical products unless contrary to state and federal laws;**
- (2) **provides prescribed service on a prompt and timely basis; and**
- (3) **refills prescription drugs when needed, in order to prevent interruption of drug regimens.**

**(g) Medications administered by the facility shall be disposed in compliance with appropriate federal, state, and local laws, and disposition of any released, returned, or destroyed medication shall be written documented in the resident's clinical record and shall include the following information:**

- ~~(A)~~ **(1)** The name of the resident.
- ~~(B)~~ **(2)** The name and strength of the drug.
- ~~(C)~~ **(3)** The prescription number.
- ~~(D)~~ **(4)** The reason for disposal.
- ~~(E)~~ **(5)** The amount disposed of.
- ~~(F)~~ **(6)** The method of disposition.
- ~~(G)~~ **(7)** The date of the disposal.
- ~~(H)~~ **(8)** The ~~signatures~~ **signature** of the persons ~~person~~ conducting the disposal of the drug.
- (9) The signature of a witness, if any, to the disposal of the drug.**

(h) For purposes of IC 16-28-5-1, a breach of:  
 (1) subsection (a); (b)(1); or (f) is a deficiency; and

## Proposed Rules

(2) subsection (b)(2), (b)(3), (b)(4), (b)(5), (b)(6), (c), (d), (e), or (g) is a noncompliance.

(1) subsection (c)(2), (c)(4), (c)(5), (c)(6), (d), or (e) is a deficiency; and

(2) subsection (a), (b), (c)(1), (c)(3), (f), or (g) is a noncompliance.

*(Indiana State Department of Health; 410 IAC 16.2-5-6; filed May 2, 1984, 2:50 p.m.: 7 IR 1498; filed Jan 10, 1997, 4:00 p.m.: 20 IR 1579, eff. Apr 1, 1997; readopted filed Jul 11, 2001, 2:23 p.m.: 24 IR 4234)*

SECTION 13. 410 IAC 16.2-5-7.1 IS ADDED TO READ AS FOLLOWS:

### 410 IAC 16.2-5-7.1 Activities programs

Authority: IC 16-28-1-7; IC 16-28-1-12

Affected: IC 16-28-5-1

Sec. 7.1. (a) The facility shall provide activities programs appropriate to the abilities and interests of the residents being served.

(b) The facility shall provide and/or coordinate scheduled transportation to community-based activities.

(c) An activities director shall be designated and must be one (1) of the following:

(1) A recreation therapist.

(2) An occupational therapist or a certified occupational therapy assistant.

(3) An individual who has satisfactorily completed or will complete within one (1) year an activities director course approved by the division.

(d) After July 1, 1984, any person who has not completed an activities director course approved by the division shall receive consultation until the person has completed such a course. Consultation shall be provided by:

(1) a recreation therapist;

(2) an occupational therapist or occupational therapist assistant; or

(3) a person who has completed a division approved course and has two (2) years of experience.

(e) For purposes of IC 16-28-5-1, a breach of:

(1) subsection (a) is a deficiency;

(2) subsection (c) or (d) is a noncompliance; and

(3) subsection (b) is a nonconformance.

*(Indiana State Department of Health; 410 IAC 16.2-5-7.1)*

SECTION 14. 410 IAC 16.2-5-8.1 IS ADDED TO READ AS FOLLOWS:

### 410 IAC 16.2-5-8.1 Clinical records

Authority: IC 16-28-1-7; IC 16-28-1-12

Affected: IC 16-28-5-1

Sec. 8.1. (a) The facility must maintain clinical records on each resident. These records must be maintained under the supervision of an employee of the facility designated with that responsibility. The records must be as follows:

(1) Complete.

(2) Accurately documented.

(3) Readily accessible.

(4) Systematically organized.

(b) Clinical records must be retained after discharge:

(1) for a minimum period of one (1) year in the facility and five (5) years total; or

(2) for a minor, until twenty-one (21) years of age.

(c) The facility must safeguard clinical record information against loss, destruction, or unauthorized use.

(d) The facility must keep confidential all information contained in the resident's records, regardless of the form or storage method of the records, and release such records only as permitted by law.

(e) The clinical record must contain the following:

(1) Sufficient information to identify the resident.

(2) A record of the resident's evaluations.

(3) Services provided.

(4) Progress notes.

(f) The facility shall have a policy that ensures the staff has sufficient information to meet the residents' needs.

(g) A transfer form shall include the following:

(1) Identification data.

(2) Name of the transferring institution.

(3) Name of the receiving institution and date of transfer.

(4) Resident's personal property when transferred to an acute care facility.

(5) Nurses' notes relating to the resident's:

(A) functional abilities and physical limitations;

(B) nursing care;

(C) medications;

(D) treatment; and

(E) current diet and condition on transfer.

(6) Diagnosis.

(7) Date of chest x-ray and skin test for tuberculosis.

(h) Current clinical records shall be completed promptly and those of discharged residents shall be completed within seventy (70) days of the discharge date.

(i) A current emergency information file shall be immediately accessible for each resident, in case of emergency, that contains the following:

(1) The resident's name, sex, room, or apartment number, phone number, age or date of birth.

(2) The resident's hospital preference.

- (3) The name and phone number of any legally authorized representative.
- (4) The name and phone number of the resident's physician of record.
- (5) The name and telephone number of the family members or other persons to be contacted in the event of an emergency or death.
- (6) Information on any known allergies.
- (7) A photograph (for identification of the resident).
- (8) Copy of advance directives, if available.

(j) If a death occurs, information concerning the resident's death shall include the following:

- (1) Notification of the physician, family, responsible person, and legal representative.
- (2) The disposition of the body, personal possessions, and medications.
- (3) A complete and accurate notation of the resident's condition and most recent vital signs and symptoms preceding death.

(k) The facility shall store inactive clinical records in accordance with applicable state and federal laws in a safe and accessible manner. The storage facilities shall provide protection from vermin and unauthorized use.

- (l) For purposes of IC 16-28-5-1, a breach of:
  - (1) subsection (a), (c), (d), (e), (f), (g), (i), or (j) is a non-compliance; and
  - (2) subsection (b), (h), or (k) is a nonconformance.

(Indiana State Department of Health; 410 IAC 16.2-5-8.1)

SECTION 15. 410 IAC 16.2-5-11.1 IS ADDED TO READ AS FOLLOWS:

**410 IAC 16.2-5-11.1 Mental health screening for individuals who are recipients of Medicaid or federal Supplemental Security Income**

Authority: IC 16-28-1-7; IC 16-28-1-12  
Affected: IC 12-10-6; IC 16-28-5-1

Sec. 11.1. (a) As used in this section, "mental health service provider", means the community mental health center local to the residential care facility.

(b) If the individual is a recipient of Medicaid or federal Supplemental Security Income (SSI) the individual needs evaluation provided in section 2(a) of this rule shall include, but not be limited to, the following:

- (1) Screening of the individual for major mental illness, such as a diagnosed major mental illness, is limited to the following disorders:
  - (A) Schizophrenia.
  - (B) Schizoaffective disorder.
  - (C) Mood (bipolar and major depressive type) disorder.

- (D) Paranoid or delusional disorder.
- (E) Panic or other severe anxiety disorder.
- (F) Somatoform or paranoid disorder.
- (G) Personality disorder.
- (H) Atypical psychosis or other psychotic disorder (not otherwise specified).
- (2) Obtaining a history of treatment received by the individual for a major mental illness within the last two (2) years.
- (3) Obtaining a history of individual behavior within the last two (2) years that would be considered dangerous to facility residents, the staff, or the individual.

(c) If a person is a recipient of Medicaid or federal SSI and has a major mental illness as defined by the individual needs assessment, the person will be referred to the mental health service provider for a consultation on needed treatment services. All residents who participate in Medicaid or SSI admitted after April 1, 1997, shall have a completed individual needs assessment in their clinical record. All persons admitted after April 1, 1997, shall have the assessment completed prior to the admission, and, if a mental health center consultation is needed, the consultation shall be completed prior to the admission and a copy maintained in the clinical record.

(d) When a state hospital refers a person with a major mental illness, the residential care facility shall request that a copy of the psychosocial and treatment recommendations collaboratively developed between the state hospital and the mental health center be forwarded to the residential care facility so that the residential care facility can determine the degree to which it can provide or arrange for the provision of such service.

- (e) The residential care facility shall not admit residents with a major mental illness if:
  - (1) the mental health service provider determines that the resident's needs cannot be met; and
  - (2) the residential care facility does not have a means to access needed services to carry out the comprehensive care plan.

(f) Each resident with a major mental illness must have a comprehensive care plan that is developed within thirty (30) days after admission to the residential care facility.

- (g) The residential care facility, in cooperation with the mental health service providers, shall develop the comprehensive care plan for the resident that includes the following:
  - (1) Psychosocial rehabilitation services that are to be provided within the community.
  - (2) A comprehensive range of activities to meet multiple levels of need, including the following:
    - (A) Recreational and socialization activities.
    - (B) Social skills.

## Proposed Rules

(C) Training, occupational, and work programs.

(D) Opportunities for progression into less restrictive and more independent living arrangements.

(h) The residential care facility shall provide or arrange for services to carry out the resident's comprehensive care plan.

(i) The residential care facility shall seek appropriate alternate placement in accordance with 410 IAC 16.2-2-3 if the resident's needs or comprehensive care plan, or both, cannot be met by the residential care facility.

(j) The facility must comply with IC 12-10-6 for those residents eligible for residential care assistance.

(k) For purposes of IC 16-28-5-1, a breach of:

(1) subsection (e) is an offense;

(2) subsection (b), (c), (g), (h), or (i) is a deficiency; and

(3) subsection (d), (f), or (j) is a noncompliance.

(Indiana State Department of Health; 410 IAC 16.2-5-11.1)

SECTION 16. 410 IAC 16.2-5-12 IS ADDED TO READ AS FOLLOWS:

### 410 IAC 16.2-5-12 Infection control

Authority: IC 16-28-1-7; IC 16-28-1-12

Affected: IC 4-21.5; IC 16-28-5-1

Sec. 12. (a) The facility must establish and maintain an infection control practice designed to provide a safe, sanitary, and comfortable environment and to help prevent the development and transmission of diseases and infection.

(b) The facility must establish an infection control program that includes the following:

(1) A system that enables the facility to analyze patterns of known infectious symptoms.

(2) Provides orientation and in-service education on infection prevention and control, including universal precautions.

(3) Offering health information to residents, including, but not limited to, infection transmission and immunizations.

(4) Reporting communicable disease to public health authorities.

(c) Each resident shall have a diagnostic chest x-ray completed no more than six (6) months prior to admission.

(d) Prior to admission, each resident shall be required to have a health assessment, including history of significant past or present infectious diseases and a statement that the resident shows no evidence of tuberculosis in an infectious stage as verified upon admission and yearly thereafter.

(e) In addition, a tuberculin skin test shall be completed

within three (3) months prior to admission or upon admission and read at forty-eight (48) to seventy-two (72) hours. The result shall be recorded in millimeters of induration with the date given, date read, and by whom administered and read.

(f) For residents who have not had a documented negative tuberculin skin test result during the preceding twelve (12) months, the baseline tuberculin skin testing should employ the two-step method. If the first step is negative, a second test should be performed within one (1) to three (3) weeks after the first test. The frequency of repeat testing will depend on the risk of infection with tuberculosis.

(g) All residents who have a positive reaction to the tuberculin skin test shall be required to have a chest x-ray and other physical and laboratory examinations in order to complete a diagnosis.

(h) All skin testing for tuberculosis shall be done using the Mantoux method (5TU, PPD) administered by persons having documentation of training from a department-approved course of instruction in intradermal tuberculin skin testing, reading, and recording.

(i) Persons with a documented history of a positive tuberculin skin test, adequate treatment for disease, or preventive therapy for infection, shall be exempt from further skin testing. In lieu of a tuberculin skin test, these persons should have an annual risk assessment for the development of symptoms suggestive of tuberculosis, including, but not limited to, cough, fever, night sweats, and weight loss. If symptoms are present, the individual shall be evaluated immediately with a chest x-ray.

(j) When the infection control program determines that a resident needs isolation to prevent the spread of infection, the facility must isolate the resident only to the degree needed to isolate the infecting organism.

(k) The facility must require staff to wash their hands after each direct resident contact for which hand washing is indicated by accepted professional practice.

(l) For purposes of IC 16-28-5-1, a breach of:

(1) subsection (a) is an offense;

(2) subsection (j) or (k) is a deficiency; and

(3) subsection (b), (c), (d), (e), (f), (g), (h), or (i) is a noncompliance.

(Indiana State Department of Health; 410 IAC 16.2-5-12)

SECTION 17. THE FOLLOWING ARE REPEALED: 410 IAC 16.2-1-0.5; 410 IAC 16.2-1-1; 410 IAC 16.2-1-2; 410 IAC 16.2-1-2.1; 410 IAC 16.2-1-2.2; 410 IAC 16.2-1-3; 410 IAC 16.2-1-3.5; 410 IAC 16.2-1-5; 410 IAC 16.2-1-6; 410 IAC 16.2-1-6.5; 410 IAC 16.2-1-7; 410 IAC 16.2-1-8; 410 IAC



16.2-1-9; 410 IAC 16.2-1-10.1; 410 IAC 16.2-1-10.2; 410 IAC 16.2-1-11; 410 IAC 16.2-1-12.5; 410 IAC 16.2-1-14; 410 IAC 16.2-1-14.1; 410 IAC 16.2-1-14.2; 410 IAC 16.2-1-15; 410 IAC 16.2-1-15.1; 410 IAC 16.2-1-15.2; 410 IAC 16.2-1-15.3; 410 IAC 16.2-1-16; 410 IAC 16.2-1-17; 410 IAC 16.2-1-18; 410 IAC 16.2-1-18.1; 410 IAC 16.2-1-18.2; 410 IAC 16.2-1-19; 410 IAC 16.2-1-19.1; 410 IAC 16.2-1-20; 410 IAC 16.2-1-21; 410 IAC 16.2-1-22; 410 IAC 16.2-1-22.1; 410 IAC 16.2-1-22.2; 410 IAC 16.2-1-23; 410 IAC 16.2-1-24; 410 IAC 16.2-1-25; 410 IAC 16.2-1-26; 410 IAC 16.2-1-26.1; 410 IAC 16.2-1-27; 410 IAC 16.2-1-27.1; 410 IAC 16.2-1-28; 410 IAC 16.2-1-29; 410 IAC 16.2-1-29.1; 410 IAC 16.2-1-30; 410 IAC 16.2-1-31; 410 IAC 16.2-1-31.1; 410 IAC 16.2-1-32; 410 IAC 16.2-1-32.1; 410 IAC 16.2-1-32.2; 410 IAC 16.2-1-33; 410 IAC 16.2-1-34; 410 IAC 16.2-1-35; 410 IAC 16.2-1-36; 410 IAC 16.2-1-37; 410 IAC 16.2-1-38; 410 IAC 16.2-1-39; 410 IAC 16.2-1-39.1; 410 IAC 16.2-1-41.1; 410 IAC 16.2-1-42; 410 IAC 16.2-1-44; 410 IAC 16.2-1-45; 410 IAC 16.2-1-46; 410 IAC 16.2-1-47; 410 IAC 16.2-1-48; 410 IAC 16.2-5-1.7; 410 IAC 16.2-5-3; 410 IAC 16.2-5-5; 410 IAC 16.2-5-7; 410 IAC 16.2-5-8; 410 IAC 16.2-5-9; 410 IAC 16.2-5-10; 410 IAC 16.2-5-11.

**Notice of Public Hearing**

*Under IC 4-22-2-24, notice is hereby given that on July 22, 2002 at 2:00 p.m., at the Indiana State Department of Health, 2 North Meridian Street, Rice Auditorium, Indianapolis, Indiana the Indiana State Department of Health will hold a public hearing on proposed new rules to update and add definitions. Amends 410 IAC 16.2-5 to update health and sanitation standards, qualifications of applicants for licensure, requirements for operation, maintenance, and management, and other requirements for the operation of residential care facilities. Copies of these rules are now on file at the Indiana State Department of Health, Health Care Regulatory Services Commission, 2 North Meridian Street, and Legislative Services Agency, One North Capitol, Suite 325, Indianapolis, Indiana and are open for public inspection.*

Gregory A. Wilson, M.D.  
State Health Commissioner  
Indiana State Department of Health

---

---

**TITLE 440 DIVISION OF MENTAL HEALTH  
AND ADDICTION**

**Proposed Rule**  
LSA Document #02-42

**DIGEST**

Adds 440 IAC 1.5 concerning the licensure of private mental health institutions. Repeals 440 IAC 1-1.5. Effective 30 days after filing with the secretary of state.

**440 IAC 1-1.5**  
**440 IAC 1.5**

SECTION 1. 440 IAC 1.5 IS ADDED TO READ AS FOLLOWS:

**ARTICLE 1.5. LICENSURE OF PRIVATE MENTAL  
HEALTH INSTITUTIONS**

**Rule 1. Definitions**

**440 IAC 1.5-1-1 Applicability**

Authority: IC 12-8-8-4; IC 12-21-2-3; IC 12-25-1-2  
Affected: IC 12-25

**Sec. 1. The definitions in this rule apply throughout this article.** *(Division of Mental Health and Addiction; 440 IAC 1.5-1-1)*

**440 IAC 1.5-1-2 "Accreditation" defined**

Authority: IC 12-8-8-4; IC 12-21-2-3; IC 12-25-1-2  
Affected: IC 12-25

**Sec. 2. "Accreditation" means an accrediting agency has determined that a private mental health institution has met specific requirements of the accrediting agency.** *(Division of Mental Health and Addiction; 440 IAC 1.5-1-2)*

**440 IAC 1.5-1-3 "Accrediting agency" defined**

Authority: IC 12-8-8-4; IC 12-21-2-3; IC 12-25-1-2  
Affected: IC 12-25

**Sec. 3. "Accrediting agency" means an organization, included on a list of accrediting organizations approved by the division, which has developed clinical, financial, and organizational standards for the operation of a provider of mental health services and which evaluates a private mental health institution's compliance with its established standards on a regularly scheduled basis.** *(Division of Mental Health and Addiction; 440 IAC 1.5-1-3)*

**440 IAC 1.5-1-4 "Consumer" defined**

Authority: IC 12-8-8-4; IC 12-21-2-3; IC 12-25-1-2  
Affected: IC 12-25

**Sec. 4. "Consumer" means an individual who is receiving assessment or mental health services from the private mental health institution.** *(Division of Mental Health and Addiction; 440 IAC 1.5-1-4)*

**440 IAC 1.5-1-5 "Division" defined**

Authority: IC 12-8-8-4; IC 12-21-2-3; IC 12-25-1-2  
Affected: IC 12-25

**Sec. 5. "Division" means the division of mental health and addiction.** *(Division of Mental Health and Addiction; 440 IAC 1.5-1-5)*

**440 IAC 1.5-1-6 "Licensed mental health professional" defined**

Authority: IC 12-8-8-4; IC 12-21-2-3; IC 12-25-1-2  
Affected: IC 12-25

## Proposed Rules

Sec. 6. "Licensed mental health professional" means a mental health professional whose scope of practice under Indiana licensure encompasses the expertise involved in writing orders for treatment and who is appropriately credentialed under the private mental health institution's bylaws and policies to write such orders. (*Division of Mental Health and Addiction; 440 IAC 1.5-1-6*)

### 440 IAC 1.5-1-7 "Mental health services" defined

Authority: IC 12-8-8-4; IC 12-21-2-3; IC 12-25-1-2

Affected: IC 12-25

Sec. 7. "Mental health services" means psychological services, counseling services, case management services, residential services, and other social services for the treatment and care of individuals with psychiatric disorders or chronic addictive disorders, or both. (*Division of Mental Health and Addiction; 440 IAC 1.5-1-7*)

### 440 IAC 1.5-1-8 "Private mental health institution" defined

Authority: IC 12-8-8-4; IC 12-21-2-3; IC 12-25-1-2

Affected: IC 12-25; IC 16

Sec. 8. "Private mental health institution" means an inpatient hospital setting, including inpatient and outpatient services provided in that setting, for the treatment and care of individuals with psychiatric disorders or chronic addictive disorders, or both, that is physically, organizationally, and programmatically independent of any hospital or health facility licensed by the Indiana state department of health under IC 16. (*Division of Mental Health and Addiction; 440 IAC 1.5-1-8*)

### 440 IAC 1.5-1-9 "PRN" defined

Authority: IC 12-8-8-4; IC 12-21-2-3; IC 12-25-1-2

Affected: IC 12-25

Sec. 9. "PRN" means as needed. (*Division of Mental Health and Addiction; 440 IAC 1.5-1-9*)

## Rule 2. General Provisions

### 440 IAC 1.5-2-1 Applicability

Authority: IC 12-8-8-4; IC 12-21-2-3; IC 12-25-1-2

Affected: IC 12-25; IC 16

Sec. 1. This article applies to any inpatient, hospital setting, including inpatient and outpatient services provided in that setting, for the treatment and care of individuals with psychiatric disorders or chronic addictive disorders, or both, that is physically, organizationally, and programmatically independent of any hospital or health facility licensed by the Indiana state department of health under IC 16. (*Division of Mental Health and Addiction; 440 IAC 1.5-2-1*)

### 440 IAC 1.5-2-2 Licensure by the division

Authority: IC 12-8-8-4; IC 12-21-2-3; IC 12-25-1-2

Affected: IC 12-25

Sec. 2. (a) Before an entity may operate as a private mental health institution, the entity must be licensed by the division under this article.

(b) A private mental health institution shall be accredited by an accrediting agency approved by the division.

(c) The following components are required to be present for licensure as a private mental health institution:

- (1) Governing board.
- (2) Medical or professional staff organization.
- (3) Quality assessment and improvement program.
- (4) Dietetic service.
- (5) Infection control program.
- (6) Medical record services.
- (7) Nursing service.
- (8) Physical plant, maintenance, and environmental services.
- (9) Intake and treatment services.
- (10) Discharge planning services.
- (11) Pharmacy services.
- (12) Plan for special procedures.

(d) The private mental health institution shall have a written plan that clearly defines their course of action and arrangements for emergency services.

(e) The facility shall make a verbal report to the division within twenty-four (24) hours of occurrence of any of the following:

- (1) Death or kidnaping of consumer occurring after admission.
- (2) A disruption, exceeding four (4) hours, in the continued safe operation of the facility or in the provision of consumer care, caused by internal or external disasters, strikes by health care workers, or unscheduled revocation of vital services.
- (3) Any fire or explosion.

(f) In addition, a written report on occurrences listed in subsection (e) shall be submitted to the division within ten (10) working days.

(g) The facility shall make a written report within ten (10) working days of the occurrence of any of the following:

- (1) Serious consumer injuries with the potential of a loss of function or marked deterioration of a consumer's condition occurring under unanticipated or unexpected circumstances.
- (2) Chemical poisoning occurring within the facility resulting in a negative consumer outcome.
- (3) Unexplained loss of or theft of a controlled substance.
- (4) Missing consumer whose whereabouts are unknown for over twenty-four (24) hours.

(h) All written reports shall include the following:

(1) An explanation of the circumstances surrounding the incident.

(2) Summaries of all findings, conclusions, and recommendations associated with the review of the incident.

(3) A summary of actions taken to resolve identified problems, to prevent recurrence of the incident, and to improve overall consumer care.

(i) In the event of flood, fire, or other disaster, when significant damage has occurred to the facility, the governing board, or the governing board's designee, or the director of the division shall suspend the use of all or that part of the facility as may be necessary to ensure the safety and well being of consumers. The director of the division shall issue a permit to reoccupy the facility after it is inspected and approved as safe by the Indiana state department of health or the department of fire prevention and building safety commission, or both.

(j) A private mental health institution that has applied for licensure or has been licensed must supply any information requested by the division as fully as it is capable. Failure to comply with a request from the division may result in revocation or denial of a private mental health institution's licensure.

(k) As the licensing body, the division may conduct inspections and investigate complaints and incidents in any private mental health institution.

(l) A private mental health institution's license shall be posted in a conspicuous place in the facility open to consumers and the public. (*Division of Mental Health and Addiction; 440 IAC 1.5-2-2*)

#### **440 IAC 1.5-2-3 Application for licensure**

Authority: IC 12-8-8-4; IC 12-21-2-3; IC 12-25-1-2

Affected: IC 12-25-1-6

**Sec. 3. (a)** An entity seeking licensure as a private mental health institution shall file an application with the division.

(b) The application shall contain the following:

(1) A description of the organizational structure and mission of the applicant.

(2) The location of all operational sites of the applicant.

(3) The consumer population to be served, and the program focus.

(4) List of governing board members and executive staff.

(5) A copy of the applicant's procedures to ensure protection of consumer rights and confidentiality.

(6) Evidence of an on-site review and inspection by the Indiana state department of health, and the correction of any deficiencies.

(7) Evidence of an on-site review and inspection by the department of fire prevention and building safety commission, and the correction of any deficiencies.

(8) Other materials as requested by the division to assist in the evaluation of the application.

(c) An applicant that is accredited must forward to the division proof of accreditation in all services provided by the applicant, site survey recommendations from the accrediting agency, and the applicant's responses to the site survey recommendations.

(d) The division may require the applicant to correct any deficiencies described in the site survey.

(e) If the entity is not yet accredited in all services provided by the applicant, a temporary license may be issued for six (6) months, if the entity provides proof of application to an accrediting body approved by the division.

(f) If the nonaccredited entity continues to meet the other requirements for licensure, temporary licensure may be extended for no more than six (6) additional months.

(g) Before the extended temporary license expires, the applicant must forward to the division the following:

(1) Proof of accreditation.

(2) Site survey recommendations from the accrediting agency.

(3) The applicant's responses to the site survey recommendations.

(4) The division may require the applicant to correct any deficiencies described in the site survey.

(5) Any other materials requested by the division as a part of the application process.

(h) If the applicant fails to achieve accreditation within twelve (12) months, the applicant may not reapply for licensure until twelve (12) months after the extended temporary license ends.

(i) The division may issue a license as a private mental health institution to the applicant after the division has determined that the applicant meets all criteria for a private mental health institution set forth in this rule and in federal and state law.

(j) The regular licensure shall expire one (1) year after the date of issuance.

(k) Relicensure of a facility is required when any of the following occur:

(1) Change in ownership.

(2) Change in the location of the physical plant.

(3) Change in the primary program focus.

(4) When the existing license expires.

(l) The applicant has the right to a hearing conducted by the director of the division or the director's designee, pursuant to IC 12-25-1-6.

## Proposed Rules

(m) If an applicant is denied licensure, a new application for licensure may not be submitted until twelve (12) months have passed. (*Division of Mental Health and Addiction; 440 IAC 1.5-2-3*)

### 440 IAC 1.5-2-4 Maintenance of licensure

Authority: IC 12-8-8-4; IC 12-21-2-3; IC 12-25-1-2  
Affected: IC 12-25; IC 12-27

Sec. 4. Maintenance of licensure is dependent upon the following:

(1) The private mental health institution shall maintain accreditation from an accrediting agency approved by the division. The division shall annually provide all private mental health institutions with a list of accrediting agencies approved by the division.

(2) The private mental health institution shall maintain compliance with required health, fire, and safety codes as prescribed by federal, state, and local law.

(3) Each private mental health institution shall have written policies and enforce these policies to support and protect the fundamental human, civil, constitutional, and statutory rights of each consumer.

(4) Each private mental health institution shall do the following:

(A) Give a written statement of rights under IC 12-27 to each consumer. The statement shall include the toll free consumer service line number and the telephone number for Indiana protection and advocacy services.

(B) Post the written statement of rights in the reception area of the facility.

(C) Document that staff provides both a written and an oral explanation of these rights to each consumer.

(D) Each private mental health institution shall respond to complaints from the consumer service line in a timely manner.

(*Division of Mental Health and Addiction; 440 IAC 1.5-2-4*)

### 440 IAC 1.5-2-5 Notification of changes

Authority: IC 12-8-8-4; IC 12-21-2-3; IC 12-25-1-2  
Affected: IC 12-25; IC 12-27

Sec. 5. (a) A private mental health institution must notify the division, in writing, thirty (30) days prior to any of the following:

(1) Change in the location of the private mental health institution's operational site.

(2) Change in the primary program focus.

(3) Date of the scheduled accreditation survey and the name of the accrediting agency to provide accreditation.

(b) A private mental health institution must notify the division, in writing, within ten (10) working days after any of the following:

(1) Change in the accreditation status of the private mental health institution.

(2) Change in the president of the governing board.

(3) Change in the chief executive officer of the private mental health institution.

(4) Unannounced accreditation surveys.

(5) The initiation of bankruptcy proceedings.

(6) Adverse action against the entity as the result of the violation of health, fire, or safety codes as prescribed by federal, state, or local law.

(7) Documented violation of the rights of an individual being treated in the private mental health institution under IC 12-27.

(*Division of Mental Health and Addiction; 440 IAC 1.5-2-5*)

### 440 IAC 1.5-2-6 Conditional licensure

Authority: IC 12-8-8-4; IC 12-21-2-3; IC 12-25-1-2  
Affected: IC 12-25-2

Sec. 6. (a) The division shall change the licensure status of a private mental health institution to that of conditional licensure if the division determines that the private mental health institution has received conditional accreditation status.

(b) The division may change the licensure status of a private mental health institution to that of conditional licensure if the division determines that the private mental health institution no longer meet the requirements in this article.

(c) Within a conditional licensure period, the division may:

(1) require that the facility stop all new admissions;

(2) grant an extension of the conditional licensure;

(3) reinstate the regular license of the private mental health institution if the division requirements are met within the imposed deadline; or

(4) take action to suspend or revoke the entity's licensure as a private mental health institution if the division requirements are not met within the imposed deadline.

(d) The division shall notify the chief executive officer of the private mental health institution of the change in certification status in writing. The notice shall include the following:

(1) The standards not met and the actions the private mental health institution must take to meet those standards.

(2) The amount of time granted the private mental health institution to meet the required standard.

(3) Actions to be taken by the private mental health institution during the time period of the extension.

(e) The division has the discretion to determine the time period and frequency of a conditional licensure; however, a conditional licensure plus any extensions may not exceed twelve (12) months.

(f) Extension requirements shall include the following:

(1) If the division grants an extension of a conditional licensure, the division shall notify the private mental health institution in writing.

(2) The notice shall include the following:

(A) The time period of the extension.

(B) The standards not met and the actions the private mental health institution must take to meet those standards.

(C) Actions to be taken by the private mental health institution during the time period of the extension.

(g) If the private mental health institution does not attain the improvements required by the division within the period of time required, the division shall take action to suspend or revoke the private mental health institution's license in accordance with IC 12-25-2. (*Division of Mental Health and Addiction; 440 IAC 1.5-2-6*)

#### **440 IAC 1.5-2-7 Revocation of licensure**

Authority: IC 12-8-8-4; IC 12-21-2-3; IC 12-25-1-2

Affected: IC 12-25-2

Sec. 7. (a) The division may revoke the licensure issued under this article after the division's investigation and determination of the following:

(1) A substantive change in the operation of the private mental health institution, which, under the standards for accreditation, would cause the accrediting agency to revoke the accreditation.

(2) Failure of the private mental health institution to regain accreditation within ninety (90) days following expiration of the private mental health institution's current accreditation by the private mental health institution's accrediting agency.

(3) Failure to comply with this article.

(4) That the physical safety of the consumers or staff of the private mental health institution is compromised by a physical or sanitary condition of a physical facility of a private mental health institution.

(5) Violation of a federal, state, or local statute, ordinance, rule, or regulation in the course of the operation of the private mental health institution that endangers the health, safety, or continuity of services to consumers.

(6) The private mental health institution or its corporate owner files for bankruptcy.

(b) To revoke a license, the director shall follow the requirements in IC 12-25-2.

(c) If the division revokes an entity's licensure as a private mental health institution, the entity may not continue to operate.

(d) If the division revokes an entity's licensure as a private mental health institution, the entity may not reapply

to become a private mental health institution until a lapse of twelve (12) months from the date of the revocation. (*Division of Mental Health and Addiction; 440 IAC 1.5-2-7*)

#### **440 IAC 1.5-2-8 Appeal rights**

Authority: IC 12-21-2-3; IC 12-25-1-2

Affected: IC 12-25-3

Sec. 8. A private mental health institution that is aggrieved by any adverse action taken under this rule may appeal the action under IC 12-25-3. (*Division of Mental Health and Addiction; 440 IAC 1.5-2-8*)

### **Rule 3. Organizational Standards and Requirements**

#### **440 IAC 1.5-3-1 Governing board**

Authority: IC 12-8-8-4; IC 12-21-2-3; IC 12-25-1-2

Affected: IC 12-25

Sec. 1. (a) The private mental health institution shall have a governing board.

(b) The purpose of the governing board is to make policy and to assure the effective implementation of the policy.

(c) The duties of the governing board include the following:

(1) Meet on a regular basis.

(2) Employ a chief executive officer for the private mental health institution who is delegated the authority and responsibility for managing the private mental health institution.

(3) Delineate in writing the responsibility and authority of the chief executive officer.

(4) Ensure that all workers, including contract and agency personnel, for whom a license, registration, or certification is required, maintain current license, registration, or certification and keep documentation of same so that it can be made available within a reasonable period of time.

(5) Ensure that orientation and training programs are provided to all employees and that each employee has a periodic performance evaluation that includes competency evaluation and an individualized education plan.

(6) Evaluate the performance of the chief executive officer. Evaluations must be conducted every other year, at a minimum.

(7) Establish and enforce prudent business and fiscal policies for the private mental health institution.

(8) Develop and enforce written policies governing private mental health institution operations.

(9) Develop and implement an ongoing strategic plan that identifies the priorities of the governing board and considers community input and consumer assessment of programs and services offered.

(10) Assure that minutes of all meetings are maintained and accurately reflect the actions taken.

(11) Conduct an annual assessment that includes the following:

## Proposed Rules

(A) A review of the business practices of the private mental health institution to ensure that:

- (i) appropriate risk management procedures are in place;
- (ii) prudent financial practices occur; and
- (iii) professional practices are maintained in regard to information systems, accounts receivable, and accounts payable.

A plan of corrective action shall be implemented for any identified deficiencies in the private mental health institution's business practices.

(B) A review of the programs of the private mental health institution, assessing whether the programs are well utilized, cost effective, and clinically effective. A plan of corrective action shall be implemented for any identified deficiencies in the private mental health institution's current program practices.

(d) The governing board is responsible for the conduct of the medical or professional staff. The governing board shall do the following:

(1) Determine, with the advice and recommendation of the medical or professional staff, and in accordance with state law, which categories of practitioners are eligible candidates for appointment to the medical or professional staff.

(2) Ensure that:

(A) the requests of practitioners, for appointment or reappointment to practice in the private mental health institution, are acted upon, with the advice and recommendation of the medical or professional staff;

(B) reappointments are acted upon at least biennially;

(C) practitioners are granted privileges consistent with their individual training, experience, and other qualifications; and

(D) this process occurs within a reasonable period of time, as specified by the medical or professional staff bylaws.

(3) Ensure that the medical or professional staff has approved bylaws and rules and that the bylaws and rules are reviewed and approved at least triennially. Governing board approval of medical or professional staff bylaws and rules shall not be unreasonably withheld.

(4) Ensure that the medical or professional staff is accountable and responsible to the governing board for the quality of care provided to consumers.

(5) Ensure that criteria for selection for medical or professional staff membership are individual character, competence, education, training, experience, and judgment.

(6) Ensure that the granting of medical or professional staff membership or professional privileges in the private mental health institution is not solely dependent upon certification, fellowship, or membership in a specialty body or society.

*(Division of Mental Health and Addiction; 440 IAC 1.5-3-1)*

### 440 IAC 1.5-3-2 Medical or professional staff organization

Authority: IC 12-8-8-4; IC 12-21-2-3; IC 12-25-1-2

Affected: IC 12-25

Sec. 2. (a) There shall be a single organized medical or professional staff that has the overall responsibility for the quality of all clinical care provided to consumers and for the professional practices of its members as well as for accounting to the governing board.

(b) The appointment and reappointment of medical or professional staff shall be based on well-defined, written criteria whereby it can satisfactorily be determined that the individual is appropriately licensed, certified, registered, or experienced and is qualified for privileges and responsibilities sought.

(c) Clinical privileges shall be facility specific and based on an individual's demonstrated current competency.

(d) The facility shall provide clinical supervision when required or indicated.

(e) There shall be a physician on call twenty-four (24) hours a day.

(f) The private mental health institution shall have on staff a medical services director who:

(1) has responsibility for the oversight and provision of all medical services; and

(2) is a physician licensed to practice medicine in Indiana.  
*(Division of Mental Health and Addiction; 440 IAC 1.5-3-2)*

### 440 IAC 1.5-3-3 Quality assessment and improvement

Authority: IC 12-8-8-4; IC 12-21-2-3; IC 12-25-1-2

Affected: IC 12-25

Sec. 3. (a) The facility shall establish a planned, systematic, organizational approach to process design, performance, analysis, and improvement. The plan must be interdisciplinary and involve all areas of the facility. Performance expectations shall be established, measured, aggregated, and analyzed on an ongoing basis, comparing performance over time and with other sources. Through this process, the facility identifies changes that will lead to improved performance that is achieved and sustained and reduce the risk of sentinel events.

(b) The process analyzes and makes necessary improvements to the following:

(1) All services, including service by contractor.

(2) All functions, including, but not limited to, the following:

(A) Discharge and transfer.

(B) Infection control.

(C) Medication use.

(D) Response to emergencies.

(E) Restraint and seclusion.

(F) Consumer injury.

(G) Staff injury.

(H) Any other areas that are high risk, problem prone, or high volume incidents.

(3) All medical and treatment services performed in the facility with regard to appropriateness of diagnosis and treatments related to a standard of care and anticipated or expected outcomes.

(c) The facility shall take appropriate action to address the opportunities for improvement found through the quality assessment and improvement plan, and:

(1) the action shall be documented; and

(2) the outcome of the action shall be documented as to its effectiveness, continued follow-up, and impact on consumer care.

*(Division of Mental Health and Addiction; 440 IAC 1.5-3-3)*

#### **440 IAC 1.5-3-4 Dietetic services**

Authority: IC 12-8-8-4; IC 12-21-2-3; IC 12-25-1-2

Affected: IC 12-25

Sec. 4. (a) The private mental health institution shall have organized food and dietary services that are directed and staffed by adequate, qualified personnel, or a contract with an outside food management company that meets the minimum standards specified in this section.

(b) The food and dietetic service shall have the following:

(1) A full-time employee who:

(A) serves as director of the food and dietetic services; and

(B) is responsible for the daily management of the dietary services.

(2) A registered dietitian, full time, part time, or on a consulting basis. If a consultant is used, he or she shall:

(A) submit periodic written reports on the dietary services provided;

(B) provide the number of on-site dietitian hours commensurate with the:

(i) type of dietary supervision required;

(ii) bed capacity; and

(iii) complexity of the consumer care services;

(C) complete nutritional assessments; and

(D) approve menus.

(3) Administrative and technical personnel competent in their respective duties.

(c) The dietary service shall do the following:

(1) Provide for liaison with the private mental health institution medical or professional staff for recommendations on dietetic policies affecting consumer treatment.

(2) Correlate and integrate dietary care functions with those of other consumer care personnel that include, but are not limited to, the following:

(A) Consumer nutritional assessment and intervention.

(B) Recording pertinent information on the consumer's chart.

(C) Conferring with and sharing specialized knowledge with other members of the consumer care team.

(d) Menus shall meet the needs of the consumers as follows:

(1) Therapeutic diets shall be prescribed by the practitioner responsible for the care of the consumer.

(2) Nutritional needs shall be met in accordance with recognized dietary standards of practice and in accordance with the orders of the responsible practitioner.

(3) A current therapeutic diet manual approved by the dietitian and medical or professional staff shall be readily available to all medical, nursing, and food service personnel.

(4) Menus shall be followed and posted in the food preparation and serving area.

(5) Menus served shall be maintained on file for at least thirty (30) days.

*(Division of Mental Health and Addiction; 440 IAC 1.5-3-4)*

#### **440 IAC 1.5-3-5 Infection control**

Authority: IC 12-8-8-4; IC 12-21-2-3; IC 12-25-1-2

Affected: IC 12-25

Sec. 5. (a) The facility shall provide a safe and healthful environment that minimizes infection exposure and risk to consumer, health care workers, and visitors. This is completed in a coordinated process that recognizes the risk of the endemic and epidemic nosocomial infections.

(b) There shall be an active, effective written facility-wide infection control program. Included in the program shall be a system designed for the identification, surveillance, investigation, control, reporting of information (internally and to health agencies), and prevention of infection and communicable diseases in the consumer and health care worker.

(c) The infection control program shall have a method for identifying and evaluating trends or clusters of nosocomial infections or communicable diseases. The infection control process involves universal precautions and other activities aimed at preventing the transmission of communicable diseases significant between consumer and health care workers.

(d) The facility shall have as part of the infection control program a needlestick prevention and exposure plan.

(e) A person, who has the support of facility management and is qualified by training or experience, shall be designated as responsible for the ongoing infection control activities and the development and implementation of the policies governing the control of infection and the communicable diseases.

(f) The facility shall have a functioning infection control

## Proposed Rules

committee that includes the individual responsible for the infection control program, a member of the medical or professional staff, a representative from nursing staff, and other appropriate individuals as needed. The committee will be met quarterly and minutes of meeting will be taken.

(g) The duties of the committee include the following:

- (1) Writing policies and procedures in regard to sanitation, universal precautions, cleaning, disinfection, aseptic technique, linen management, employee health, personal hygiene, and attire.
- (2) Assuring the system complies with state and federal laws to monitor the immune status of consumers and staff exposed to communicable diseases.

(h) Facility management shall be responsible to assure implementation and corrective actions as necessary to ensure that infection control policies are followed.

(i) Management shall provide appropriate infection control input into plans during any renovation or construction. (*Division of Mental Health and Addiction; 440 IAC 1.5-3-5*)

### 440 IAC 1.5-3-6 Medical record services

Authority: IC 12-8-8-4; IC 12-21-2-3; IC 12-25-1-2

Affected: IC 12-25

Sec. 6. (a) The facility shall maintain a written clinical record on every consumer and shall have policies and procedures for clinical record organization and content.

(b) The services must be directed by a registered health information administrator (RHIA) or an accredited health information technician (RHIT). If a full-time or part-time RHIA or RHIT is not employed, then a consultant RHIA or RHIT must be provided to assist the person in charge. Documentation of the findings and recommendations of the consultant must be maintained.

(c) The unit record system shall be used to assure that the maximum possible information about a consumer is available. The consumer's record shall contain pertinent information, which, at a minimum, shall consist of the following:

- (1) Face sheet (identification data).
- (2) Referral information.
- (3) Data base (assessment information).
- (4) Individual treatment plan.
- (5) History and physical exams.
- (6) Physician's or licensed mental health professional's orders.
- (7) Medication and treatment record.
- (8) Progress notes.
- (9) Treatment plan reviews.
- (10) Special dietetic information.
- (11) Consultation reports.

(12) Correspondence.

(13) Legal/commitment papers.

(14) Discharge/separation summary.

(15) Release/aftercare plans.

(d) The record shall contain identifying data in accordance with the policy of the facility.

(e) The consumer record shall contain information of any unusual occurrences, such as the following:

(1) Treatment complications.

(2) Accidents or injuries to the consumer.

(3) Morbidity.

(4) Death of a consumer.

(5) Procedures that place a consumer at risk or cause unusual pain.

(f) All entries in the consumer record shall be signed and dated.

(g) Symbols and abbreviations shall be used only if they have been approved by the medical or professional staff and only when there is an explanatory legend and shall not be used in the recording of a diagnosis.

(h) The facility shall be responsible to:

- (1) maintain, control, and supervise consumer records; and
- (2) maintain quality.

(i) The consumer record service shall establish, maintain, and control record completeness systems and mechanisms to ensure the quality and appropriateness of all documentation.

(j) Written policies and procedures shall govern the compilation, storage, dissemination, and accessibility of consumer records and be so designed as to assure that the facility fulfills its responsibility to protect the records against loss, unauthorized alteration, or disclosure of information.

(k) The consumer record shall be considered both a medical and legal document with careful consideration given to each entry in advance; therefore, the record may not be changed unless an error has been made or omission discovered with the correction process identified by policy and procedure.

(l) The facility shall maintain an indexing or referencing system that can be used to locate a consumer record that has been removed from the central file area.

(m) The facility shall have written policies and procedures that protect the confidentiality of consumer records and govern the disclosure of information in the records. The record shall comply with all applicable federal, state, and local laws, rules, and regulations.



(n) All original medical records or legally reproduced medical records must be maintained by the facility for a period of seven (7) years, must be readily accessible, in accordance with the facility policy, and must be kept in a fire resistive structure. (*Division of Mental Health and Addiction; 440 IAC 1.5-3-6*)

**440 IAC 1.5-3-7 Nursing service**

Authority: IC 12-8-8-4; IC 12-21-2-3; IC 12-25-1-2  
 Affected: IC 12-25

Sec. 7. (a) The private mental health institution shall have an organized nursing service led by a nurse executive, who has the authority and responsibility to ensure that the nursing standards of consumer care, and standards of nursing practice are consistent with professional standards. The nursing executive or designee shall approve all nursing policies, procedures, nursing standards of consumer care and standards of nursing practice. The nurse executive is also responsible for determining number and type of nursing personnel needed as well as maintaining a nursing organizational chart and job description for all positions. The nurse executive participates with leaders of the governing body, management and medical or professional staff, and other clinical areas in planning and promoting and conducting organizational wide performance improvement activities.

(b) The private mental health institution shall have an organized nursing service that provides twenty-four (24) hour nursing services furnished or supervised by a registered nurse.

(c) The service shall have an organized plan that delineates the responsibilities for consumer care, which includes monitoring of each consumer's status and coordinates the provision of nursing care while assisting other professional implementing their plans of care.

(d) The nursing service shall have the following:

(1) Adequate numbers of licensed registered nurses and licensed practical nurses for the provision of appropriate care to all consumers which may include assessing consumer nursing needs, planning, and providing nursing care interventions, preventing complications, providing and improving on consumer comfort and wellness.

(2) The service shall have a procedure to ensure that private mental health institution nursing personnel, including nurse registry personnel for whom licensure is required, have valid and current licensure.

(e) All nursing personnel shall demonstrate and document competency in fulfilling their assigned responsibilities. (*Division of Mental Health and Addiction; 440 IAC 1.5-3-7*)

**440 IAC 1.5-3-8 Physical plant; maintenance and environmental services**

Authority: IC 12-8-8-4; IC 12-21-2-3; IC 12-25-1-2  
 Affected: IC 12-25

Sec. 8. (a) The private mental health institution shall be constructed, arranged, and maintained to ensure the safety of the consumer and to provide facilities for services authorized under the private mental health institution license as follows:

(1) The plant operations and maintenance service, equipment maintenance, and environmental service shall be:

(A) staffed to meet the scope of the services provided; and  
 (B) under the direction of a person or persons qualified by education, training, or experience.

(2) There shall be a safety officer designated to assume responsibility for the safety program.

(3) The facility shall provide a physical plant and equipment that meets the statutory requirements and regulatory provisions of the rules of the fire prevention and building safety commission, including 675 IAC 22, Indiana fire codes, and 675 IAC 13, Indiana building codes.

(b) The condition of the physical plant and the overall environment shall be developed and maintained in such a manner that the safety and well being of consumers are assured as follows:

(1) No condition in the facility or on the grounds shall be maintained that may be conducive to the harborage or breeding of insects, rodents, or other vermin.

(2) No condition shall be created or maintained which may result in a hazard to consumers, public, or employees.

(3) There shall be a plan for emergency fuel and water supply.

(4) Provision shall be made for the periodic inspection, preventive maintenance, and repair of the physical plant and equipment by qualified personnel as follows:

(A) Operation, maintenance, and spare parts manuals shall be available, along with training or instruction of the appropriate personnel, in the maintenance and operation of the fixed and movable equipment.

(B) Operational and maintenance control records shall be established and analyzed periodically. These records shall be readily available on the premises.

(C) Maintenance and repairs shall be carried out in accordance with applicable codes, rules, standards, and requirements of local jurisdictions, the administrative building council, the state fire marshal, and the Indiana state department of health.

(c) In new construction, renovations, and additions, the facilities shall meet the following:

(1) The 2001 edition of the national "Guideline for Construction and Equipment of Private mental health institution and Medical Facilities" (Guidelines).

(2) All building, fire safety, and handicapped accessibility codes and rules adopted by the fire prevention and building safety commission shall apply to all facilities covered by this rule and take precedence over any

## Proposed Rules

building, fire safety, or handicapped accessibility requirements of the Guidelines.

(3) When renovation or replacement work is done within an existing facility, all new work or addition, or both, shall comply, insofar as practical, with applicable sections of the Guidelines and for certification with appropriate parts of National Fire Protection Association (NFPA) 101 and the applicable rules of the fire prevention and building safety commission.

(4) Proposed sites shall be located away from detrimental nuisances, well drained, and not subject to flooding. A site survey and recommendations shall be obtained from the department of health prior to site development.

(5) Water supply and sewage disposal services shall be obtained from municipal or community services. Outpatient facilities caring for consumers less than twenty-four (24) hours that do not provide surgery, laboratory, or renal dialysis services may be served by approved private on-site septic tank absorption field systems.

(6) Site utility installations for water, sprinkler, sanitary, and storm sewer systems, and wells for potable emergency water supplies shall comply with applicable sections of Bulletin S.E. 13, "On-Site Water Supply and Wastewater Disposal for Public and Commercial Establishments", 1988 edition.

(7) As early in the construction, addition, or renovation project as possible, the functional and operational description shall be submitted to the division. This submission shall consist of, but not be limited to, the following:

(A) Functional program narrative as established in the Guidelines.

(B) Schematics, based upon the functional program, consisting of drawings (as single-line plans), outline specifications, and other documents illustrating the scale and relationship of project components.

(8) Prior to the start of construction, addition, and/or renovation projects, detailed architectural and operational plans for construction shall be submitted to the plan review division of the department of fire and building services and to the division of sanitary engineering of the Indiana state department of health as follows:

(A) Working drawings, project manual, and specifications shall be included.

(B) Prior to submission of final plans and specifications, recognized standards, and codes, including infection control standards, shall be reviewed as required in section 2(f)(2) of this rule.

(C) All required construction design releases shall be obtained from the state building commissioner and final approval from the division of sanitary engineering of the Indiana state department of health prior to issuance of the occupancy letter by the division.

(9) All back flow prevention devices shall be installed as required by 327 IAC 8-10 and the current edition of the

Indiana plumbing code. Such devices shall be listed as approved by the Indiana state department of health.

(10) Upon receipt of a construction design release from the state building commissioner and documentation of a completed plan review by the division of sanitary engineering of the Indiana state department of health, a licensure application shall be submitted to the division on the form approved and provided by the division.

(d) The equipment requirements are as follows:

(1) All equipment shall be in good working order and regularly serviced and maintained.

(2) There shall be sufficient equipment and space to assure the safe, effective, and timely provision of the available services to consumers as follows:

(A) All mechanical equipment (pneumatic, electric, or other) shall be on a documented maintenance schedule of appropriate frequency and with the manufacturer's recommended maintenance schedule.

(B) There shall be evidence of preventive maintenance on all equipment.

(C) Appropriate records shall be kept pertaining to equipment maintenance, repairs, and current leakage checks.

(3) Defibrillators shall be discharged at least in accordance with manufacturers recommendations and a discharge log with initialed entries shall be maintained.

(4) Electrical safety shall be practiced in all areas.

(e) The building or buildings, including fixtures, walls, floors, ceiling, and furnishings throughout, shall be kept clean and orderly in accordance with current standards of practice as follows:

(1) Environmental services shall be provided in such a way as to guard against transmission of disease to consumers, health care workers, the public, and visitors by using the current principles of:

(A) asepsis;

(B) cross-infection; and

(C) safe practice.

(2) Refuse and garbage shall be collected, transported, sorted, and disposed of by methods that will minimize nuisances or hazards.

(f) The safety management program shall include, but not be limited to, the following:

(1) An ongoing facility-wide process to evaluate and collect information about hazards and safety practices to be reviewed by the safety committee.

(2) A safety committee appointed by the chief executive officer that includes representatives from administration, consumer services, and support services.

(3) The safety program that includes, but is not limited to, the following:

(A) Consumer safety.

(B) Health care worker safety.

- (C) Public and visitor safety.
- (D) Hazardous materials and wastes management in accordance with federal and state rules.
- (E) A written fire control plan that contains provisions for the following:
  - (i) Prompt reporting of fires, as required under the provisions of the Indiana Fire Code.
  - (ii) Extinguishing of fires.
  - (iii) Protection of consumers, personnel, and guests.
  - (iv) Evacuation.
  - (v) Cooperation with firefighting authorities.
- (F) Maintenance of written evidence of regular inspection and approval by state or local fire control agencies.
- (G) Emergency and disaster preparedness coordinated with appropriate community, state, and federal agencies.

*(Division of Mental Health and Addiction; 440 IAC 1.5-3-8)*

#### **440 IAC 1.5-3-9 Intake and treatment**

Authority: IC 12-8-8-4; IC 12-21-2-3; IC 12-25-1-2  
Affected: IC 12-25

**Sec. 9. (a)** The facility shall have policies and procedures that govern the intake and assessment process to determine eligibility for services.

**(b)** Treatment required by the consumer shall be appropriate to the facility and the professional expertise of the staff.

**(c)** Alternatives for less intensive and restrictive treatment are not available in the community.

**(d)** A physical examination shall be completed by a licensed physician, an advanced practice nurse, or physician's assistant within twenty-four (24) hours after admission.

**(e)** An initial emotional, behavioral, social, and legal assessment of each consumer shall be completed upon admission.

**(f)** When the admitted consumer is a child or adolescent under eighteen (18) years of age, then the initial assessment shall also include an evaluation of school progress, a report of involvement with other social/legal services agencies, and an assessment of family functioning and relationships. Family input and advice shall be considered in the diagnosis, treatment planning, and discharge planning process.

**(g)** A child (fourteen (14) years of age and under) may be admitted to a nonsegregated unit (adult unit) only under an emergency situation. The criteria for such an emergency admission must be specified in advance and must include plans for an evaluation by a child psychiatrist within sixty (60) hours of admission.

**(h)** An admission under subsection (h) shall be verbally

reported to the division within twenty-four (24) hours of the admission. A written report shall be submitted to the division within ten (10) working days.

**(i)** A preliminary treatment plan shall be formulated within sixty (60) hours of admission on the basis of the intake assessment done at the time of admission.

**(j)** Consumers shall participate in the development and review of their own treatment plans. If the consumer agrees to family participation and signs a release of information, the facility shall consider input from and participate with the family in the diagnosis and treatment process.

**(k)** If a consumer chooses not to participate in the treatment planning process, it shall be documented in the clinical record.

**(l)** The treatment plan shall specify the services necessary to meet the consumer's needs and shall contain discharge or release criteria and the discharge plan.

**(m)** Progress notes shall be entered daily in the consumer's record by staff having knowledge of the consumer and responsibility for implementing the treatment plan. The notes from all sources shall be entered in an integrated chronological order in the record, signed, and dated.

**(n)** At a minimum of every seven (7) days, the treatment plan shall be reviewed and revised as necessary. *(Division of Mental Health and Addiction; 440 IAC 1.5-3-9)*

#### **440 IAC 1.5-3-10 Discharge planning services**

Authority: IC 12-8-8-4; IC 12-21-2-3; IC 12-25-1-2  
Affected: IC 12-25

**Sec. 10.** To facilitate discharge as soon as an inpatient level of care is no longer required, the private mental health institution shall have effective, ongoing discharge planning initiated at admission that does the following:

**(1)** Facilitates the provision of follow-up care.

**(2)** Transfers or refers consumers, along with necessary medical information and records, to appropriate facilities, agencies, or outpatient services, as needed, for follow-up or ancillary care. The information shall include, but not be limited to, the following:

**(A)** Medical history.

**(B)** Current medications.

**(C)** Available social, psychological, and educational services to meet the needs of the consumer.

**(D)** Nutritional needs.

**(E)** Outpatient service needs.

**(F)** Follow-up care needs.

**(3)** Utilizes available community and private mental health institution resources to provide appropriate referrals or make available social, psychological, and

## Proposed Rules

educational services to meet the needs of the consumer.  
(Division of Mental Health and Addiction; 440 IAC 1.5-3-10)

### 440 IAC 1.5-3-11 Pharmacy services

Authority: IC 12-8-8-4; IC 12-21-2-3; IC 12-25-1-2  
Affected: IC 12-25

Sec. 11. The private mental health institution shall have a pharmacy service that ensures that medication use processes are organized and systematic throughout the private mental health institution. The following requirements apply:

- (1) The organization shall identify an appropriate selection or formulary of medications available for prescribing or ordering.
- (2) The private mental health institution shall address prescribing or ordering and procuring of medications not available within the formulary.
- (3) Policies and procedures shall be in place to support safe medication prescription ordering and storage, and address such issues as pain management medication and PRN medications.
- (4) The preparation and dispensing of medication(s) shall adhere to law, regulation, licensure, and professional standards of practice.
- (5) The preparation and dispensing of medication(s) is appropriately controlled.
  - (A) There shall be an individual patient dose system in place.
  - (B) A pharmacist shall review all medication prescriptions or orders, including reviewing for interactions and adverse effects.
  - (C) There shall be a system in place for considering important consumer medication information when a medication(s) is prepared and dispensed for a consumer.
  - (D) There shall be a procedure in place for pharmacy service availability at any times when the pharmacy is closed or otherwise unavailable.
  - (E) Emergency medications shall be consistently available, controlled, and secure in the pharmacy and consumer care areas.
  - (F) There shall be a medication recall system providing for the retrieval and safe disposal of discontinued and recalled medications.
- (6) There shall be a system in place to insure that prescriptions or orders are verified and consumers are properly identified before any medication is administered or dispensed.
- (7) Any investigational medication(s) shall be safely controlled and administered during experimental trials, and safely destroyed at the conclusion of any such investigational trial.
- (8) There shall be a written policy in place that assures the routine inspection of the storage of all medications.

(9) There shall be a written system in place to address appropriate storage and dispensing of sample medications.

(Division of Mental Health and Addiction; 440 IAC 1.5-3-11)

### 440 IAC 1.5-3-12 Plan for special procedures

Authority: IC 12-8-8-4; IC 12-21-2-3; IC 12-25-1-2  
Affected: IC 12-25

Sec. 12. (a) The facility shall have policies and a written plan in place that shall include clinical justification for any of the following special procedures:

- (1) The use of restraint or seclusion or both.
  - (2) The use electro-convulsive therapy.
  - (3) The use of investigational and experimental drugs.
- (b) If any procedure in this section is utilized, the rationale for the use shall be clearly stated in the consumer record.
- (c) The use of restraint or seclusion shall be limited through plans, priorities, human resource planning, staff orientation and education, assessment process that identify and prevent behavioral risk factors. The process shall involve the consumer and, with the consent of the consumer, the family.
- (d) Restraint or seclusion use within the facility is limited to incidents and those situations, with adequate appropriate clinical justification, that are required due to dangerousness to the consumer or others.
- (e) The use of restraint or seclusion shall be utilized using the least restrictive alternative.
- (f) A licensed independent practitioner shall conduct a clinical assessment of the consumer prior to writing an order for seclusion or restraint or within one (1) hour of the initiation of the seclusion or restraint.
- (g) The licensed independent practitioner's orders should be limited to four (4) hours for individuals eighteen (18) years of age and older, two (2) hours for individuals nine (9) years of age through seventeen (17) years of age and one (1) hour for individuals under the nine (9) years of age. The orders shall contain behavioral criteria for release.
- (h) In an emergency, restraint or seclusion, or both, may only be utilized by trained, clinically privileged staff, and shall be documented in the consumer's record and an order obtained. The licensed independent practitioner must complete a face-to-face evaluation in within one (1) hour.
- (i) PRN orders shall not be used to authorize seclusion or restraint.
- (j) A consumer in restraint or seclusion shall be assessed

and monitored continuously through face-to-face observation by an assigned staff member who is trained in correct procedures and competent.

(k) After the first hour, an individual in seclusion only may be monitored by video and audio equipment.

(l) If the individual is put in a physical hold a second staff member shall be assigned to observe.

(m) Documentation shall occur every fifteen (15) minutes in the consumer's record, consistent with the organizational policies.

(n) The use of restraint and seclusion shall be discontinued when the individual meets the behavior criteria set forth in the orders.

(o) Staff and the consumer will participate in debriefing about the restraint and seclusion episode.

(p) The organization shall collect data on the use of restraint and seclusion in order to monitor and improve its performance.

(q) When electro-convulsive therapy or investigational or experimental drugs are used, the written informed consent of the consumer or legal guardian shall be obtained. The consumer or legal guardian may withdraw consent at any time.

(r) The facility shall comply with all federal regulations regarding any of the following special procedures:

(1) The use of restraint or seclusion, or both.

(2) The use electro-convulsive therapy.

(3) The use of investigational and experimental drugs.

*(Division of Mental Health and Addiction; 440 IAC 1.5-3-12)*

SECTION 2. 440 IAC 1-1.5 IS REPEALED.

#### **Notice of Public Hearing**

*Under IC 4-22-2-24, notice is hereby given that on July 24, 2002 at 10:00 a.m., at the Indiana Government Center-South, 402 West Washington Street, Conference Center Room 6, Indianapolis, Indiana the Division of Mental Health and Addiction will hold a public hearing on a proposed rule concerning the licensure of private mental health institutions. Copies of these rules are now on file at the Indiana Government Center-South, 402 West Washington Street, Room W451 and Legislative Services Agency, One North Capitol, Suite 325, Indianapolis, Indiana and are open for public inspection.*

Janet Corson  
Director  
Division of Mental Health and Addiction

## **TITLE 440 DIVISION OF MENTAL HEALTH AND ADDICTION**

**Proposed Rule**  
LSA Document #02-105

### **DIGEST**

Amends 440 IAC 5-1-1, 440 IAC 5-1-2, and 440 IAC 5-1-3.5 concerning community care for individuals who are discharged or transferred from state institutions administered by the division of mental health and addiction, to clarify the gatekeeper's role regarding an individual's entry into and discharge from a state institution. Effective 30 days after filing with the secretary of state.

**440 IAC 5-1-1**

**440 IAC 5-1-2**

**440 IAC 5-1-3.5**

SECTION 1. 440 IAC 5-1-1 IS AMENDED TO READ AS FOLLOWS:

#### **440 IAC 5-1-1 Applicability**

Authority: IC 12-8-8-4

Affected: IC 11-10-4; IC 12-7-2-61; IC 12-23-7; IC 12-23-8; IC 12-24-19; IC 12-26; IC 35-36-2-4; IC 35-36-3; IC 35-41-1

Sec. 1. (a) This rule applies only to a patient who is transferred or discharged from a state institution administered by the division of mental health after the effective date of this rule.

(b) This rule does not apply to any of the following:

(1) An individual who is admitted to a state institution only for evaluation purposes.

(2) An individual who is incompetent to stand trial ~~and who is not civilly committed under IC 35-36-3.~~

(3) An individual who is found to be not guilty by reason of insanity under IC 35-36-2-4 and is subject to a civil commitment under IC 12-26.

(4) An individual who is immediately subject to a civil commitment upon the individual's release from incarceration in a facility administered by the department of correction or the Federal Bureau of Prisons, or upon being charged with or convicted of a forcible felony under IC 35-41-1.

(5) An individual placed under the supervision of the division for addictions treatment under IC 12-23-7 and IC 12-23-8.

(6) An individual transferred from the department of correction under IC 11-10-4.

~~(7)~~ (7) An individual who has a developmental disability as defined in IC 12-7-2-61.

~~(8)~~ (8) An individual in an alcohol and drug services program who is not concurrently diagnosed as mentally ill.

~~(9)~~ (9) An individual who has escaped from the facility to which the individual was involuntarily committed.

## Proposed Rules

~~(6)~~ (10) An individual who was admitted to a state institution for voluntary treatment and who has left the state institution against the advice of the attending physician.

*(Division of Mental Health and Addiction; 440 IAC 5-1-1; filed Jun 14, 1995, 11:00 a.m.: 18 IR 2777; readopted filed May 10, 2001, 2:30 p.m.: 24 IR 3235)*

SECTION 2. 440 IAC 5-1-2 IS AMENDED TO READ AS FOLLOWS:

### 440 IAC 5-1-2 Definitions

Authority: IC 12-8-8-4

Affected: IC 12-21-2-3; IC 12-21-2-7; IC 12-24-19; IC 12-26-6; IC 12-26-7; IC 23-17

Sec. 2. The following definitions apply throughout this rule:

(1) "Consumer" means a ~~patient an adult or an individual~~ **child** who has been discharged or transferred from a state institution administered by the division of mental health **and addiction to which the individual was admitted for voluntary treatment or was involuntarily committed.**

(2) "Discharged from a state institution" means the final and complete release of an individual with mental illness from the care, treatment, training, or detention at a state facility operated by the division of mental health **and addiction** to which the individual was admitted for voluntary treatment or was involuntarily committed. The term does not include an individual whose commitment is transferred to another state institution.

(3) "Discharged from commitment" means that the court has entered an order terminating a commitment on an individual.

(4) "Gatekeeper" means the following:

(A) The community mental health center which facilitated the consumer's entry into the state institution after July 1, 1994.

(B) For consumers who entered the state institution before July 1, 1994, the community mental health center which would have been designated to facilitate the consumer's entry into the state institution if the consumer had entered the institution after July 1, 1994.

(C) The community mental health center or managed care provider that agrees to accept the gatekeeper function for a particular patient when the original gatekeeper agrees to transfer that function and, when doing so, it is in the best interest of the consumer.

(5) "Managed care provider" means an organization:

(A) that:

(i) for mental health services, is defined under 42 U.S.C. 300x-2c; ~~or~~

(ii) provides addiction services; **or**

**(iii) provides children's mental health services;**

(B) that has entered into a provider agreement with the division of mental health **and addiction** under IC 12-21-2-7 to provide a continuum of care in the least restrictive, most appropriate setting; and

(C) that is operated by at least one (1) of the following:

(i) A city, town, county, or other political subdivision of Indiana.

(ii) An agency of Indiana or of the United States.

(iii) A political subdivision of another state.

(iv) A hospital owned or operated by:

(AA) a unit of government; or

(BB) a building authority that is organized for the purpose of constructing facilities to be leased to units of government.

(v) A corporation incorporated under IC 23-7-1.1 (before its repeal August 1, 1991) or IC 23-17.

~~(vi) A nonprofit corporation incorporated in another state.~~

**An organization that is exempt from federal income taxation under Section 501(c)(3) of the Internal Revenue Code.**

(vii) A university or college.

(6) "State institution" means a state facility operated by the division of mental health **and addiction.**

(7) "Transferred from a state institution" means the transfer of the commitment of an individual committed under IC 12-26-6 or IC 12-26-7 to a community mental health center or a health facility.

*(Division of Mental Health and Addiction; 440 IAC 5-1-2; filed Jun 14, 1995, 11:00 a.m.: 18 IR 2777; readopted filed May 10, 2001, 2:30 p.m.: 24 IR 3235)*

SECTION 3. 440 IAC 5-1-3.5 IS ADDED TO READ AS FOLLOWS:

### 440 IAC 5-1-3.5 Gatekeeper's role during the time the individual is in the state-operated facility

Authority: IC 12-8-8-4

Affected: IC 12-24-12; IC 12-24-19

Sec. 3.5. After an adult or child is admitted to a state-operated facility, the gatekeeper shall do the following:

(1) **Have a face-to-face meeting with the individual within thirty (30) days of admission and at least every ninety (90) days thereafter, to evaluate treatment progress, and discuss discharge planning.**

(2) **Communicate with the family or guardian of a child within thirty (30) days of admission and at least every ninety (90) days thereafter, to discuss the treatment plan, evaluate treatment progress, and discuss discharge planning.**

(3) **Communicate with the treatment team at the state-operated facility within thirty (30) days of admission and at least every ninety (90) days thereafter, to discuss the treatment plan, evaluate treatment progress and discuss discharge planning.**

(4) **Provide notice of the date for the planned community placement to the treatment team and the individual at least two (2) weeks prior to the anticipated community placement.**

(5) **Document face-to-face visits with the individual and**

**contact with the treatment team at the state-operated facility and in the gatekeeper's record.**

*(Division of Mental Health and Addiction; 440 IAC 5-1-3.5)*

**Notice of Public Hearing**

*Under IC 4-22-2-24, notice is hereby given that on July 24, 2002 at 9:00 a.m., at the Indiana Government Center-South, 402 West Washington Street, Conference Center Room 6, Indianapolis, Indiana the Division of Mental Health and Addiction will hold a public hearing on proposed amendments to clarify the gatekeeper's role regarding an individual's entry into and discharge from a state institution. Copies of these rules are now on file at the Indiana Government Center-South, 402 West Washington Street, Room W451 and Legislative Services Agency, One North Capitol, Suite 325, Indianapolis, Indiana and are open for public inspection.*

Janet Corson  
Director  
Division of Mental Health and Addiction

---

---

**TITLE 675 FIRE PREVENTION AND BUILDING SAFETY COMMISSION**

**Proposed Rule**  
LSA Document #02-115

**DIGEST**

Adds 675 IAC 13-2.4 to adopt and amend the 2000 International Building Code, third printing as the 2003 Indiana Building Code. Repeals 675 IAC 13-2.3. Effective 30 days after filing with the secretary of state.

**675 IAC 13-2.3**  
**675 IAC 13-2.4**

SECTION 1. 675 IAC 13-2.4 IS ADDED TO READ AS FOLLOWS:

**Rule 2.4. 2003 Indiana Building Code**

**675 IAC 13-2.4-1 Adoption by reference; title; availability; scope; purpose**

Authority: IC 22-13-2-2; IC 22-13-2-13  
Affected: IC 22-12; IC 22-13; IC 22-14; IC 22-15; IC 36-7

Sec. 1. (a) That certain document being titled the International Building Code, third printing, published by the International Code Council, 5203 Leesburg Pike, Suite 708, Falls Church, Virginia 22041-3401, is hereby adopted by reference as if fully set out in this rule save and except those revisions made in this rule.

(b) This rule is available for review and reference at the

Fire and Building Services Department, Indiana Government Center-South, 402 West Washington Street, Room W246, Indianapolis, Indiana 46204. *(Fire Prevention and Building Safety Commission; 675 IAC 13-2.4-1)*

**675 IAC 13-2.4-2 Chapter 1; administration**

Authority: IC 22-13-2-2; IC 22-13-2-13  
Affected: IC 4-21.5; IC 4-22-7-7; IC 22-12-7; IC 22-13-2-7; IC 22-13-5; IC 22-14; IC 22-15; IC 36-7

**Sec. 2. Delete Chapter 1 and substitute to read as follows:**

**Section 101 Application**

**101.1 Title**

This rule shall be known as the Indiana Building Code, 2003 edition and shall be published, except incorporated documents, by the fire and building services department, for general distribution and use under that title. Wherever the term "this code" is used throughout this rule, it shall mean the Indiana Building Code, 2003 edition.

**101.2 Scope and purpose**

The scope and purpose of this code is to establish the minimum requirements for the following:

1. Construction, addition, alteration, erection or assembly of any part of a Class 1 structure at the site where the structure will be used.
2. Installation of any part of the permanent heating, ventilating, air conditioning, electrical, plumbing, sanitary, emergency detection, emergency communication, or fire or explosion suppression systems for a Class 1 structure at the site where it will be used.
3. Work undertaken to alter, remodel, rehabilitate, or add to any part of a Class 1 structure.
4. Safeguarding life or property from the hazards of fire and explosion for Class 1 structures.
5. Fabrication of any part of a Class 1 industrialized building system for installation, assembly, or use at another site, except mobile structures.
6. Work undertaken to relocate any part of a Class 1 structure, except a mobile structure.
7. Assembly of a Class 1 industrialized building system that is not covered by subdivision 5, except mobile structures.
8. Detached one and two family dwellings and townhouses not more than three stories high and their accessory structures shall comply with the Indiana Residential Code, 675 IAC 14.

**101.3 Appendices and Standards**

Provisions in the appendices are not enforceable unless specifically adopted.

The codes and standards referenced in this code shall be

considered part of the requirements of this code to the prescribed extent of each such reference. Where differences occur between provisions of this code and referenced codes and standards, the provisions of this code shall apply.

**EXCEPTION:** Where enforcement of a code provision would violate the conditions of the listing, labeling or manufacturer's installation instructions of the equipment or appliance, the conditions of the listing, labeling or manufacturer's instructions shall apply.

### 101.4 Appeals and Interpretations

Appeals from orders issued by the Fire Prevention and Building Safety Commission, the Office of the State Building Commissioner or the Office of the State Fire Marshal are governed by IC 4-21.5 and IC 22-12-7. Appeals from orders by a local unit of government are governed by IC 22-13-2-7 and local ordinance. Upon the written request of an interested person who has a dispute with a county or municipal government concerning a building rule, the Office of the State Building Commissioner may issue a written interpretation of a building law. The written interpretation as issued under IC 22-13-5 binds the interested person and the county or municipality with whom the interested person has the dispute until overruled under IC 4-21.5. A written interpretation of a building law binds all counties and municipalities if the office of the state building commissioner publishes the written interpretation of the building law in the Indiana Register under IC 4-22.7-7(b).

### 101.5 Plans

Plans shall be submitted for Class 1 structures as required by the General Administrative Rules (675 IAC 12) and the Industrialized Building Systems (675 IAC 15).

### 101.6 Existing Construction

For existing Class 1 structures, see the General Administrative Rules (675 IAC 12) and local ordinance.

### 101.7 Additions and Alterations

Additions and alterations to any Class 1 structure shall conform to that required of a new structure without requiring the existing structure to comply with all the requirements of this code. Additions or alterations shall not cause an existing structure to become unsafe (See the General Administrative Rules (675 IAC 12-4)).

### 101.8 Alternate Materials, Methods, and Equipment

Alternate materials, methods, equipment, and design shall be as required by the General Administrative Rules (675 IAC 12-6-11) and the rules for Industrialized Building Systems (675 IAC 15). (*Fire Prevention and Building Safety Commission; 675 IAC 13-2.4-2*)

### 675 IAC 13-2.4-3 Section 202; definitions

Authority: IC 22-13-2-2; IC 22-13-2-13

Affected: IC 22-12-1-4; IC 22-13; IC 22-14; IC 22-15; IC 36-7

Sec. 3. In Section 202, make the following changes:

(1) Delete the definition of **AGRICULTURAL BUILDING**.  
(2) Delete the definition of **APPROVED** and substitute to read as follows:

**APPROVED** as to materials, equipment, design, and types of construction, acceptance by the building official by one (1) of the following methods:

(A) investigation or tests conducted by recognized authorities; or

(B) investigation or tests conducted by technical or scientific organizations; or accepted principles.

The investigation, tests or principles shall establish that the materials, equipment and types of construction are safe for their intended purpose.

(3) Delete the definition of **APPROVED AGENCY**.

(4) Delete the definition of **APPROVED FABRICATOR**.

(5) Delete the definition of **AREA OF REFUGE** and substitute to read as follows: See Chapter 11.

(6) Add the definition of **ASME A17.1** after the definition of **AREAWAY** to read as follows: **ASME A17.1**. See the Safety Code for Elevators, Escalators, Manlifts and Hoists (675 IAC 21).

(7) Delete the definition for **BUILDING OFFICIAL** and substitute to read as follows: **BUILDING OFFICIAL**. The Office of the State Building Commissioner authorized under IC 22-15-2-7; the Office of the State Fire Marshal authorized under IC 22-14-2-10; the local building official authorized under IC 36-7-9 and local ordinance; the fire department authorized under IC 36-8-17-9, or local ordinance.

(8) Add the definition of **CLASS 1 STRUCTURE** after the definition of **CLADDING** to read as follows: **CLASS 1 STRUCTURE**. See IC 22-12-1-4 and the General Administrative Rules (675 IAC 12).

(9) Add a definition of **CODE OFFICIAL** after the definition of **CLOSED SYSTEM** to read as follows: **CODE OFFICIAL**. See **BUILDING OFFICIAL**.

(10) Delete the definition of **CONSTRUCTION DOCUMENTS** and substitute to read as follows: **CONSTRUCTION DOCUMENTS**. See the General Administrative Rules (675 IAC 12) and the rules for Industrialized Building Systems (675 IAC 15).

(11) Delete the definition of **DETECTABLE WARNING**.

(12) Delete the following definitions: **DWELLING UNIT, GROUND FLOOR; DWELLING UNIT, MULTI-STORY; DWELLING UNIT, TYPE A; DWELLING UNIT, TYPE B**.

(13) Add the definition of **FIRE DEPARTMENT** to read as follows: **FIRE DEPARTMENT**. See **BUILDING OFFICIAL**.

(14) Delete the definition of **HISTORIC BUILDINGS**.



(15) Add the definition for ICC ELECTRICAL CODE after the definition of HURRICANE PRONE REGIONS to read as follows: ICC ELECTRICAL CODE. See the Indiana Electrical Code (675 IAC 17).

(16) Delete the definition of INSPECTION CERTIFICATE.

(17) Add the definition of INTERNATIONAL CODES after the definition of INTERLAYMENT to read as follows: INTERNATIONAL CODES. See Indiana Codes (675 IAC), Rules of the Fire Prevention and Building Safety Commission.

(18) Add a definition of International Building, Fire, Mechanical, Fuel Gas, Energy Conservation, Plumbing, and Residential Codes to read as follows: INTERNATIONAL BUILDING, FIRE, MECHANICAL, FUEL GAS, ENERGY CONSERVATION, PLUMBING, AND RESIDENTIAL CODES mean the INDIANA BUILDING, FIRE, MECHANICAL, FUEL GAS, ENERGY CONSERVATION, PLUMBING, AND RESIDENTIAL CODES.

(19) Delete the definition of JURISDICTION.

(20) Add the definition of NFPA after the definition of NATURALLY DURABLE WOOD to read as follows: NFPA. See Chapter 35 Referenced Standards.

(21) Delete the definition of PERMIT.

(22) Change the definition of REGISTERED DESIGN PROFESSIONAL to read as follows: REGISTERED DESIGN PROFESSIONAL. A registered architect or professional engineer who is registered under IC 25-4 or IC 25-31. If a registered design professional is not required by 675 IAC 12-6 or 675 IAC 15, then it means the owner.

(23) Delete the definition of REPAIR.

(24) Delete the definition of STRUCTURAL OBSERVATION.

(25) Add the definition of TOWNHOUSE after the definition of TIRES, BULK STORAGE OF to read as follows: TOWNHOUSE. A single family dwelling unit constructed in a row of attached units separated by property lines and with open space on at least two (2) sides, and is regulated by the Indiana Residential Code (675 IAC 14 as a Class 1 structure.

(26) Add the definition of TRAINED PERSONNEL after the definition of TOXIC to read as follows: TRAINED PERSONNEL. One who has undergone the instructions necessary to perform the duties required.

*(Fire Prevention and Building Safety Commission; 675 IAC 13-2.4-3)*

**675 IAC 13-2.4-4 Section 301.1 Scope**

Authority: IC 22-13-2-2; IC 22-13-2-13

Affected: IC 22-12; IC 22-13; IC 22-14; IC 22-15; IC 36-7

**Sec. 4.** Delete the words “buildings and” and substitute “Class 1”. *(Fire Prevention and Building Safety Commission; 675 IAC 13-2.4-4)*

**675 IAC 13-2.4-5 Table 302.1.1; incidental use area**

Authority: IC 22-13-2-2; IC 22-13-2-13

Affected: IC 22-12; IC 22-13; IC 22-14; IC 22-15; IC 36-7

**Sec. 5.** Change TABLE 302.1.1 INCIDENTAL USE AREAS as follows:

(1) Change in the SEPARATION column “2 hours”, that is across from “Automatic parking garage in other Group R-3” in the ROOM OR AREA column to read “2 hours or 1 hour and provide automatic fire-extinguishing system”.

(2) Change in the SEPARATION column “1 hour”, that is across from “Laundry rooms over 100 square feet” in the ROOM OR AREA column to read “1 hour or provide automatic fire-extinguishing system”.

(3) Change in the SEPARATION column “1 hour”, that is across from “Storage rooms over 100 square feet” in the ROOM OR AREA column to read “1 hour or provide automatic fire-extinguishing system”.

(4) In the ROOM OR AREA column, in the “Storage rooms over 110 square feet” add a superscript “b” after “feet” and after footnote “a” and at the bottom of the TABLE add footnote “b” to read as follows: b. See footnote b in TABLE 302.3.3 for exceptions to Groups B and M Occupancies.

*(Fire Prevention and Building Safety Commission; 675 IAC 13-2.4-5)*

**675 IAC 13-2.4-6 Section 302.3.2; nonseparated uses**

Authority: IC 22-13-2-2; IC 22-13-2-13

Affected: IC 22-12; IC 22-13; IC 22-14; IC 22-15; IC 36-7

**Sec. 6.** Add an Exception to end of Section 302.3.2 Nonseparated uses to read as follows: Exception: Unseparated Group A Occupancies shall be permitted within Group E Occupancies complying with the unlimited area provisions of Section 507.2 or Section 507.3. *(Fire Prevention and Building Safety Commission; 675 IAC 13-2.4-6)*

**675 IAC 13-2.4-7 Section 302.3.3; separated uses**

Authority: IC 22-13-2-2; IC 22-13-2-13

Affected: IC 22-12; IC 22-13; IC 22-14; IC 22-15; IC 36-7

**Sec. 7.** Change Exception 2 to Section 302.3.3 Separated uses as follows:

(1) In the second line change the word “be” to “by”.

(2) Add a sentence to the end of Exception 2 to read as follows: Garages beneath habitable rooms shall be separated from all habitable rooms above by not less than 5/8" Type X gypsum board or equivalent.

*(Fire Prevention and Building Safety Commission; 675 IAC 13-2.4-7)*

**675 IAC 13-2.4-8 TABLE 302.3.3; required separation of occupancies (hours)<sup>a</sup>**

Authority: IC 22-13-2-2; IC 22-13-2-13

Affected: IC 22-12; IC 22-13; IC 22-14; IC 22-15; IC 36-7

## Proposed Rules

**Sec. 8.** Change the title of TABLE 302.3.3 REQUIRED SEPARATION OF OCCUPANCIES (HOURS)<sup>a</sup> to read as follows: REQUIRED SEPARATION OF OCCUPANCIES (HOURS)<sup>a</sup> and REQUIRED SEPARATION BETWEEN FIRE AREAS WITHIN THE SAME OCCUPANCY CLASSIFICATION. (*Fire Prevention and Building Safety Commission; 675 IAC 13-2.4-8*)

**675 IAC 13-2.4-9** Section 303.1; assembly Group A

Authority: IC 22-13-2-2; IC 22-13-2-13

Affected: IC 22-12; IC 22-13; IC 22-14; IC 22-15; IC 36-7

**Sec. 9.** Change Section 303.1 ASSEMBLY GROUP A as follows:

(1) Add to the end of the A-1 use group the following: Symphony and concert halls.

(2) Add to the A-3 use group after the words "Dance halls" the words "not including food or drink consumption".

(3) Add to the end of A-4 use group the following: Gymnasiums.

(*Fire Prevention and Building Safety Commission; 675 IAC 13-2.4-9*)

**675 IAC 13-2.4-10** Section 307.2; definitions

Authority: IC 22-13-2-2; IC 22-13-2-13

Affected: IC 22-12; IC 22-13; IC 22-14; IC 22-15; IC 36-7

**Sec. 10.** In section 307.2, make the following changes:

(1) Delete in Section 307.2 Definitions, the last paragraph in the definition of HIGHLY TOXIC and substitute to read as follows: Mixtures of these materials with ordinary materials, such as water, might not warrant classification as highly toxic.

(2) Delete in Section 307.2 Definitions, in the definition of UNSTABLE (REACTIVE) MATERIAL Class 1 the word "which" after the word "can".

(*Fire Prevention and Building Safety Commission; 675 IAC 13-2.4-10*)

**675 IAC 13-2.4-11** Section 307.4; Group H-2 structures

Authority: IC 22-13-2-2; IC 22-13-2-13

Affected: IC 22-12; IC 22-13; IC 22-14; IC 22-15; IC 36-7

**Sec. 11.** Change in Section 307.4 "cryogenic liquids, flammable" to "cryogenic fluids, flammable". (*Fire Prevention and Building Safety Commission; 675 IAC 13-2.4-11*)

**675 IAC 13-2.4-12** Section 307.5; Group H-3 structures

Authority: IC 22-13-2-2; IC 22-13-2-13

Affected: IC 22-12; IC 22-13; IC 22-14; IC 22-15; IC 36-7

**Sec. 12.** Change in Section 307.5 "cryogenic liquids, oxidizing" to "cryogenic fluids, oxidizing". (*Fire Prevention and Building Safety Commission; 675 IAC 13-2.4-12*)

**675 IAC 13-2.4-13** Table 307.7(1); maximum allowable quantity per control area of hazardous materials posing a physical hazard<sup>a,j</sup>

Authority: IC 22-13-2-2; IC 22-13-2-13

Affected: IC 22-12; IC 22-13; IC 22-14; IC 22-15; IC 36-7

**Sec. 13.** Change in TABLE 307.7(1) MAXIMUM ALLOWABLE QUANTITY PER CONTROL AREA OF HAZARDOUS MATERIALS POSING A PHYSICAL HAZARD<sup>a,j</sup> the class for organic peroxide in the first row from "U<sup>d</sup>" to "UD". (*Fire Prevention and Building Safety Commission; 675 IAC 13-2.4-13*)

**675 IAC 13-2.4-14** Table 307.7(2); maximum allowable quantity per control area of hazardous material posing a health hazard<sup>a,b,c</sup>

Authority: IC 22-13-2-2; IC 22-13-2-13

Affected: IC 22-12; IC 22-13; IC 22-14; IC 22-15; IC 36-7

**Sec. 14.** Change in TABLE 307.7(2) MAXIMUM ALLOWABLE QUANTITY PER CONTROL AREA OF HAZARDOUS MATERIAL POSING A HEALTH HAZARD<sup>a,b,c</sup> the quantity for Highly toxic under "USE-OPEN SYSTEMS<sup>d</sup>" "Liquid" column from "3<sup>1</sup>" to "(3)<sup>1</sup>". (*Fire Prevention and Building Safety Commission; 675 IAC 13-2.4-14*)

**675 IAC 13-2.4-15** Section 308.2; Group I-2

Authority: IC 22-13-2-2; IC 22-13-2-13

Affected: IC 22-12; IC 22-13; IC 22-14; IC 22-15; IC 36-7

**Sec. 15.** Change the fourth sentence of Section 308.2 Group I-2 to read as follows: A facility such as the above with five (5) or fewer persons shall be classified as a Group R-3 or shall comply with the Indiana Residential Code (675 IAC 14) as a Class 1 structure. (*Fire Prevention and Building Safety Commission; 675 IAC 13-2.4-15*)

**675 IAC 13-2.4-16** Section 308.3; Group I-2

Authority: IC 22-13-2-2; IC 22-13-2-13

Affected: IC 22-12; IC 22-13; IC 22-14; IC 22-15; IC 36-7

**Sec. 16.** Change the last sentence of Section 308.3 Group I-2 to read as follows: A facility such as the above shall be classified as a Group R-3 or shall comply with the Indiana Residential Code (675 IAC 14) as a Class 1 structure. (*Fire Prevention and Building Safety Commission; 675 IAC 13-2.4-16*)

**675 IAC 13-2.4-17** Section 308.5.1; adult care facility

Authority: IC 22-13-2-2; IC 22-13-2-13

Affected: IC 22-12; IC 22-13; IC 22-14; IC 22-15; IC 36-7

**Sec. 17.** Add an Exception to Section 308.5.1 Adult care facility to read as follows: Exception: Where the occupants are capable of responding to an emergency situation without physical assistance from the staff, the facility may be classified as a Group A-3. (*Fire Prevention and Building Safety Commission; 675 IAC 13-2.4-17*)

**675 IAC 13-2.4-18** Section 309.1; mercantile Group M

Authority: IC 22-13-2-2; IC 22-13-2-13

Affected: IC 22-12; IC 22-13; IC 22-14; IC 22-15; IC 36-7

**Sec. 18.** Change in Section 309.1 "motor vehicle service

stations” to read “motor fuel dispensing facilities”. (*Fire Prevention and Building Safety Commission; 675 IAC 13-2.4-18*)

**675 IAC 13-2.4-19 Section 310.1; residential Group “R”**

Authority: IC 22-13-2-2; IC 22-13-2-13  
Affected: IC 22-12; IC 22-13; IC 22-14; IC 22-15; IC 36-7

**Sec. 19. Change Section 310.1 Residential Group “R” as follows:**

(1) Add to the end of the Group R-3 description a sentence to read as follows: One and two family dwellings and townhouses not more than three (3) stories in height are regulated by the Indiana Residential Code (675 IAC 14) (See Section 101.2).

(2) Change the last paragraph of the R-4 description to read as follows: Group R-4 occupancies shall meet the requirements for construction as defined for Group R-3 except for the height and area limitations provided in Section 503, or shall comply with the Indiana Residential Code (675 IAC 14) as a Class 1 structure.

(3) Add to the end of the first paragraph after “24 hours” the words “or bed and breakfast establishment”.

(*Fire Prevention and Building Safety Commission; 675 IAC 13-2.4-19*)

**675 IAC 13-2.4-20 Section 310.2; bed and breakfast establishment**

Authority: IC 22-13-2-2; IC 22-13-2-13  
Affected: IC 22-12; IC 22-13; IC 22-14; IC 22-15; IC 36-7

**Sec. 20. Add the definition of BED AND BREAKFAST ESTABLISHMENT to Section 310.2 Definitions before BOARDING HOUSE to read as follows: BED AND BREAKFAST ESTABLISHMENT. An operator occupied residence that:**

1. provides sleeping accommodations to the public for a fee;
2. Has no more than fourteen (14) quest rooms;
3. Provides breakfast to its guests as part of the fee; and
4. Provides sleeping accommodations for no more than thirty (30) consecutive days to a particular guest.

The term does not include hotels, motels, boarding houses, or food service establishments. The operator may reside within the establishment or on contiguous property. (*Fire Prevention and Building Safety Commission; 675 IAC 13-2.4-20*)

**675 IAC 13-2.4-21 Section 311.2; moderate-hazard storage**

Authority: IC 22-13-2-2; IC 22-13-2-13  
Affected: IC 22-12; IC 22-13; IC 22-14; IC 22-15; IC 36-7

**Sec. 21. Change in Section 311.2 Moderate-hazard storage, Group S-1 “Aircraft Hanger” to read “Aircraft Repair Hanger”. (*Fire Prevention and Building Safety Commission; 675 IAC 13-2.4-21*)**

**675 IAC 13-2.4-22 Section 311.3; low-hazard storage**

Authority: IC 22-13-2-2; IC 22-13-2-13  
Affected: IC 22-12; IC 22-13; IC 22-14; IC 22-15; IC 36-7

**Sec. 22. Add to the beginning of the list of occupancies before “Asbestos” in Section 311.3 Low-hazard storage, Group S-2 “Aircraft Hanger”. (*Fire Prevention and Building Safety Commission; 675 IAC 13-2.4-22*)**

**675 IAC 13-2.4-23 Section 312.1; general**

Authority: IC 22-13-2-2; IC 22-13-2-13  
Affected: IC 22-12; IC 22-13; IC 22-14; IC 22-15; IC 36-7

**Sec. 23. Change Section 312.1 General to read as follows: Group U Occupancies shall include buildings or structures, or portions thereof, and shall be classified as follows:**

**Division 1. Private garages, carports, sheds and agricultural buildings that are Class 1 structures.**

**Division 2. Tanks and towers that are Class 1 structures. Agricultural buildings that are not Class 1 structures may be regulated by local ordinance. (*Fire Prevention and Building Safety Commission; 675 IAC 13-2.4-23*)**

**675 IAC 13-2.4-24 Section 402.3; lease plan**

Authority: IC 22-13-2-2; IC 22-13-2-13  
Affected: IC 22-12; IC 22-13; IC 22-14; IC 22-15; IC 36-7

**Sec. 24. Delete Section 402.3 Lease Plan. (*Fire Prevention and Building Safety Commission; 675 IAC 13-2.4-24*)**

**675 IAC 13-2.4-25 Section 404.2; use**

Authority: IC 22-13-2-2; IC 22-13-2-13  
Affected: IC 22-12; IC 22-13; IC 22-14; IC 22-15; IC 36-7

**Sec. 25. Delete Section 404.2 Use and substitute as follows: See the Indiana Fire Code (675 IAC 22). (*Fire Prevention and Building Safety Commission; 675 IAC 13-2.4-25*)**

**675 IAC 13-2.4-26 Section 405.1; general**

Authority: IC 22-13-2-2; IC 22-13-2-13  
Affected: IC 22-12; IC 22-13; IC 22-14; IC 22-15; IC 36-7

**Sec. 26. Delete Exception 1 of Section 405.1 General and substitute as follows: See Section 101.2. (*Fire Prevention and Building Safety Commission; 675 IAC 13-2.4-26*)**

**675 IAC 13-2.4-27 Section 406.2.2; clear height**

Authority: IC 22-13-2-2; IC 22-13-2-13  
Affected: IC 22-12; IC 22-13; IC 22-14; IC 22-15; IC 36-7

**Sec. 27. Change Section 406.2.2 Clear height to read as follows: Where a parking tier provides parking spaces for individuals with disabilities or vehicular access to parking spaces for individuals with disabilities the minimum clear height shall not be less than seven foot, six inches (7' 6"). Exception: A lesser clear height may be permitted where the building official approves a mechanical-access parking garage. (*Fire Prevention and Building Safety Commission; 675 IAC 13-2.4-27*)**

**675 IAC 13-2.4-28 Section 406.5; motor vehicle service station**

Authority: IC 22-13-2-2; IC 22-13-2-13  
Affected: IC 22-12; IC 22-13; IC 22-14; IC 22-15; IC 36-7

## Proposed Rules

**Sec. 28. Change Section 406.5 to read motor fuel dispensing facilities.** (*Fire Prevention and Building Safety Commission; 675 IAC 13-2.4-28*)

**675 IAC 13-2.4-29 Section 406.5.1; construction**  
Authority: IC 22-13-2-2; IC 22-13-2-13  
Affected: IC 22-12; IC 22-13; IC 22-14; IC 22-15; IC 36-7

**Sec. 29. Change in Section 406.5.1 “motor vehicle stations” to read “motor fuel dispensing facilities”.** (*Fire Prevention and Building Safety Commission; 675 IAC 13-2.4-29*)

**675 IAC 13-2.4-30 Section 406.6.1; general**  
Authority: IC 22-13-2-2; IC 22-13-2-13  
Affected: IC 22-12; IC 22-13; IC 22-14; IC 22-15; IC 36-7

**Sec. 30. Change in Section 406.6.1 “motor vehicle service stations” to read “motor fuel dispensing facilities.** (*Fire Prevention and Building Safety Commission; 675 IAC 13-2.4-30*)

**675 IAC 13-2.4-31 Section 412.1.6; accessibility**  
Authority: IC 22-13-2-2; IC 22-13-2-13  
Affected: IC 22-12; IC 22-13; IC 22-14; IC 22-15; IC 36-7

**Sec. 31. Delete Section 412.1.6 Accessibility.** (*Fire Prevention and Building Safety Commission; 675 IAC 13-2.4-31*)

**675 IAC 13-2.4-32 Section 412.2.3; floor drains**  
Authority: IC 22-13-2-2; IC 22-13-2-13  
Affected: IC 22-12; IC 22-13; IC 22-14; IC 22-15; IC 36-7

**Sec. 32. Change the last sentence to Section 412.2.3 to read as follows: Floor drains shall discharge through an oil separator to an approved point of discharge.** (*Fire Prevention and Building Safety Commission; 675 IAC 13-2.4-32*)

**675 IAC 13-2.4-33 Section 412.3; residential aircraft hangers**  
Authority: IC 22-13-2-2; IC 22-13-2-13  
Affected: IC 22-12; IC 22-13; IC 22-14; IC 22-15; IC 36-7

**Sec. 33. Delete Section 412.3 Residential aircraft hangers.** (*Fire Prevention and Building Safety Commission; 675 IAC 13-2.4-33*)

**675 IAC 13-2.4-34 Section 414.1.3; information required**  
Authority: IC 22-13-2-2; IC 22-13-2-13  
Affected: IC 22-12; IC 22-13; IC 22-14; IC 22-15; IC 36-7

**Sec. 34. Delete Section 414.1.3 Information required and substitute as follows: See the General Administrative Rules (675 IAC 12-6), the Indiana Fire Code (675 IAC 22), and the rules for Industrialized Building Systems (675 IAC 15).** (*Fire Prevention and Building Safety Commission; 675 IAC 13-2.4-34*)

**675 IAC 13-2.4-35 Section 414.2.4; hazardous material in Group M display and storage areas and in Group S storage areas**

Authority: IC 22-13-2-2; IC 22-13-2-13  
Affected: IC 22-12; IC 22-13; IC 22-14; IC 22-15; IC 36-7

**Sec. 35. Change in Section 414.2.4 Hazardous material in Group M display and storage areas and in Group S storage areas, “307.2(1)” to “307.7.(1) and “307.2(2)” to “307.7(2)”.** (*Fire Prevention and Building Safety Commission; 675 IAC 13-2.4-35*)

**675 IAC 13-2.4-36 Table 414.2.4; maximum allowable quantity per indoor and outdoor control area in Groups M and S occupancies nonflammable solids, nonflammable and noncombustible liquids<sup>d, e, f</sup>**

Authority: IC 22-13-2-2; IC 22-13-2-13  
Affected: IC 22-12; IC 22-13; IC 22-14; IC 22-15; IC 36-7

**Sec. 36. (a) In TABLE 414.2.4 in the column Maximum allowable quantity per control area solids (pounds), delete the parenthetical marks around pounds as follows: (pounds).**

**(b) In TABLE 414.2.4 in the column Maximum allowable quantity per control area Liquid gallons (pounds), delete the word “(pounds)”.** (*Fire Prevention and Building Safety Commission; 675 IAC 13-2.4-36*)

**675 IAC 13-2.4-37 Section 415.2; definitions**  
Authority: IC 22-13-2-2; IC 22-13-2-13  
Affected: IC 22-12; IC 22-13; IC 22-14; IC 22-15; IC 36-7

**Sec. 37. Delete in Section 415.2 Definitions the second and third sentences in the definition of IMMEDIATELY DANGEROUS TO LIFE AND HEALTH (IDLH).** (*Fire Prevention and Building Safety Commission; 675 IAC 13-2.4-37*)

**675 IAC 13-2.4-38 Table 415.9.2.1.1; quantity limits for hazardous materials in a single fabrication area in Group H-5**

Authority: IC 22-13-2-2; IC 22-13-2-13  
Affected: IC 22-12; IC 22-13; IC 22-14; IC 22-15; IC 36-7

**Sec. 38. Change in footnote d, Table 415.9.2.1.1 “Tables 307.7(1) and 415.3.2” to read “Table 415.3.2”.** (*Fire Prevention and Building Safety Commission; 675 IAC 13-2.4-38*)

**675 IAC 13-2.4-39 Section 415.9.6 and Section 415.9.7; piping and tubing and continuous gas detection systems**

Authority: IC 22-13-2-2; IC 22-13-2-13  
Affected: IC 22-12; IC 22-13; IC 22-14; IC 22-15; IC 36-7

**Sec. 39. Delete Section 415.9.6 Piping and tubing and Section 415.9.7 Continuous gas detection systems.** (*Fire Prevention and Building Safety Commission; 675 IAC 13-2.4-39*)

**675 IAC 13-2.4-40 Section 417.1; general**  
 Authority: IC 22-13-2-2; IC 22-13-2-13  
 Affected: IC 22-12; IC 22-13; IC 22-14; IC 22-15; IC 36-7

**Sec. 40. Change Section 417.1 General to read as follows: A drying room or dry kiln installed within a building shall be constructed entirely of approved noncombustible materials.** (*Fire Prevention and Building Safety Commission; 675 IAC 13-2.4-40*)

**675 IAC 13-2.4-41 Section 506.2.2; open space limits**  
 Authority: IC 22-13-2-2; IC 22-13-2-13  
 Affected: IC 22-12; IC 22-13; IC 22-14; IC 22-15; IC 36-7

**Sec. 41. Add an Exception to Section 506.2.2 Open space limits to read as follows: Exception: A 4-hour fire wall shall be considered equivalent to sixty (60) feet of open space for any building.** (*Fire Prevention and Building Safety Commission; 675 IAC 13-2.4-41*)

**675 IAC 13-2.4-42 Section 507.2; sprinklered**  
 Authority: IC 22-13-2-2; IC 22-13-2-13  
 Affected: IC 22-12; IC 22-13; IC 22-14; IC 22-15; IC 36-7

**Sec. 42. Change Section 507.2 Sprinklered, one-story as follows:**

**(1) Change the first paragraph to read as follows: The area of a one-story, Group A-4, B, E, F, M or S building, other than Type V construction, shall not be limited when the building is provided with an automatic sprinkler system throughout in accordance with Section 903.3.1.1, and is surrounded and adjoined by public ways or yards not less than sixty (60) feet (18,288 mm) in width.**

**(2) Change in Exception 1 “NFPA 231C” to “NFPA 13 (675 IAC 13-1)”.**

(*Fire Prevention and Building Safety Commission; 675 IAC 13-2.4-42*)

**675 IAC 13-2.4-43 Section 507.3; two story**  
 Authority: IC 22-13-2-2; IC 22-13-2-13  
 Affected: IC 22-12; IC 22-13; IC 22-14; IC 22-15; IC 36-7

**Sec. 43. Change Section 507.3 Two-story to read as follows: The area of a two-story, Group B, E, F, M, or S building, other than Type V construction, shall not be limited when the building is provided with an automatic sprinkler system in accordance with Section 903.3.1.1 throughout, and is surrounded and adjoined by public ways or yards not less than sixty (60) feet (18,288 mm) in width.** (*Fire Prevention and Building Safety Commission; 675 IAC 13-2.4-43*)

**675 IAC 13-2.4-44 Section 507.9; Group A-3 buildings**  
 Authority: IC 22-13-2-2; IC 22-13-2-13  
 Affected: IC 22-12; IC 22-13; IC 22-14; IC 22-15; IC 36-7

**Sec. 44. Add Section 507.9 to the end of Section 507 to read as follows: 507.9 Group A-3 buildings. The area of a one-story, Group A-3 building used as a church, community hall, exhibition hall, gymnasium, lecture hall, indoor swimming pool or tennis court of Type I or II construction shall not be limited when all of the following conditions are met:**

- 1. The building shall not have stage other than a platform.**
- 2. The building shall be equipped throughout with an automatic sprinkler system in accordance with Section 903.3.1.1.**
- 3. The assembly floor shall be located at, or within twenty-one (21) inches of street or grade level and all exits are provided with ramps complying with Section 1003.3.4 to the street or grade level.**
- 4. The building shall be surrounded and adjoined by public ways or yards not less than sixty (60) feet in width.**

(*Fire Prevention and Building Safety Commission; 675 IAC 13-2.4-44*)

**675 IAC 13-2.4-45 Section 704.9; vertical separation of openings**  
 Authority: IC 22-13-2-2; IC 22-13-2-13  
 Affected: IC 22-12; IC 22-13; IC 22-14; IC 22-15; IC 36-7

**Sec. 45. Change Exception 2 of Section 704.9 Vertical separation of openings to read as follows: This section shall not apply to buildings equipped throughout with an automatic sprinkler system in accordance with Section 903.3.1.1 or Section 903.3.1.2.** (*Fire Prevention and Building Safety Commission; 675 IAC 13-2.4-45*)

**675 IAC 13-2.4-46 Section 715.5.3.1; penetrations of shaft enclosures**  
 Authority: IC 22-13-2-2; IC 22-13-2-13  
 Affected: IC 22-12; IC 22-13; IC 22-14; IC 22-15; IC 36-7

**Sec. 46. Change Section 715.5.3.1 Penetrations of shaft enclosures by deleting in the fourth line of the first paragraph the words “and smoke”.** (*Fire Prevention and Building Safety Commission; 675 IAC 13-2.4-46*)

**675 IAC 13-2.4-47 Section 716.2.4; stairways**  
 Authority: IC 22-13-2-2; IC 22-13-2-13  
 Affected: IC 22-12; IC 22-13; IC 22-14; IC 22-15; IC 36-7

**Sec. 47. Change Section 716.2.4 Stairways to read as follows: Fireblocking shall be provided in concealed spaces between stair stringers at the top and bottom of the run and between studs along and in line with the run of stairs, if the walls under the stairs are unfinished, and shall comply with requirements of Section 1005.3.2.2.** (*Fire Prevention and Building Safety Commission; 675 IAC 13-2.4-47*)

**675 IAC 13-2.4-48 Table 719.1(2); rated fire-resistive periods for various walls and partitions**  
 Authority: IC 22-13-2-2; IC 22-13-2-13  
 Affected: IC 22-12; IC 22-13; IC 22-14; IC 22-15; IC 36-7

## Proposed Rules

Sec. 48. Change TABLE 719.1(2) RATED FIRE-RESISTIVE PERIODS FOR VARIOUS WALLS AND PARTITIONS as follows:

TABLE 719.1(2)  
RATED FIRE RESISTANCE PERIODS FOR VARIOUS WALLS AND PARTITIONS<sup>a, b, p</sup>

MATERIAL	ITEM NUMBER	CONSTRUCTION	MINIMUM FINISHED THICKNESS FACE-TO-FACE (inches)			
			4 HR.	3 Hr.	2 Hr.	1 Hr.
	15-1.6 <sup>l,m</sup>	2" by 6" fire-retardant-treated wood studs 16" on center, interior face has two layers of 5/8" Type X gypsum with the base layer placed vertically and attached with 6d box nails 12" on center. The face layer is placed horizontally and attached with 8d box nails 8" on center at joints and 12" on center elsewhere. The exterior face has a base layer of 5/8" Type X gypsum sheathing placed vertically with 6d box nails 8" on center at joints and 12" on center elsewhere. An approved building paper is next applied, followed by self-furred exterior lath attached with 2 1/2", No. 12 gage galvanized roofing nails with a 5/8" diameter head and spaced 6" on center along each stud. Cement plaster consisting of a 1/2" brown coat is then applied. The scratch coat is mixed in the proportion of 1:3 by weight, cement to sand with 10 pounds of hydrated lime and 3 pounds of approved additives or admixtures per sack of cement. The brown coat is mixed in the proportion of 1:4 by weight, cement to sand with the same amounts of hydrated lime and approved additives or admixtures used in the scratch coat.	---	---	8 1/4	---
15. Exterior or interior walls	15-1.7 <sup>l,m</sup>	2" by 6" wood studs 16" on center. The exterior face has a layer of 5/8" Type X gypsum sheathing placed vertically with 6d box nails 8" on center at joints and 12" No. 18 gage self-furred exterior lath attached with 8d by 2 1/2" long galvanized roofing nails spaced 6" on center along each stud. Cement plaster consisting of a 1/2" scratch coat, a bonding agent and a 1/2" brown coat and finish coat is then applied. The scratch coat is mixed in the proportion of 1:3 by weight, cement to sand with 10 pounds of hydrated lime and 3 pounds of approved additives or admixtures per sack of cement. The brown coat is mixed in the proportion of 1:4 by weight, cement to sand with the same amounts of hydrated lime and approved additives or admixtures used in the scratch coat. The interior is covered with 5/8" gypsum lath with 1" hexagonal mesh of 0.035 inch (No. 20 B.W. gage) woven wire lath furred out 5/16" and 1" perlite or vermiculite gypsum plaster. Lath nailed with 1 1/8" by No. 13 gage by 19/64" head plasterboard blue nails spaced 5" on center. Mesh attached by 1 3/4" by No. 12 gage by 5/8" head nails with 5/8" furrings, spaced 8" on center. The plaster mix shall not exceed 100 pounds of gypsum to 2 1/2" cubic feet of aggregate.	---	---	8 3/8	---
	15-1.8 <sup>l,m</sup>	2" by 6" wood studs 15" on center. The exterior face has a layer of 5/8" Type X gypsum sheathing placed vertically with 6d box nails 8" on center at joints and 12" on center elsewhere. An approved building paper is next applied, followed by 1 1/2" by No. 17 gage self-furred exterior lath attached with 8d by 2 1/2" long galvanized roofing nails spaced 6" on center along each stud. Cement plaster consisting of a 1/2" scratch coat, and 1/2" brown coat is then applied. The plaster may be placed by machine. The scratch coat is mixed in the proportion of 1:4 by weight, plastic cement to sand. The brown coat is mixed in the proportion of 1:5 by weight, plastic cement to sand. The interior is covered with 5/8" gypsum lath with 1" hexagonal mesh of No. 20 gage woven wire lath furred out 5/16" and 1" perlite or vermiculite gypsum plaster. Lath nailed with 1 1/8" by No. 13 gage by 19/64" and head plasterboard blue nails spaced 5" on center. Mesh attached by 1 3/4" by No. 12 gage by 5/8" head nails with 5/8" furrings, spaced 8" on center. The plaster mix shall not exceed 100 pounds of gypsum to 2 1/2" cubic feet of aggregate.	---	---	8 3/8	---

15-1.12 <sup>a</sup>	2" by 6" wood studs at 16" centers with double top plates, single bottom plate; interior and exterior sides covered with 5/8" Type X gypsum wallboard, 4 feet wide, applied horizontally or vertically with vertical joints over studs, and fastened with 2 1/4" Type S drywall screws, spaced 12" on center. Cavity filled with 4 1/2" mineral wool insulation.	---	---	---	6 3/4
15-1.13 <sup>a</sup>	2" by 5" wood studs at 16" centers with double top plates, single bottom plate; interior and exterior sides covered with 5/8" Type X gypsum wallboard, 4 feet wide, applied horizontally or vertically with vertical joints over studs, and fastened with 2 1/4" Type S drywall screws, spaced 7" on center.	---	---	---	6 3/4
15-1.14 <sup>a</sup>	2" by 4" wood studs at 16" centers with double top plates, single bottom plate; interior and exterior sides covered with 5/8" Type X gypsum wallboard and sheathing, respectively, 4 feet wide, applied horizontally or vertically with vertical joints over studs, and fastened with 2 1/4" Type S drywall screws, spaced 12" on center. Cavity to be filled with 3 1/2" mineral wool insulation.	---	---	---	4 3/4

<sup>a</sup>The design stress of studs shall be equal to a maximum of 100 percent of the allowable  $F_c$  calculated in accordance with Section 2306. (Portions of Table and footnotes not shown do not change) (*Fire Prevention and Building Safety Commission; 675 IAC 13-2.4-48*)

**675 IAC 13-2.4-49 Section 720.3.4; concrete masonry lintels**

Authority: IC 22-13-2-2; IC 22-13-2-13  
Affected: IC 22-12; IC 22-13; IC 22-14; IC 22-15; IC 36-7

**Sec. 49. Change in Section 720.3.4 Concrete masonry lintels "by approved alternate methods" to read "as approved by the building official".** (*Fire Prevention and Building Safety Commission; 675 IAC 13-2.4-49*)

**675 IAC 13-2.4-50 Section 720.3.5; concrete masonry columns**

Authority: IC 22-13-2-2; IC 22-13-2-13  
Affected: IC 22-12; IC 22-13; IC 22-14; IC 22-15; IC 36-7

**Sec. 50. Change in Section 720.3.5 Concrete masonry columns "by approved alternate methods" to read "as approved by the building official".** (*Fire Prevention and Building Safety Commission; 675 IAC 13-2.4-50*)

**675 IAC 13-2.4-51 Section 801.1.3; applicability**

Authority: IC 22-13-2-2; IC 22-13-2-13  
Affected: IC 22-12; IC 22-13; IC 22-14; IC 22-15; IC 36-7

**Sec. 51. Delete Section 801.1.3 Applicability., and substitute "See local ordinance".** (*Fire Prevention and Building Safety Commission; 675 IAC 13-2.4-51*)

**675 IAC 13-2.4-52 Section 805; decorations and trim**

Authority: IC 22-13-2-2; IC 22-13-2-13  
Affected: IC 22-12; IC 22-13; IC 22-14; IC 22-15; IC 36-7

**Sec. 52. Delete Section 805 Decorations and trim., and substitute "See the Indiana Fire Code (675 IAC 22)".** (*Fire Prevention and Building Safety Commission; 675 IAC 13-2.4-52*)

**675 IAC 13-2.4-53 Section 901.3; modifications**

Authority: IC 22-13-2-2; IC 22-13-2-13  
Affected: IC 22-12; IC 22-13; IC 22-14; IC 22-15; IC 36-7

**Sec. 53. Change Section 901.3 Modifications to read as follows: No person shall remove or modify any fire protection system installed or maintained in accordance with the rules of the commission without notifying the servicing fire department prior to receiving approval from the building official.** (*Fire Prevention and Building Safety Commission; 675 IAC 13-2.4-53*)

**675 IAC 13-2.4-54 Section 901.5; acceptance tests**

Authority: IC 22-13-2-2; IC 22-13-2-13  
Affected: IC 22-12; IC 22-13; IC 22-14; IC 22-15; IC 36-7

**Sec. 54. Delete Section 901.5 Acceptance tests and substitute to read as follows: 901.5 Acceptance tests. Fire protection systems shall be tested in accordance with the rules of the commission at the expense of the owner or owner's representative. When requested by the building official, such tests shall be conducted in their presence. Prior to conducting such tests, the local building official shall be given at least 48-hour notice. It shall be unlawful to occupy portions of a structure until the required fire protection systems within that portion of the structure have been completed, successfully tested and fully operational with appropriate contractor's material and test certificates filed out in full and provided to the building official.** (*Fire Prevention and Building Safety Commission; 675 IAC 13-2.4-54*)

**675 IAC 13-2.4-55 Section 901.6.1; automatic sprinkler systems**

Authority: IC 22-13-2-2; IC 22-13-2-13  
Affected: IC 22-12; IC 22-13; IC 22-14; IC 22-15; IC 36-7

**Sec. 55. Delete Exception 1 to Section 901.6.1 Automatic sprinkler systems and substitute "See Section 101.2".** (*Fire Prevention and Building Safety Commission; 675 IAC 13-2.4-55*)

**675 IAC 13-2.4-56 Section 902; definitions**

Authority: IC 22-13-2-2; IC 22-13-2-13  
Affected: IC 22-12; IC 22-13; IC 22-14; IC 22-15; IC 36-7

**Sec. 56. Change Section 902 Definitions as follows:**

## Proposed Rules

(1) Add the definition of Labeled after Listed to read as follows: **LABELED.** Equipment or materials to which has been attached a label, symbol, or other identifying mark of an organization engaged in product evaluation, that maintains periodic inspection of production of labeled equipment or materials and by whose labeling the manufacturer indicates compliance with appropriate standards or performance in a specified manner.

(2) Delete the definition of **RECORD DRAWINGS.**

*(Fire Prevention and Building Safety Commission; 675 IAC 13-2.4-56)*

### 675 IAC 13-2.4-57 Section 903.2.5; Group I

Authority: IC 22-13-2-2; IC 22-13-2-13

Affected: IC 22-12; IC 22-13; IC 22-14; IC 22-15; IC 36-7

Sec. 57. Change Section 903.2.5 Group A-3 as follows:

(1) Change "Exception" to read "Exception 1:".

(2) Add Exception 2 to read as follows: **Exception 2:** In jails, prisons and reformatories, the piping system may be dry, provided a manually operated valve is installed at a continuously monitored location. Opening the valve will cause the system to be charged. The valve may be located in a locked cabinet or enclosure provided the activation of a sprinkler unlocks the cabinet or enclosure.

*(Fire Prevention and Building Safety Commission; 675 IAC 13-2.4-57)*

### 675 IAC 13-2.4-58 Section 903.3.1.1.1; exempt locations

Authority: IC 22-13-2-2; IC 22-13-2-13

Affected: IC 22-12; IC 22-13; IC 22-14; IC 22-15; IC 36-7

Sec. 58. Change Section 903.3.1.1.1 Exempt Locations as follows: Delete the text of item 5 and substitute the following: Elevator equipment rooms and hoistways used exclusively for the operation of elevators and which are separated from the remainder of the building by two (2) hour fire-resistive construction. Penetrations between machine rooms and hoistways necessary for the safe operation of an elevator and vents required by Section 3004 of this code need not be fire-rated. *(Fire Prevention and Building Safety Commission; 675 IAC 13-2.4-58)*

### 675 IAC 13-2.4-59 Section 903.3.1.3; NFPA 13D sprinkler systems

Authority: IC 22-13-2-2; IC 22-13-2-13

Affected: IC 22-12; IC 22-13; IC 22-14; IC 22-15; IC 36-7

Sec. 59. Delete Section 903.3.1.3 NFPA 13D Sprinkler Systems and substitute to read as follows: See Section 101.2. *(Fire Prevention and Building Safety Commission; 675 IAC 13-2.4-59)*

### 675 IAC 13-2.4-60 Section 903.3.5.1.1; limited area sprinkler systems

Authority: IC 22-13-2-2; IC 22-13-2-13

Affected: IC 22-12; IC 22-13; IC 22-14; IC 22-15; IC 36-7

Sec. 60. Change in the Exception for Section 903.3.5.1.1 Limited area sprinkler systems "an approved" to "a listed".

*(Fire Prevention and Building Safety Commission; 675 IAC 13-2.4-60)*

### 675 IAC 13-2.4-61 Section 903.3.6; hose threads

Authority: IC 22-13-2-2; IC 22-13-2-13

Affected: IC 22-12; IC 22-13; IC 22-14; IC 22-15; IC 36-7

Sec. 61. Change Section 903.3.6 Hose threads to read as follows: Fire hose threads used in connection with automatic sprinkler systems shall be compatible with the equipment used by the servicing fire department. *(Fire Prevention and Building Safety Commission; 675 IAC 13-2.4-61)*

### 675 IAC 13-2.4-62 Section 903.3.7; fire department connections

Authority: IC 22-13-2-2; IC 22-13-2-13

Affected: IC 22-12; IC 22-13; IC 22-14; IC 22-15; IC 36-7

Sec. 62. Change Section 903.3.7 Fire department connections to read as follows: The servicing fire department shall be consulted before placing the fire department hose connections at specific locations when there is no local ordinance specifying locations or the connections shall be placed as required by local ordinance. *(Fire Prevention and Building Safety Commission; 675 IAC 13-2.4-62)*

### 675 IAC 13-2.4-63 Section 903.4; sprinkler system monitoring and alarms

Authority: IC 22-13-2-2; IC 22-13-2-13

Affected: IC 22-12; IC 22-13; IC 22-14; IC 22-15; IC 36-7

Sec. 63. Delete Exception 1 to Section 903.4 Sprinkler systems monitoring and alarms and substitute: See Section 101.2. *(Fire Prevention and Building Safety Commission; 675 IAC 13-2.4-63)*

### 675 IAC 13-2.4-64 Section 903.4.2; alarms

Authority: IC 22-13-2-2; IC 22-13-2-13

Affected: IC 22-12; IC 22-13; IC 22-14; IC 22-15; IC 36-7

Sec. 64. Change Section 903.4.2 Alarms to read as follows: Listed audible and visible devices shall be connected to every automatic sprinkler system. Such sprinkler water-flow alarm devices shall be activated by water flow equivalent to the flow of a single sprinkler of the smallest orifice size installed in the system. Alarm devices shall be provided on the exterior of the building facing the public street, road or highway that is in accordance with its legal address. Where buildings are not directly facing the public street, road or highway or are in excess of 250 feet from the public street, road or highway, the servicing fire department shall be consulted in determining a location prior to the installation of the exterior audible and visible device. Where a fire alarm system is installed, actuation of the automatic sprinkler system shall actuate the building fire alarm system.

Exception: Sprinkler systems which are monitored by an approved supervisory station are not required to have the



listed audible and visible device located on the exterior wall facing the public street, road or highway.

*(Fire Prevention and Building Safety Commission; 675 IAC 13-2.4-64)*

**675 IAC 13-2.4-65 Section 903.4.3; floor control valves**

Authority: IC 22-13-2-2; IC 22-13-2-13

Affected: IC 22-12; IC 22-13; IC 22-14; IC 22-15; IC 36-7

**Sec. 65. Change Section 903.4.3 Floor control valves as follows:**

**(1) Change “approved” to “a listed”.**

**(2) Change “high-rise buildings” to “buildings 4 stories or more in height”.**

*(Fire Prevention and Building Safety Commission; 675 IAC 13-2.4-65)*

**675 IAC 13-2.4-66 Section 904.1; general**

Authority: IC 22-13-2-2; IC 22-13-2-13

Affected: IC 22-12; IC 22-13; IC 22-14; IC 22-15; IC 36-7

**Sec. 66. Change Section 904.1 General to read as follows: Automatic fire-extinguishing systems, other than automatic sprinkler systems, shall be designed, installed, and tested in accordance with the provisions of this section and the applicable reference standards, as stated in this code.** *(Fire Prevention and Building Safety Commission; 675 IAC 13-2.4-66)*

**675 IAC 13-2.4-67 Section 904.2.1; hood suppression systems**

Authority: IC 22-13-2-2; IC 22-13-2-13

Affected: IC 22-12; IC 22-13; IC 22-14; IC 22-15; IC 36-7

**Sec. 67. Delete in the third line of Section 904.2.1 Hood suppression systems the words “the International Fire Code or”.** *(Fire Prevention and Building Safety Commission; 675 IAC 13-2.4-67)*

**675 IAC 13-2.4-68 Section 904.11; commercial cooking systems**

Authority: IC 22-13-2-2; IC 22-13-2-13

Affected: IC 22-12; IC 22-13; IC 22-14; IC 22-15; IC 36-7

**Sec. 68. Delete the last sentence of Section 904.11 Commercial cooking systems and substitute as follows: Automatic fire-extinguishing systems shall be installed in accordance with the Indiana Mechanical Code (675 IAC 18).** *(Fire Prevention and Building Safety Commission; 675 IAC 13-2.4-68)*

**675 IAC 13-2.4-69 Section 904.11.1, Section 904.11.2, Section 904.11.3, 904.11.4, and 904.11.4.1; manual system operation, system interconnection, carbon dioxide systems, ventilation systems, special provisions for automatic sprinkler systems, and listed sprinklers**

Authority: IC 22-13-2-2; IC 22-13-2-13

Affected: IC 22-12; IC 22-13; IC 22-14; IC 22-15; IC 36-7

**Sec. 69. Delete Sections 904.11.1, 904.11.2, 904.11.3, 904.11.3.1, 904.11.4 and 904.11.4.1 Manual system operation, System interconnection, Carbon dioxide systems, ventilation systems, Special provisions for automatic sprinkler systems, Listed sprinklers and substitute: “See the Indiana Mechanical Code (675 IAC 18).** *(Fire Prevention and Building Safety Commission; 675 IAC 13-2.4-69)*

**675 IAC 13-2.4-70 Section 905.2.2.1; fire department connections**

Authority: IC 22-13-2-2; IC 22-13-2-13

Affected: IC 22-12; IC 22-13; IC 22-14; IC 22-15; IC 36-7

**Sec. 70. Add Section 905.2.1 after 905.2 to read as follows: 905.2.1 Fire Department connections. The location of fire department connections shall be in accordance with Section 903.3.7.** *(Fire Prevention and Building Safety Commission; 675 IAC 13-2.4-70)*

**675 IAC 13-2.4-71 Section 905.3.5.1; hose and cabinet**

Authority: IC 22-13-2-2; IC 22-13-2-13

Affected: IC 22-12; IC 22-13; IC 22-14; IC 22-15; IC 36-7

**Sec. 71. Delete Section 905.3.5.1 Hose and cabinet and substitute to read as follows: Proper cap and chain shall be provided for the hose connection valve assembly. Hose connection valve assembly shall comply with the provisions in Section 903.3.6.** *(Fire Prevention and Building Safety Commission; 675 IAC 13-2.4-71)*

**675 IAC 13-2.4-72 Section 905.4; location of Class I standpipe hose connections**

Authority: IC 22-13-2-2; IC 22-13-2-13

Affected: IC 22-12; IC 22-13; IC 22-14; IC 22-15; IC 36-7

**Sec. 72. Change Section 905.4 Location of Class I standpipe hose connections as follows:**

**(1) Delete item 1 and substitute as follows: 1. In every required stairway, a hose connection shall be provided for each floor level above or below grade. Hose connections shall be located at an intermediate floor level landing between floors. Where there are multiple intermediate floor landings between floors, hose connections shall be located at the landing closest to being midway between floors. If intermediate floor level landings are not provided in the required stairway, the hose connection shall be located on the floor-level landing.**

**(2) Delete item 6 and substitute as follows: 6. Where the most remote portion of a non-sprinklered floor or story exceeds one hundred fifty (150) feet (forty-five (45) meters) of travel distance from a required exit or the most remote portion of a sprinklered floor or story exceeds two hundred (200) feet (sixty-one (61) meters) of travel distance from a required exit, additional hose connections shall be provided in approved locations.**

*(Fire Prevention and Building Safety Commission; 675 IAC 13-2.4-72)*

## Proposed Rules

### 675 IAC 13-2.4-73 Section 905.8; dry standpipes

Authority: IC 22-13-2-2; IC 22-13-2-13

Affected: IC 22-12; IC 22-13; IC 22-14; IC 22-15; IC 36-7

Sec. 73. Change Section 905.8 Dry standpipes to read as follows: In buildings requiring standpipes, dry standpipes complying with NFPA 14 are permitted when, the building or structure is unheated and the standpipe is subject to freezing temperatures. (*Fire Prevention and Building Safety Commission; 675 IAC 13-2.4-73*)

### 675 IAC 13-2.4-74 Section 907.1.1; construction documents

Authority: IC 22-13-2-2; IC 22-13-2-13

Affected: IC 22-12; IC 22-13; IC 22-14; IC 22-15; IC 36-7

Sec. 74. Delete Section 907.1.1 Construction documents and substitute to read as follows: See the General Administrative Rules (675 IAC 12-6). (*Fire Prevention and Building Safety Commission; 675 IAC 13-2.4-74*)

### 675 IAC 13-2.4-75 Section 907.2.1.1; systems initiation in Group A occupancies with an occupant load of 1,000 or more

Authority: IC 22-13-2-2; IC 22-13-2-13

Affected: IC 22-12; IC 22-13; IC 22-14; IC 22-15; IC 36-7

Sec. 75. Delete the Exception to Section 907.2.1.1 System initiation in Group A occupancies with an occupant load of 1,000 or more. (*Fire Prevention and Building Safety Commission; 675 IAC 13-2.4-75*)

### 675 IAC 13-2.4-76 Section 907.2.3; Group E

Authority: IC 22-13-2-2; IC 22-13-2-13

Affected: IC 22-12; IC 22-13; IC 22-14; IC 22-15; IC 36-7

Sec. 76. Change Section 907.2.3 Group E as follows:

(1) Delete Exception 2.3 and substitute to read as follows: 2.3 Shops and laboratories involving dust or vapors are protected by heat detectors or other listed detection devices.

(2) Delete in Exception 2.6 the words “, except in locations specifically designated by the building official”.

(*Fire Prevention and Building Safety Commission; 675 IAC 13-2.4-76*)

### 675 IAC 13-2.4-77 Section 907.2.10.1.1.1; R1 hotels and motels

Authority: IC 22-13-2-2; IC 22-13-2-13; IC 22-11-18

Affected: IC 22-12-1-4; IC 22-13; IC 22-14; IC 22-15; IC 36-7

Sec. 77. Add section 907.2.10.1.1.1 after section 907.2.10.1.1 as follows: 907.2.10.1.1.1 R1 Hotels and Motels.

(1) This section only applies to hotels and motels.

(2) All hotels and motels must have functional smoke detectors, and comply with this section and section 907.2.10.1.1

(3) Except as provided in (6), a detector must be installed

in all interior corridors adjacent to sleeping rooms and must be spaced no further apart than thirty (30) feet on center or more than fifteen (15) feet from any wall.

(4) The detectors must be hard wired into a building's electrical system, except as provided in (6).

(5) The detectors must be wired in a manner that activates all the devices in a corridor when one is activated, except as provided in (6).

(6) All single level dwellings, all seasonably occupied dwellings, and all hotels and motels with twelve (12) sleeping rooms or less (and containing no interior corridors) are exempt from the requirements of (3), (4), and (5). In such units:

(A) a detector must be installed in each sleeping room; and

(B) the detector may be battery operated, when allowed by section 907.2.10.2.

If a battery operated detector is installed, it must contain a tamper resistant cover to protect the batteries.

For the purpose of section 907.2.10.1.1.1, the following definitions shall apply:

DWELLING means a residence with at least one (1) dwelling unit as set forth in IC 22-12-1-4(a)(1)(B) and IC 22-12-1-5(a)(1).

HOTELS AND MOTELS means buildings or structures kept, maintained, used, advertised, or held out to the public as inns or places where sleeping accommodations are furnished for hire for transient guest.

SEASONALLY OCCUPIED DWELLINGS means hotels and motels open to the public for occupancy by guests only during any period of time between April 15 and October 15 each year.

SINGLE LEVEL DWELLING means all single level (no more than one (1) level above ground) hotels and motels that have no interior corridors, and whose individual rooms have exterior exits.

(*Fire Prevention and Building Safety Commission; 675 IAC 13-2.4-77*)

### 675 IAC 13-2.4-78 Section 907.2.10.1.2; Groups R-2, R-3R-4 and I-1

Authority: IC 22-13-2-2; IC 22-13-2-13

Affected: IC 22-12; IC 22-13; IC 22-14; IC 22-15; IC 36-7

Sec. 78. In Section 907.2.10.1.2 Groups R-2, R-3, R-4 and I-1, delete the words “and maintained”. (*Fire Prevention and Building Safety Commission; 675 IAC 13-2.4-78*)

### 675 IAC 13-2.4-79 Section 907.2.10.1.4; exceptions

Authority: IC 22-13-2-2; IC 22-13-2-13

Affected: IC 22-12; IC 22-13; IC 22-14; IC 22-15; IC 36-7

Sec. 79. Change the Exception to Section 907.2.10.1.4 to read as follows: Exception: Repairs are exempt from the requirements of this section. (*Fire Prevention and Building Safety Commission; 675 IAC 13-2.4-79*)

**675 IAC 13-2.4-80 Section 907.7; presignal system**

Authority: IC 22-13-2-2; IC 22-13-2-13  
Affected: IC 22-12; IC 22-13; IC 22-14; IC 22-15; IC 36-7

**Sec. 80. Delete Section 907.7 Presignal system.** (*Fire Prevention and Building Safety Commission; 675 IAC 13-2.4-80*)

**675 IAC 13-2.4-81 Section 907.8.1; zoning indicator panel**

Authority: IC 22-13-2-2; IC 22-13-2-13  
Affected: IC 22-12; IC 22-13; IC 22-14; IC 22-15; IC 36-7

**Sec. 81. Change Section 907.8.1 Zoning indicator panel to read as follows: A zoning indicator panel and associated controls shall be provided in a location the servicing fire department will use as their main entrance point in the building. The panel shall be identifiable and accessible at all times. The visual zone indication shall lock in until the system is reset and shall not be canceled by the operation of an audible alarm-silencing switch.** (*Fire Prevention and Building Safety Commission; 675 IAC 13-2.4-81*)

**675 IAC 13-2.4-82 Section 907.14; monitoring**

Authority: IC 22-13-2-2; IC 22-13-2-13  
Affected: IC 22-12; IC 22-13; IC 22-14; IC 22-15; IC 36-7

**Sec. 82. Change Section 907.14 Monitoring to read as follows: Where required by this chapter or by local ordinance, an approved supervising station shall monitor fire alarm systems.** (*Fire Prevention and Building Safety Commission; 675 IAC 13-2.4-82*)

**675 IAC 13-2.4-83 Section 907.15; automatic telephone dialing devices**

Authority: IC 22-13-2-2; IC 22-13-2-13  
Affected: IC 22-12; IC 22-13; IC 22-14; IC 22-15; IC 36-7

**Sec. 83. Change Section 907.15 Automatic telephone-dialing devices to read as follows: Automatic telephone-dialing devices used to transmit an emergency alarm shall not be connected to any fire department telephone number unless approved by the building official.** (*Fire Prevention and Building Safety Commission; 675 IAC 13-2.4-83*)

**675 IAC 13-2.4-84 Sections 907.17 and 907.18; record of completion and instructions**

Authority: IC 22-13-2-2; IC 22-13-2-13  
Affected: IC 22-12; IC 22-13; IC 22-14; IC 22-15; IC 36-7

**Sec. 84. Delete Section 907.17 Record of completion and Section 907.18 Instructions.** (*Fire Prevention and Building Safety Commission; 675 IAC 13-2.4-84*)

**675 IAC 13-2.4-85 Section 909.2; general design requirements**

Authority: IC 22-13-2-2; IC 22-13-2-13  
Affected: IC 22-12; IC 22-13; IC 22-14; IC 22-15; IC 36-7

**Sec. 85. Change Section 909.2 General design require-**

**ments to read as follows: Buildings, structures or parts thereof required by this code to have a smoke control system or systems shall have such systems designed in accordance with the applicable requirements of Section 909 and the generally accepted and well-established principles of engineering relevant to the design. Construction documents shall be as required by the General Administrative Rules (675 IAC 12-6) and the rules for Industrialized Building Systems (675 IAC 15).** (*Fire Prevention and Building Safety Commission; 675 IAC 13-2.4-85*)

**675 IAC 13-2.4-86 Section 909.3; special inspection and test requirements**

Authority: IC 22-13-2-2; IC 22-13-2-13  
Affected: IC 22-12; IC 22-13; IC 22-14; IC 22-15; IC 36-7

**Sec. 86. Delete Section 909.3 Special inspection and test requirements and substitute to read as follows: For special inspections and testing, see the General Administrative Rules (675 IAC 12-6-6(c)(10)(D)).** (*Fire Prevention and Building Safety Commission; 675 IAC 13-2.4-86*)

**675 IAC 13-2.4-87 Section 909.10.2; ducts**

Authority: IC 22-13-2-2; IC 22-13-2-13  
Affected: IC 22-12; IC 22-13; IC 22-14; IC 22-15; IC 36-7

**Sec. 87. Add in the third sentence of Section 909.10.2 Ducts the word “approved” after “with” and before “nationally”.** (*Fire Prevention and Building Safety Commission; 675 IAC 13-2.4-87*)

**675 IAC 13-2.4-88 Section 909.15; control diagrams**

Authority: IC 22-13-2-2; IC 22-13-2-13  
Affected: IC 22-12; IC 22-13; IC 22-14; IC 22-15; IC 36-7

**Sec. 88. Change Section 909.15 Control diagrams to read as follows: Identical control diagrams showing all devices in the system and identifying their location and function shall be maintained current and kept on file with the servicing fire department and in the fire command center in an approved manner and format.** (*Fire Prevention and Building Safety Commission; 675 IAC 13-2.4-88*)

**675 IAC 13-2.4-89 Section 909.18.8, Section 909.18.1, Section 909.18.8.2, Section 909.18.8.3, Sections 909.18.8.3.1 and Section 909.18.9; special inspections for smoke control, scope of testing, qualifications, reports, report filing, identification and documentation**

Authority: IC 22-13-2-2; IC 22-13-2-13  
Affected: IC 22-12; IC 22-13; IC 22-14; IC 22-15; IC 36-7

**Sec. 89. Delete sections 909.18.8 Special inspections for smoke control; 909.18.8.1 Scope of testing; 909.18.8.2 Qualifications; 909.18.8.3 Reports; 909.18.8.3.1 Report filing; 909.18.9 Identification and documentation and**

## Proposed Rules

substitute: See the General Administrative Rules (675 IAC 12-6-6(c)(10)(D)). (*Fire Prevention and Building Safety Commission; 675 IAC 13-2.4-89*)

**675 IAC 13-2.4-90 Section 909.19; system acceptance**

Authority: IC 22-13-2-2; IC 22-13-2-13

Affected: IC 22-12; IC 22-13; IC 22-14; IC 22-15; IC 36-7

Sec. 90. Delete the title and text of Section 909.19 System acceptance and substitute to read as follows: **909.19 Acceptance test.** Smoke removal systems shall be tested in accordance with the rules of the commission at the expense of the owner or owner's representative. When requested by the building official, such tests shall be conducted in the presence of the building official. Prior to conducting such tests, the building official shall be given at least 48-hour notice. It shall be unlawful to occupy portions of the structure until the required smoke removal system within that portion of the structure has been completed, successfully tested and fully operational with appropriate reports and other documentation provided to the building official. (*Fire Prevention and Building Safety Commission; 675 IAC 13-2.4-90*)

**675 IAC 13-2.4-91 Section 909.20; acceptance and testing**

Authority: IC 22-13-2-2; IC 22-13-2-13

Affected: IC 22-12; IC 22-13; IC 22-14; IC 22-15; IC 36-7

Sec. 91. Delete the title and text of Section 909.20.6.3 Acceptance and testing, and substitute to read as follows: **909.20.6.3 Acceptance test.** Mechanical ventilation systems shall be tested in accordance with the rules of the commission at the expense of the owner or owner's representative. When requested by the building official, such tests shall be conducted in the presence of the building official. Prior to conducting such tests, the building official shall be given at least 48-hour notice. It shall be unlawful to occupy portions of the structure until the mechanical ventilation system within that portion of the structure has been completed, successfully tested and fully operational. (*Fire Prevention and Building Safety Commission; 675 IAC 13-2.4-91*)

**675 IAC 13-2.4-92 Section 910.2.1; Groups F-1 and S-1**

Authority: IC 22-13-2-2; IC 22-13-2-13

Affected: IC 22-12; IC 22-13; IC 22-14; IC 22-15; IC 36-7

Sec. 92. Add an Exception to the end of Section 910.2.1 Groups F-1 and S-1 to read as follows: **Exception: Group S-1 Aircraft Hangers.** (*Fire Prevention and Building Safety Commission; 675 IAC 13-2.4-92*)

**675 IAC 13-2.4-93 Section 910.3.1.2; sprinklered buildings**

Authority: IC 22-13-2-2; IC 22-13-2-13

Affected: IC 22-12; IC 22-13; IC 22-14; IC 22-15; IC 36-7

Sec. 93. Delete Section 910.3.1.2 Sprinklered buildings and substitute to read as follows: Where installed in buildings provided with approved automatic sprinkler system, smoke and heat vents shall open by approved manual releases. The servicing fire department shall be consulted in determining location of such manual releases prior to the installation of the smoke and heat vents. (*Fire Prevention and Building Safety Commission; 675 IAC 13-2.4-93*)

**675 IAC 13-2.4-94 Section 910.3.4; curtain boards**

Authority: IC 22-13-2-2; IC 22-13-2-13

Affected: IC 22-12; IC 22-13; IC 22-14; IC 22-15; IC 36-7

Sec. 94. Add an Exception to the end of Section 910.3.4 Curtain boards to read as follows: **Exception:** Where areas of buildings are equipped with early suppression-fast response (ESFR) sprinklers, draft curtains shall not be provided within these areas. Draft curtains shall only be provided at the separation between the ESFR sprinklers and the conventional sprinklers and in other areas as required by this section. (*Fire Prevention and Building Safety Commission; 675 IAC 13-2.4-94*)

**675 IAC 13-2.4-95 Section 910.4; automatic sprinkler system**

Authority: IC 22-13-2-2; IC 22-13-2-13

Affected: IC 22-12; IC 22-13; IC 22-14; IC 22-15; IC 36-7

Sec. 95. Delete Section 910.4 and substitute to read as follows: In buildings protected throughout with an approved automatic sprinkler system, manually operated exhaust fans may be utilized for fire department mop-up operations. The exhaust rate shall be equal to 1 cfm per square foot of floor area. The fans shall be wired ahead of the main building disconnect switch. Manual controls for the fans shall be provided individually for each fan unit. The servicing fire department shall be consulted in determining the location of the controls for the exhaust fans. (*Fire Prevention and Building Safety Commission; 675 IAC 13-2.4-95*)

**675 IAC 13-2.4-96 Section 1001.2; minimum requirements**

Authority: IC 22-13-2-2; IC 22-13-2-13

Affected: IC 22-12; IC 22-13; IC 22-14; IC 22-15; IC 36-7

Sec. 96. Delete Section 1001.2 Minimum requirements and substitute to read as follows: See the General Administrative Rules (675 IAC 12). (*Fire Prevention and Building Safety Commission; 675 IAC 13-2.4-96*)

**675 IAC 13-2.4-97 Section 1002; definitions**

Authority: IC 22-13-2-2; IC 22-13-2-13

Affected: IC 22-12; IC 22-13; IC 22-14; IC 22-15; IC 36-7

Sec. 97. Add in Section 1002 the definition of ICC/ANSI A117.1 after the definition of HANDRAIL to read as

**follows: ICC/ANSI A117.1 means Chapter 11 of this code.** (*Fire Prevention and Building Safety Commission; 675 IAC 13-2.4-97*)

**675 IAC 13-2.4-98 Section 1003.1.1; size of doors**

Authority: IC 22-13-2-2; IC 22-13-2-13  
Affected: IC 22-12; IC 22-13; IC 22-14; IC 22-15; IC 36-7

**Sec. 98. Delete Exception 8 in Section 1003.1.1. Size of doors.** (*Fire Prevention and Building Safety Commission; 675 IAC 13-2.4-98*)

**675 IAC 13-2.4-99 Section 1003.2.2.4; increased occupant load**

Authority: IC 22-13-2-2; IC 22-13-2-13  
Affected: IC 22-12; IC 22-13; IC 22-14; IC 22-15; IC 36-7

**Sec. 99. Delete Section 1003.2.2.4 Increased occupant load.** (*Fire Prevention and Building Safety Commission; 675 IAC 13-2.4-99*)

**675 IAC 13-2.4-100 Section 1003.2.1.2.2; guards**

Authority: IC 22-13-2-2; IC 22-13-2-13  
Affected: IC 22-12; IC 22-13; IC 22-14; IC 22-15; IC 36-7

**Sec. 100. Change the third line of Exception 2 to Section 1003.2.1.2.2 to read as follows: “ systems, fire department access doors required by the Indiana Fire Code (675 IAC 22) that are not a required exit, or equipment, guards shall have”.** (*Fire Prevention and Building Safety Commission; 675 IAC 13-2.4-100*)

**675 IAC 13-2.4-101 Section 1003.2.13.1; general**

Authority: IC 22-13-2-2; IC 22-13-2-13  
Affected: IC 22-12; IC 22-13; IC 22-14; IC 22-15; IC 36-7

**Sec. 101. Delete in Section 1003.2.13.1 General, the words “one or more” and substitute the words “at least one”.** (*Fire Prevention and Building Safety Commission; 675 IAC 13-2.4-101*)

**675 IAC 13-2.4-102 Section 1003.3.1.2; doors**

Authority: IC 22-13-2-2; IC 22-13-2-13  
Affected: IC 22-12; IC 22-13; IC 22-14; IC 22-15; IC 36-7

**Sec. 102. Change the second paragraph of Section 1003.3.1.2 to read as follows: Doors shall swing in the direction of egress travel where the area served has an occupant load of 50 or more or is a high-hazard occupancy.** (*Fire Prevention and Building Safety Commission; 675 IAC 13-2.4-102*)

**675 IAC 13-2.4-103 Section 1003.3.1.4; floor elevation**

Authority: IC 22-13-2-2; IC 22-13-2-13  
Affected: IC 22-12; IC 22-13; IC 22-14; IC 22-15; IC 36-7

**Sec. 103. Change in Section 1003.3.1.4 Floor elevation, Exception 4 to read as follows: 4. Exterior decks, patios, or balconies that are part of a dwelling unit regulated under part 2 of Chapter 11 and have impervious surfaces, and**

**that are not more than 4 inches (102 mm) below the finished floor level of the adjacent interior space of the dwelling unit.** (*Fire Prevention and Building Safety Commission; 675 IAC 13-2.4-103*)

**675 IAC 13-2.4-104 Section 1003.3.1.7; door arrangement**

Authority: IC 22-13-2-2; IC 22-13-2-13  
Affected: IC 22-12; IC 22-13; IC 22-14; IC 22-15; IC 36-7

**Sec. 104. Change in Section 1003.3.1.7 Door arrangement, Exception 3 to read as follows: 3. Doors within individual dwelling units in Groups R-2 and R-3 as applicable in Section 101.2.** (*Fire Prevention and Building Safety Commission; 675 IAC 13-2.4-104*)

**675 IAC 13-2.4-105 Section 1003.3.1.8; locks and latches**

Authority: IC 22-13-2-2; IC 22-13-2-13  
Affected: IC 22-12; IC 22-13; IC 22-14; IC 22-15; IC 36-7

**Sec. 105. Change Section 1003.3.1.8 Locks and latches as follows:**

- (1) Delete Exception 2. 3.
- (2) Add Exception 5 to read as follows: 5. Licensed Health Care Facilities that comply with IC 22-11-17-2.5 by meeting the federal standards of certification for participation in a reimbursed program under either Title XVIII or Title XIX of the Federal Social Security Act.

(*Fire Prevention and Building Safety Commission; 675 IAC 13-2.4-105*)

**675 IAC 13-2.4-106 Section 1003.3.1.8.2; delayed egress locks**

Authority: IC 22-13-2-2; IC 22-13-2-13  
Affected: IC 22-12; IC 22-13; IC 22-14; IC 22-15; IC 36-7

**Sec. 106. Delete in Section 1003.3.1.8.2 Delayed egress locks, the Exception to item 4.** (*Fire Prevention and Building Safety Commission; 675 IAC 13-2.4-106*)

**675 IAC 13-2.4-107 Section 1003.3.3.3; stair treads and risers**

Authority: IC 22-13-2-2; IC 22-13-2-13  
Affected: IC 22-12; IC 22-13; IC 22-14; IC 22-15; IC 36-7

**Sec. 107. Change Section 1003.3.3.3 Stair treads and risers as follows:**

- (1) Delete Exception 5 and substitute to read as follows: 5. Within dwelling units in occupancies in Group R-3, as applicable in Section 101.2, and within dwelling units in occupancies in Group R-2, as applicable in Section 101.2, the maximum riser height shall be 8¼ inches (210 mm), the minimum tread depth shall be 9 inches (229 mm). A nosing not less than 0.75 inch (19.1 mm) but not more than 1.25 inches (32 mm) shall be provided on stairways with solid risers where the tread is less than 11 inches. In occupancies in Group U, which are accessory to an occupancy in Group R-3, as applicable in Section 101.2,

## Proposed Rules

the maximum riser height shall be 7.75 inches (197 mm) and the minimum tread depth shall be 10 inches (254 mm) and the nosing requirements shall remain the same as above.

(2) Delete Exception 6 and substitute to read: See the General Administrative Rules (675 IAC 12).

*(Fire Prevention and Building Safety Commission; 675 IAC 13-2.4-107)*

### 675 IAC 13-2.4-108 Section 1003.3.3.11.3; Group R-2 dwellings

Authority: IC 22-13-2-2; IC 22-13-2-13

Affected: IC 22-12; IC 22-13; IC 22-14; IC 22-15; IC 36-7

Sec. 108. Add an Exception to the end of Section 1003.3.3.11.3 to read as follows: Exception: Within Group R-2 dwelling units, the handgrip portion of handrails shall have a circular cross section of 1¼ inches (32 mm) minimum to 2⅞ inches (73 mm) maximum. Other handrail shapes that provide equivalent grasping surface are permissible. Edges shall have a minimum radius of ⅛ inch (3.2 mm). *(Fire Prevention and Building Safety Commission; 675 IAC 13-2.4-108)*

### 675 IAC 13-2.4-109 Section 1008.10; seat stability

Authority: IC 22-13-2-2; IC 22-13-2-13

Affected: IC 22-12; IC 22-13; IC 22-14; IC 22-15; IC 36-7

Sec. 109. Delete in Section 1008.10 Seat stability, the last sentence of Exception 4. *(Fire Prevention and Building Safety Commission; 675 IAC 13-2.4-109)*

### 675 IAC 13-2.4-110 Section 1009.6; exterior rescue access

Authority: IC 22-13-2-2; IC 22-13-2-13

Affected: IC 22-12; IC 22-13; IC 22-14; IC 22-15; IC 36-7

Sec. 110. Add Section 1009.6 Exterior rescue access to the end of Section 1009 to read as follows:

**1009.6 Exterior Rescue Access.** Exterior access for fire department use in performing rescue operations when emergency escape and rescue openings are required shall comply with Sections 1009.6.1 and 1009.6.2.

**1009.6.1** The exterior grade adjacent to emergency escape and rescue openings shall not have a slope of more than 2 inches in 12 inches. The grade requirement shall extend from the structure to a point which will allow the placement of a fire department ground ladder to the sill of the emergency escape and rescue opening when such ladder is placed at a 75 degree angle maximum from the horizontal plane. In no circumstances shall the required grade extend less than forty-four (44) inches from the structure.

**1009.6.2** No obstructions such as wire, trees, shrubs, signs, cornices, overhangs, awnings, canopies, parking or other features shall be permitted.

Exception: Canopies and similar types of building features may be used as a portion of the rescue access system, if the slope of the canopy or similar types of

building features does not exceed 2 inches in 12 inches, and access as required in Section 1009.6.1 is provided from the ground to the top edge of the canopy.

*(Fire Prevention and Building Safety Commission; 675 IAC 13-2.4-110)*

### 675 IAC 13-2.4-111 Chapter 11; accessibility

Authority: IC 22-13-2-2; IC 22-13-2-13

Affected: IC 22-12; IC 22-13; IC 22-14; IC 22-15; IC 36-7

Sec. 111. Delete Chapter 11 and substitute the following:

## CHAPTER 11 - PART 1 - ACCESSIBILITY FOR PUBLIC ACCOMMODATIONS AND COMMERCIAL FACILITIES

### 1.0 General.

**1.1 Purpose.** The purpose of this part is to implement a rule within the statutory authority of IC 22-13-2-2 and IC 22-13-4-1.5 that is compatible with Title III of the Americans with Disabilities Act of 1990 (42 U.S.C. 12181), which prohibits discrimination on the basis of disability and requires places of public accommodation and commercial facilities to be designed and constructed for accessibility by persons with a disability; requires that an alteration of an existing facility be made so that the alteration complies with the readily achievable barrier removal provisions of the Americans with Disabilities Act Accessibility Guidelines (28 CFR 36.101 et seq.); and allows the use of reasonable and cost-effective alternative means of public access or service if the alternative means are consistent with the Americans with Disabilities Act (42 U.S.C. 12181 et seq.).

### 1.2 Application.

(1) General. This part applies to the design and construction of any public accommodation or commercial facility.

(2) The requirements of this part obligate a public accommodation only with respect to the accommodation.

(3) The requirements of this part obligate a public accommodation only with respect to:

(a) a facility designed or constructed for use as a place of public accommodation; or

(b) a facility designed and constructed for use as a commercial facility.

(4) Part 1 applies to the design and construction of any private club, religious entity, and public entity. Private clubs, religious entities, and public entities shall be considered a place of public accommodation.

(5) General exceptions.

(a) In new construction, a person or entity is not required to meet fully the requirements of this rule where that person or entity can demonstrate that it is structurally impracticable to do so. Full compliance will be considered structurally impracticable only in those rare circumstances when the unique characteristics of terrain prevent the incorporation of accessibility features. If full compliance with the requirements of this rule is structurally impracticable, a person or entity shall comply with the requirements to the extent

it is not structurally impracticable. Any portion of the building or facility which can be made accessible shall comply to the extent that it is not structurally impracticable.

(b) Accessibility is not required to (i) observation galleries used primarily for security purposes; or (ii) in nonoccupiable spaces accessed only by ladders, catwalks, crawl spaces, very narrow passageways, or freight (nonpassenger) elevators, and frequented only by service personnel for repair purposes; such spaces include, but are not limited to, elevator pits, elevator penthouses, piping, or equipment catwalks.

### 1.3 Definitions.

**COMMERCIAL FACILITIES** means facilities:

- (1) whose operations will affect commerce;
- (2) that are intended for nonresidential use by a private entity;
- (3) that are Class 1 structures under IC 22-12-1-4; and
- (4) that are not facilities that are covered under Part 2 of Chapter 11.

**FACILITY** means all or any portion of Class 1 structures, site improvements, complexes, roads, walks, or parking lots on the site where the Class 1 structure is located.

**PLACE OF PUBLIC ACCOMMODATION** means a facility that falls within at least one (1) of the following categories:

- (1) An inn, hotel, motel, or other place of lodging, except for an establishment located within a building that contains not more than five (5) rooms for rent or hire and that is actually occupied by the proprietor of the establishment as the residence of the proprietor.
- (2) A restaurant, bar, or other establishment serving food or drink.
- (3) A motion picture house, theater, concert hall, stadium, or other place of exhibition or entertainment.
- (4) An auditorium, convention center, lecture hall, or other place of public gathering.
- (5) A bakery, grocery store, clothing store, hardware store, shopping center, or other sales or rental establishment.
- (6) A laundromat, dry cleaner, bank, barber shop, beauty shop, travel service, shoe repair service, funeral parlor, gas station, office of an accountant or lawyer, pharmacy, insurance office, professional office of a health care provider, hospital, or other service establishment.
- (7) A terminal, depot, or other station used for specified public transportation.
- (8) A museum, library, gallery, or other place of public display or collection.
- (9) A park, zoo, amusement park, or other place of recreation.
- (10) A nursery, elementary, secondary, undergraduate, or postgraduate private school, or other place of education.
- (11) A day care center, senior citizen center, homeless shelter, food bank, adoption agency, or other social service center establishment.

(12) A gymnasium, health spa, bowling alley, golf course, or other place of exercise or recreation.

(13) Private clubs.

(14) Religious entities.

(15) Public entities.

**PRIVATE CLUB** means a private club or establishment not in fact open to the public.

**PRIVATE ENTITY** means a person or entity other than a public entity.

**PUBLIC ACCOMMODATION** means a private entity that owns, leases (or leases to), or operates a place of public accommodation.

**PUBLIC ENTITY** means:

- (1) any state or local government; or
- (2) any department, agency, special purpose district, or other instrumentality of a state or states or local government.

**RELIGIOUS ENTITY** means a religious organization, including a place of worship.

### 2.1 Scope.

(a) Commercial facilities located in private residences.

(1) When a commercial facility is part of a private residence as new construction or as a change of occupancy, the portion of the residence used exclusively as a residence is not covered by this part, but the portion used exclusively in the operation of the commercial facility or that portion used both for the commercial facility and for residential purposes is covered by the new construction requirements of this part.

(2) The portion of the residence covered under paragraph (a)(1) of this section extends to those elements used to enter the commercial facility, including:

- (A) the homeowner's front sidewalk, if any;
- (B) the door or entryway and hallways; and
- (C) those portions of the residence, interior or exterior, available to or used by employees or visitors of the commercial facility, including rest rooms.

(b) Elevator exemption.

(1) For the purposes of this paragraph:

(A) **PROFESSIONAL OFFICE OF A HEALTH CARE PROVIDER** means a location where a person or entity regulated by the state to provide professional services related to the physical or mental health of an individual makes such services available to the public. The facility housing the professional office of a health care provider only includes floor levels housing at least one (1) health care provider or any floor level designed or intended for use by at least one (1) health care provider.

(B) **SHOPPING CENTER OR SHOPPING MALL** means either of the following:

- (i) A building housing five (5) or more sales or rental establishments.
- (ii) A series of buildings on a common site, either under common ownership or common control or developed either as one (1) project or as a series of

related projects, housing five (5) or more sales or rental establishments. For purposes of this section, places of public accommodation of the types listed in the definition of PLACE OF PUBLIC ACCOMMODATION subdivisions one (1) through twelve (12) in section 1.3 are considered sales or rental establishments. The facility housing a shopping center or shopping mall only includes floor levels housing at least one (1) sales or rental establishment or any floor level designed or intended for use by at least one (1) sales or rental establishment.

(2) This section does not require the installation of an elevator in a facility that is less than three (3) stories or has less than three thousand (3,000) square feet per story, except with respect to any facility that houses one (1) or more of the following:

(A) A shopping center, a shopping mall, or a professional office of a health care provider.

(B) A terminal, depot, or other station used for specified public transportation or an airport passenger terminal. In such a facility, any area housing passenger services, including boarding and disembarking, loading and unloading baggage claim, dining facilities, and other common areas open to the public, must be on an accessible route from an accessible entrance.

(3) The elevator exemption set forth in this paragraph (b) does not obviate or limit, in any way, the obligation to comply with the other accessibility requirements established in paragraph (a) of this section. For example, in a facility that houses a shopping center, a shopping mall, or a professional office of a health care provider, the floors that are above or below an accessible ground floor and that do not house sales or rental establishments or a professional office of a health care provider must meet the requirements of this section but for the elevator.

### SCOPE AND TECHNICAL REQUIREMENTS

3.1 Provisions for Adults. The specifications in these guidelines are based upon adult dimensions and anthropometrics, except for 11.1 through 11.10.4.

3.2 Dimensional Tolerances. All dimensions are subject to conventional building industry tolerances for field conditions.

3.3 Graphic Conventions. Graphic conventions are shown in Table 1. Dimensions that are not marked minimum or maximum are absolute, unless otherwise indicated in the text or captions.

3.4 Definitions applicable to Part 1 of this Chapter only:

**ACCESS AISLE** means an accessible pedestrian space between elements that provides clearances appropriate for use of the elements.

**ACCESSIBLE** means a site, building, facility, or portion thereof that complies with this part.

**ACCESSIBLE ELEMENT** means an element specified by this part.

**ACCESSIBLE ROUTE** means a continuous, unobstructed path connecting all accessible elements and spaces of a

building or facility. Interior accessible routes may include corridors, floors, ramps, elevators, lifts, and clear floor space at fixtures. Exterior accessible routes may include parking access aisles, curb ramps, crosswalks at vehicular ways, walks, ramps, and lifts within the site where the Class 1 structure is located.

**ACCESSIBLE SPACE** means space that complies with this part.

**ADAPTABILITY** means the ability of certain building spaces and elements, such as kitchen counters, sinks, and grab bars, to be added or altered so as to accommodate the needs of persons with or without disabilities or to accommodate the needs of persons with different types or degrees of disability.

**ADDITION** means all expansion, extension, or increase in the gross floor area of a building or facility.

**ADMINISTRATIVE AUTHORITY** means the state building commissioner or officer of a local unit of government empowered by law to administer and enforce the rules of the fire prevention and building safety commission. For the purposes of Industrialized Building Systems (675 IAC 15), **ADMINISTRATIVE AUTHORITY** means the state building commissioner.

**AREA OF RESCUE ASSISTANCE** means an area, which has direct access to an exit, where people who are unable to use stairs may remain temporarily in safety to await further instructions or assistance during emergency evacuation.

**ASSEMBLY AREA** means, for the purposes of Part 1, a room or space accommodating a group of individuals for recreational, educational, political, social, or amusement purposes, or for the consumption of food and drink.

**AUTOMATIC DOOR** means a door equipped with a power-operated mechanism and controls that open and close the door automatically upon receipt of a momentary actuating signal. The switch that begins the automatic cycle may be a photoelectric device, floor mat, or manual switch (see **POWER-ASSISTED DOOR**).

**BUILDING** means any structure used and intended for supporting or sheltering any use or occupancy.

**CIRCULATION PATH** means an exterior or interior way of passage from one (1) place to another for pedestrians, including, but not limited to, walks, hallways, courtyards, stairways, and stair landings.

**CLEAR** means unobstructed.

**CLEAR FLOOR SPACE** means the minimum unobstructed floor or ground space required to accommodate a single, stationary wheelchair and occupant.

**CLOSED CIRCUIT TELEPHONE** means a telephone with dedicated line(s) such as a house phone, courtesy phone, or phone that must be used to gain entrance to a facility.

**COMMON USE** means those interior and exterior rooms, spaces, or elements that are made available for the use of a restricted group of people, for example, occupants of a homeless shelter, the occupants of an office building, or the guests of such occupants.



**CROSS SLOPE** means the slope that is perpendicular to the direction of travel (see **RUNNING SLOPE**).

**CURB RAMP** means a short ramp cutting through a curb or built up to it.

**DETECTABLE WARNING** means a standardized surface feature built in or applied to walking surfaces or other elements to warn visually impaired people of hazards on a circulation path.

**DWELLING UNIT** means, for the purposes of Part 1, a single unit which provides a kitchen or food preparation area, in addition to rooms and spaces for living, bathing, sleeping, and the like. Dwelling units include:

- (1) a single family home or a town house used as a transient group home;
- (2) an apartment building used as a shelter;
- (3) guest rooms in a hotel that provide sleeping accommodations and food preparation areas; and
- (4) other similar facilities used on a transient basis.

For the purposes of Part 1, use of the term **DWELLING UNIT** does not imply the unit is used as a residence.

**EGRESS, MEANS OF** means, for the purposes of Part 1, a continuous and unobstructed way of exit travel from any point in a building or facility to a public way. A means of egress comprises vertical and horizontal travel and may include intervening room spaces, doorways, hallways, corridors, passageways, balconies, ramps, stairs, enclosures, lobbies, horizontal exits, courts, and yards. An accessible means of egress is one that complies with Part 1 and does not include stairs, steps, or escalators. Areas of rescue assistance or evacuation elevators may be included as part of accessible means of egress.

**ELEMENT** means an architectural or mechanical component of a building, facility, space, or site.

**ENTRANCE** means any access point to a building or portion of a building or facility used for the purpose of entering. An entrance includes the approach walk, the vertical access leading to the entrance platform, the entrance platform itself, vestibule if provided, the entry door(s) or gate(s), and the hardware of the entry door(s) or gate(s).

**FACILITY** means all or any portion of a Class 1 structure, site improvements, complexes, roads, walks, or parking lots on the site where the Class 1 structure is located.

**GROUND FLOOR** means, for the purposes of Part 1, any occupiable floor less than one (1) story above or below grade with direct access to grade. A building or facility always has at least one (1) ground floor and may have more than one (1) ground floor as where a split level entrance has been provided or where a building is built into a hillside.

**MARKED CROSSING** means a crosswalk or other identified path intended for pedestrian use in crossing a vehicular way, located on the site where the Class 1 building or structure is located.

**MEZZANINE OR MEZZANINE FLOOR** means, for the purposes of Part 1, that portion of a story which is an

intermediate floor level placed within the story and having occupiable space above and below its floor.

**MULTIFAMILY DWELLING** means any building containing more than two (2) dwelling units.

**OCCUPIABLE** means a room or enclosed space designed for human occupancy:

- (1) in which:
  - (A) individuals congregate for amusement, educational or similar purposes; or
  - (B) occupants are engaged at labor; and
- (2) which is equipped with means of egress, light, and ventilation.

**OPERABLE PART** means a part or a piece of equipment or appliance used to insert or withdraw objects, or to activate, deactivate, or adjust the equipment or appliance, for example, coin slot, push button, or handle.

**POWER-ASSISTED DOOR** means a door used for human passage with a mechanism that helps to open the door, or relieves the opening resistance of a door, upon the activation of a switch or a continued force applied to the door itself.

**PUBLIC USE** means interior or exterior rooms or spaces that are made available to the general public. Public use may be provided at a building or facility that is privately or publicly owned.

**RAMP** means, for the purposes of Part 1, a walking surface which has a running slope greater than 1:20.

**RUNNING SLOPE** means the slope that is parallel to the direction of travel (see **CROSS SLOPE**).

**SERVICE ENTRANCE** means an entrance intended primarily for delivery of goods or services.

**SIGNAGE** means displayed verbal, symbolic, tactile, and pictorial information.

**SITE** means a parcel of land bounded by a property line or a designated portion of a public right-of-way.

**SITE IMPROVEMENT** means landscaping, paving for pedestrian and vehicular ways, outdoor lighting, recreational facilities, and similar improvements added to a site.

**SLEEPING ACCOMMODATIONS** means rooms in which people sleep, for example, dormitory and hotel or motel guest rooms or suites.

**SPACE** means a definable area, such as room, toilet room, hall, assembly area, entrance, storage room, alcove, courtyard, or lobby.

**STORY** means, for the purposes of Part 1, that portion of a building included between the upper surface of a floor and the upper surface of the floor or roof next above. If such portion of a building does not include occupiable space, it is not considered a story for purposes of Part 1. There may be more than one (1) floor level within a story as in the case of a mezzanine or mezzanines.

**STRUCTURAL FRAME** means the structural frame shall be considered to be the columns and the girders, beams, trusses, and spandrels having direct connections to the columns and all other members which are essential to the stability of the building as a whole.

---

---

## Proposed Rules

---

---

**TACTILE** means an object that can be perceived using the sense of touch.

**TEXT TELEPHONE** means machinery or equipment that employs interactive graphic (i.e., typed) communications through the transmission of coded signals across the standard telephone network. Text telephones can include, for example, devices known as TDD's (telecommunication display devices or telecommunication devices for deaf persons) or computers.

**TRANSIENT LODGING** means a building, facility, or portion thereof, excluding in-patient medical care facilities, that contains one (1) or more dwelling units or sleeping accommodations. Transient lodging may include, but is not limited to, resorts, group homes, hotels, motels, and dormitories.

**VEHICULAR WAY** means a route intended for vehicular traffic, such as a street, driveway, or parking lot, within the site where a Class 1 structure is located.

**WALK** means an exterior pathway with a prepared surface intended for pedestrian use, including general pedestrian areas such as plazas and courts, within the site where a Class 1 structure is located.

### 4.0 Accessible Elements, Routes, and Spaces.

#### 4.1 Minimum Requirements.

##### 4.1.1 Application.

(1) **General.** All areas of newly designed or newly constructed buildings and facilities required to be accessible by section 4.1.2 and section 4.1.3.

(1) **Application Based on Building Use.** Special application sections 5 through 9 provide additional requirements for restaurants and cafeterias, medical care facilities, business and mercantile, libraries, and accessible transient lodging. When a building or facility contains more than one (1) use covered by a special application section, each portion shall comply with the requirements for that use.

(2) **Areas Used Only by Employees as Work Areas.** Areas that are used only as work areas shall be designed and constructed so that persons with a disability can approach, enter, and exit the areas. This part does not require that any areas used only as work areas be constructed to permit maneuvering within the work area or be constructed or equipped, such as racks or shelves, to be accessible.

(3) **Temporary Structures.** Chapter 11 covers temporary buildings or facilities as well as permanent facilities. Temporary buildings and facilities are not of permanent construction but are extensively used or are essential for public use for a period of time. Examples of temporary buildings or facilities covered by this rule include, but are not limited to, reviewing stands, temporary classrooms, bleacher areas, exhibit areas, temporary banking facilities, temporary health screening services, or temporary safe pedestrian passageways around a construction site. Structures, sites, and

equipment directly associated with the actual processes of construction, such as scaffolding, bridging, materials hoists, or construction trailers, are not included.

(4) **Accessibility is not required on:**

(A) observation galleries used primarily for security purposes; or

(B) in nonoccupiable spaces accessed only by ladders, catwalks, crawl spaces, very narrow passageways, or freight (nonpassenger) elevators and frequented only by service personnel for repair purposes; such spaces include, but are not limited to, elevator pits, elevator penthouses, piping, or equipment catwalks.

##### 4.1.2 Accessible Sites and Exterior Facilities: New Construction.

An accessible site shall meet the following minimum requirements:

(1) At least one (1) accessible route complying with section 4.3 shall be provided within the boundary of the site from public transportation stops, accessible parking spaces, passenger loading zones, if provided, and public streets or sidewalks to an accessible building entrance.

(2) At least one (1) accessible route complying with section 4.3 shall connect accessible buildings, accessible facilities, accessible elements, and accessible spaces that are on the same site.

(3) All objects that protrude from surfaces or posts into circulation paths shall comply with section 4.4.

(4) Ground surfaces along accessible routes and in accessible spaces shall comply with section 4.5.

(5) Reserved.

(6) If toilet facilities are provided on a site, then each such public or common use toilet facility shall comply with section 4.22. If bathing facilities are provided on a site, then each such public or common use bathing facility shall comply with section 4.23.

(7) **Building Signage.** Signs which designate permanent rooms and spaces shall comply with sections 4.30.1, 4.30.4, 4.30.5, and 4.30.6. Other signs which provide direction to, or information about, functional spaces of the building shall comply with sections 4.30.1, 4.30.2, 4.30.3, and 4.30.5.

Elements and spaces of accessible facilities which shall be identified by the international symbol of accessibility and which shall comply with section 4.30.7 are as follows:

(a) Parking spaces designated as reserved for persons with a disability.

(b) Accessible passenger loading zones.

(c) Accessible entrances when not all are accessible (inaccessible entrances shall have directional signage to indicate the route to the nearest accessible entrance).

(d) Accessible toilet and bathing facilities when not all are accessible.

##### 4.1.3 Accessible Buildings: Minimum Requirements.

Accessible buildings and facilities shall be designed and constructed to meet the following minimum requirements:

(1) At least one (1) accessible route complying with section 4.3 shall connect accessible building or facility entrances with all accessible spaces and elements within the building or facility.

(2) All objects that overhang or protrude into circulation paths shall comply with section 4.4.

(3) Ground and floor surfaces along accessible routes and in accessible rooms and spaces shall comply with section 4.5.

(4) Interior and exterior stairs connecting levels that are not connected by an elevator, ramp, or other accessible means of vertical access shall comply with section 4.9.

(5) One (1) passenger elevator complying with section 4.10 shall serve each level, including mezzanines, in all multistory buildings and facilities unless exempted below. If more than one (1) elevator is provided, each full passenger elevator shall comply with section 4.10.

**EXCEPTION 1:** Elevators are not required in facilities that are less than three (3) stories or that have less than three thousand (3,000) square feet per story unless the building is a shopping center, a shopping mall, or a professional office of a health care provider. The elevator exemption set forth in this paragraph does not obviate or limit in any way the obligation to comply with the other accessibility requirements established in section 4.1.3. For example, floors above or below the accessible ground floor must meet the requirements of this section, except for elevator service. If toilet or bathing facilities are provided on a level not served by an elevator, then toilet or bathing facilities must be provided on the accessible ground floor. In new construction, if a building or facility is eligible for this exemption but a full passenger elevator is nonetheless planned, that elevator shall meet the requirements of section 4.10 and shall serve each level in the building. A full passenger elevator that provides service from a garage to only one (1) level of a building or facility is not required to serve other levels.

**EXCEPTION 2:** Elevator pits, elevator penthouses, mechanical rooms, piping or equipment, and catwalks are exempted from this requirement.

**EXCEPTION 3:** Accessible ramps complying with section 4.8 may be used in lieu of an elevator.

**EXCEPTION 4:** Platform lifts (wheelchair lifts) complying with section 4.11 of this part may be used in lieu of an elevator only under the following conditions:

(a) To provide an accessible route to a performing area in an assembly occupancy.

(b) To comply with the wheelchair viewing position line-of-sight and dispersion requirements of section 4.33.3.

(c) To provide access to incidental occupiable spaces and rooms which are not open to the general public and which house no more than five (5) persons, including, but not limited to, equipment control rooms and projection booths.

(d) To provide access where existing site constraints or other constraints make use of a ramp or an elevator infeasible.

(6) Reserved.

(7) Doors:

(a) At each accessible entrance to a building or facility, at least one (1) door shall comply with section 4.13.

(b) Within a building or facility, at least one (1) door at each accessible space shall comply with section 4.13.

(c) Each door that is an element of an accessible route shall comply with section 4.13.

(d) Each door required by section 4.3.10, Egress, shall comply with section 4.13.

(8) At a minimum, the requirements in (a) and (b) below shall be satisfied independently:

(a)(i) At least fifty percent (50%) of all public entrances (excluding those in (2)(b) below) must be accessible. At least one (1) must be a ground floor entrance. Public entrances are any entrances that are not loading or service entrances.

(ii) Accessible entrances must be provided in a number at least equivalent to the number of exits required by chapter 10 of this code. (This paragraph does not require an increase in the total number of entrances planned for a facility.)

(iii) An accessible entrance must be provided to each tenancy in a facility, for example, individual stores in a strip shopping center.

One (1) entrance may be considered as meeting more than one (1) of the requirements in (a). Accessible entrances shall be entrances used by the majority of people visiting or working in the building.

(b)(i) In addition, if direct access is provided for pedestrians from an enclosed parking garage to the building, at least one (1) direct entrance from the garage to the building must be accessible.

(ii) If access is provided for pedestrians from a pedestrian tunnel or elevated walkway, one (1) entrance to the building from each tunnel or walkway must be accessible.

One (1) entrance may be considered as meeting more than one (1) of the requirements in (b).

(c) If the only entrance to a building, or tenancy in a facility, is a service entrance, that entrance shall be accessible.

(d) Entrances which are not accessible shall have directional signage complying with sections 4.30.1 and 4.30.5 which indicates the location of the nearest accessible entrance.

(9) In buildings or facilities, or portions of buildings or facilities, required to be accessible, accessible means of egress shall be provided in the same number as required for exits by chapter 10 of this code. Where a required exit from an occupiable level above or below a level of accessible exit discharge is not accessible, an area of rescue

## Proposed Rules

assistance shall be provided on each such level (in a number equal to that of inaccessible required exits). Areas of rescue assistance shall comply with section 4.3.11. A horizontal exit, meeting the requirements of chapter 10 of this code, shall satisfy the requirements for an area of rescue assistance (see section 4.3.11).

**EXCEPTION:** Areas of rescue assistance are not required in buildings or facilities having a supervised automatic fire suppression system throughout.

### (10) Drinking Fountains:

(a) Where only one (1) drinking fountain is provided on a floor, there shall be a drinking fountain which is accessible to individuals who use wheelchairs in accordance with section 4.15 and one (1) accessible to those who have difficulty bending or stooping.

(b) Where more than one (1) drinking fountain or water cooler is provided on a floor, fifty percent (50%) of those provided shall comply with section 4.15 and shall be on an accessible route.

(11) **Toilet Facilities:** If toilet rooms are provided, then each public and common use toilet room shall comply with section 4.22. Other toilet rooms provided for the use of occupants of specific spaces, such as a private toilet room for the occupant of a private office, shall be adaptable in conformance with CABO/ANSI A117.1 1992 as referenced in Chapter 11 - Part 2. If bathing rooms are provided, then each public and common use bathroom shall comply with section 4.23. Accessible toilet rooms and bathing facilities shall be on an accessible route.

### (12) Storage, Shelving, and Display Units:

(a) If fixed or built-in storage facilities, such as cabinets, shelves, closets, and drawers, are provided in accessible spaces, at least one (1) of each type provided shall contain storage space complying with section 4.25. Additional storage may be provided outside of the dimensions required by section 4.25.

(b) Shelves or display units allowing self-service by customers in mercantile occupancies shall be located on an accessible route complying with section 4.3. Requirements for accessible reach range do not apply.

(13) **Controls and operating mechanisms** in accessible spaces, along accessible routes, or as parts of accessible elements, for example, light switches and dispenser controls, shall comply with section 4.27.

(14) If emergency warning systems are provided, then they shall include both audible alarms and visual alarms complying with section 4.28. Sleeping accommodations required to comply with section 9.3 shall have an alarm system complying with 4.28.

(15) Reserved.

### (16) Building Signage:

(a) Signs which designate permanent rooms and spaces shall comply with sections 4.30.1, 4.30.4, 4.30.5, and 4.30.6.

(b) Other signs which provide direction to or informa-

tion about functional spaces of the building shall comply with sections 4.30.1, 4.30.2, 4.30.3, and 4.30.5.

**EXCEPTION:** Building directories, menus, and all other signs which are temporary are not required to comply.

### (17) Public Telephones:

(a) If public pay telephones, public closed circuit telephones, or other public telephones are provided, then they shall comply with sections 4.31.2 through 4.31.8 to the extent required by the following table:

<u>Number of Each Type of Telephone Provided on Each Floor</u>	<u>Number of Telephones Required to Comply With Sections 4.31.2 Through 4.31.8<sup>1</sup></u>
1 or more single unit	1 per floor
1 bank <sup>2</sup>	1 per floor
2 or more banks <sup>2</sup>	1 per bank. Accessible unit may be installed as a single unit in proximity (either visible or with signage) to the bank. At least 1 public telephone per floor shall meet the requirements for a forward reach telephone <sup>3</sup> .

<sup>1</sup>Additional public telephones may be installed at any height. Unless otherwise specified, accessible telephones may be either forward or side reach telephones.

<sup>2</sup>A bank consists of two (2) or more adjacent public telephones, often installed as a unit.

<sup>3</sup>**EXCEPTION:** For exterior installations only, if dial tone first service is available, then a side reach telephone may be installed instead of the required forward reach telephone (i.e., one (1) telephone in proximity to each bank shall comply with section 4.31).

(b) All telephones required to be accessible and complying with sections 4.31.2 through 4.31.8 shall be equipped with a volume control. In addition, twenty-five percent (25%), but never less than one (1), of all other public telephones provided shall be equipped with a volume control and shall be dispersed among all types of public telephones, including closed circuit telephones, throughout the building or facility. Signage complying with applicable provisions of section 4.30.7 shall be provided.

(c) The following shall be provided in accordance with 4.31.9:

(i) If a total number of four (4) or more public pay telephones (including both interior and exterior phones) is provided at a site, and at least one (1) is in an interior location, then at least one (1) interior public text telephone shall be provided.

(ii) If an interior public pay telephone is provided in a stadium or arena, in a convention center, in a hotel with a convention center, or in a covered mall, at least one (1) interior public text telephone shall be provided in the facility.

(iii) If a public pay telephone is located in or adjacent

to a hospital emergency room, hospital recovery room, or hospital waiting room, one (1) public text telephone shall be provided at each such location.

(d) Where a bank of telephones in the interior of a building consists of three (3) or more public pay telephones, at least one (1) public pay telephone in each such bank shall be equipped with a shelf and outlet in compliance with section 4.31.9(2).

(18) If fixed or built-in seating or tables (including, but not limited to, study carrels and student laboratory stations), are provided in accessible public or common use areas, at least five percent (5%), but not less than one (1), of the fixed or built-in seating areas or tables shall comply with section 4.32. An accessible route shall lead to and through such fixed or built-in seating areas or tables.

(19) Assembly Areas:

(a) Places of assembly with fixed seating accessible wheelchair locations shall comply with sections 4.33.2, 4.33.3, and 4.33.4 and shall be provided consistent with the following table:

Capacity of Seating in Assembly Areas	Number of Required Wheelchair Locations
4 to 25	1
26 to 50	2
51 to 300	4
301 to 500	6
Over 500	6, plus 1 additional space for each total seating capacity increase of 100

In addition, one percent (1%), but not less than one (1), of all fixed seats shall be aisle seats with no armrests on the aisle side, or removable or folding armrests on the aisle side. Each such seat shall be identified by a sign or marker. Signage notifying patrons of the availability of such seats shall be posted at the ticket office. Aisle seats are not required to comply with section 4.33.4.

(b) This paragraph applies to assembly areas where audible communications are integral to the use of the space (e.g., concert and lecture halls, playhouses and movie theaters, and meeting rooms, etc.). Such assembly areas, if (1) they accommodate at least fifty (50) persons, or if they have audio-amplification systems, and (2) they have fixed seating, shall have a permanently installed assistive listening system complying with section 4.33. For other assembly areas, a permanently installed assistive listening system, or an adequate number of electrical outlets or other supplementary wiring necessary to support a portable assistive listening system shall be provided. The minimum number of receivers to be provided shall be equal to four percent (4%) of the total number of seats, but in no case less than two (2). Signage complying with applicable provisions of section 4.30 shall be installed to

notify patrons of the availability of a listening system. (20) Where automated teller machines (ATMs) are provided, each ATM shall comply with the requirements of section 4.34 except where two (2) or more are provided at a location, then only one (1) must comply.

**EXCEPTION:** Drive-up-only automated teller machines are not required to comply with sections 4.27.2, 4.27.3, and 4.34.3.

(21) Where dressing and fitting rooms are provided for use by the general public, patients, customers, or employees, five percent (5%), but never less than one (1), of the dressing rooms for each type of use within each cluster of dressing rooms shall be accessible and shall comply with section 4.35. Examples of types of dressing rooms are those serving different genders or distinct and different functions as in different treatment or examination facilities.

4.1.4 Reserved.

4.1.5 Accessible Buildings: Additions. Each addition to an existing building or facility shall be regarded as an alteration. Each space or element added to the existing building or facility shall comply with the applicable provisions of sections 4.1.1 to 4.1.3. Minimum Requirements (for New Construction) and the applicable technical specifications of sections 4.2 through 4.35 and sections 5 through 9.

4.1.6 Reserved.

4.1.7 Reserved.

4.2 Space Allowable and Reach Ranges.

4.2.1 Wheelchair Passage Width. The minimum clear width for single wheelchair passage shall be thirty-two (32) inches (eight hundred fifteen (815) millimeters) at a point and thirty-six (36) inches (nine hundred fifteen (915) millimeters) continuously (see Fig. 1 and 24(e)).

4.2.2 Width for Wheelchair Passing. The minimum width for two (2) wheelchairs to pass is sixty (60) inches (one thousand five hundred twenty-five (1,525) millimeters) (see Fig. 2).

4.2.3 Wheelchair Turning Spaces. The space required for a wheelchair to make a one hundred eighty (180) degree turn is a clear space of sixty (60) inches (one thousand five hundred twenty-five (1,525) millimeters) diameter (see Fig. 3(a)) or a T-shaped space (see Fig. 3(b)).

4.2.4 Clear Floor or Ground Space for Wheelchairs.

4.2.4.1 Size and Approach. The minimum clear floor or ground space required to accommodate a single, stationary wheelchair and occupant is thirty (30) inches by forty-eight (48) inches (seven hundred sixty (760) millimeters by one thousand two hundred twenty (1,220) millimeters) (see Fig. 4(a)). The minimum clear floor or ground space for wheelchairs may be positioned for forward or parallel approach to an object (see Fig. 4(b) and 4(c)). Clear floor or ground space for wheelchairs may be part of the knee space required under some objects.

4.2.4.2 Relationship of Maneuvering Clearance to Wheelchair Spaces. One (1) full unobstructed side of the clear

floor or ground space for a wheelchair shall adjoin or overlap an accessible route or adjoin another wheelchair clear floor space. If a clear floor space is located in an alcove or otherwise confined on all or part of three (3) sides, additional maneuvering clearances shall be provided as shown in Fig. 4(d) and 4(e).

**4.2.4.3 Surfaces for Wheelchair Spaces.** Clear floor or ground spaces for wheelchairs shall comply with section 4.5.

**4.2.5 Forward Reach.** If the clear floor space only allows forward approach to an object, the maximum high forward reach allowed shall be forty-eight (48) inches (one thousand two hundred twenty (1,220) millimeters) (see Fig. 5(a)). The minimum low forward reach is fifteen (15) inches (three hundred eighty (380) millimeters). If the high forward reach is over an obstruction, reach and clearances shall be as shown in Fig. 5(b).

**4.2.6 Side Reach.** If the clear floor space allows parallel approach by a person in a wheelchair, the maximum high side reach allowed shall be fifty-four (54) inches (one thousand three hundred seventy (1,370) millimeters) and the low side reach shall be no less than nine (9) inches (two hundred thirty (230) millimeters) above the floor (Fig. 6(a) and 6(b)). If the side reach is over an obstruction, the reach and clearances shall be as shown in Fig. 6(c).

### 4.3 Accessible Route.

**4.3.1 General.** All walks, halls, corridors, aisles, sky walks, tunnels, and other spaces that are part of an accessible route shall comply with section 4.3.

#### 4.3.2 Location.

(1) At least one (1) accessible route within the boundary of the site shall be provided from public transportation stops, accessible parking and accessible passenger loading zones, and public streets or sidewalks to the accessible building entrance they serve. The accessible route shall coincide with the route for the general public.

(2) At least one (1) accessible route shall connect accessible buildings, facilities, elements, and spaces that are on the same site.

(3) At least one (1) accessible route shall connect accessible building or facility entrances with all accessible spaces and elements and with all accessible dwelling units within the building or facility.

(4) An accessible route shall connect at least one (1) accessible entrance of each accessible dwelling unit with those exterior and interior spaces and facilities that serve the accessible dwelling unit.

**4.3.3 Width.** The minimum clear width of an accessible route shall be thirty-six (36) inches (nine hundred fifteen (915) millimeters) except at doors (see sections 4.13.5 and 4.13.6). If a person in a wheelchair must make a turn around an obstruction, the minimum clear width of the accessible route shall be as shown in Fig. 7(a) and 7(b).

**4.3.4 Passing Spaces.** If an accessible route has less than sixty (60) inches (one thousand five hundred twenty-five (1,525) millimeters) clear width, then passing spaces at least

sixty (60) inches by sixty (60) inches (one thousand five hundred twenty-five (1,525) millimeters by one thousand five hundred twenty-five (1,525) millimeters) shall be located at reasonable intervals not to exceed two hundred (200) feet (sixty-one (61) meters). A T-intersection of two (2) corridors or walks is an acceptable passing place.

**4.3.5 Head Room.** Accessible routes shall comply with section 4.4.2.

**4.3.6 Surface Textures.** The surface of an accessible route shall comply with section 4.5.

**4.3.7 Slope.** An accessible route with a running slope greater than 1:20 is a ramp and shall comply with section 4.8. The cross slope of an accessible route shall not exceed 1:50.

**4.3.8 Changes in Levels.** Changes in levels along an accessible route shall comply with section 4.5.2. If an accessible route has changes in level greater than one-half (½) inch (thirteen (13) millimeters), then a curb ramp, ramp, elevator, or elevator platform lift (as permitted in section 4.1.3) shall be provided that complies with section 4.7, 4.8, 4.10, or 4.11, respectively. An accessible route does not include stairs, steps, or escalators. See definition of "EGRESS, MEANS OF" in section 3.5.

**4.3.9 Doors.** Doors along an accessible route shall comply with section 4.13.

**4.3.10 Egress.** Accessible routes serving any accessible space or element shall also serve as a means of egress for emergencies or connect to an accessible area of rescue assistance.

#### 4.3.11 Areas of Rescue Assistance.

**4.3.11.1 Location and Construction.** An area of rescue assistance shall be one (1) of the following:

(1) A portion of a stairway landing within a smoke-proof enclosure.

(2) A portion of an exterior exit balcony located immediately adjacent to an exit stairway when the balcony complies with the requirements for exterior exit balconies in chapter 10 of this code. Openings to the interior of the building located within twenty (20) feet (six (6) meters) of the area of rescue assistance shall be protected with fire assemblies having a three-fourths (¾) hour fire protection rating.

(3) A portion of a one (1) hour fire-resistive corridor located immediately adjacent to an exit enclosure.

(4) A vestibule located immediately adjacent to an exit enclosure and constructed to the same fire-resistive standards as required for corridors and openings.

(5) A portion of a stairway landing within an exit enclosure which is vented to the exterior and is separated from the interior of the building with not less than one (1) hour fire-resistive doors.

(6) An area or a room which is separated from other portions of the building by a smoke barrier. Smoke barriers shall have a fire-resistive rating of not less than one (1) hour and shall completely enclose the area or room. Doors in the smoke barrier shall be tight-fitting smoke and draft control assemblies having a fire-protec-

tion rating of not less than twenty (20) minutes and shall be self-closing or automatic closing. The area or room shall be provided with an exit directly to an exit enclosure. Where the room or area exits into an exit enclosure, which is required to be more than one (1) hour fire-resistive construction, the room or area shall have the same fire-resistive construction, including the same opening protection, as required for the adjacent exit.

(7) An elevator lobby when elevator shafts and adjacent lobbies are pressurized as required for smokeproof enclosures by chapter 10 of this code and when complying with requirements herein for size, communication, and signage. Such pressurization system shall be activated by smoke detectors on each floor. Pressurization equipment and its duct work within the building shall be separated from other portions of the building by a minimum two (2) hour fire-resistive construction.

(8) The area immediately adjacent to a horizontal exit that affords safety from fire or smoke coming from the area which escape is made.

**4.3.11.2 Size.** Each area of rescue assistance shall provide at least two (2) accessible areas each being not less than thirty (30) inches by forty-eight (48) inches (seven hundred sixty (760) millimeters by one thousand two hundred twenty (1,220) millimeters). The area of rescue assistance shall not encroach on any required exit width. The total number of such thirty (30) inch by forty-eight (48) inch (seven hundred sixty (760) millimeters by one thousand two hundred twenty (1,220) millimeters) areas per story shall be not less than one (1) for every two hundred (200) persons of calculated occupant load served by the area of rescue assistance.

**EXCEPTION:** The number of thirty (30) inch by forty-eight (48) inch (seven hundred sixty (760) millimeters by one thousand two hundred twenty (1,220) millimeters) areas may be one (1) for each area of rescue assistance on floors where the occupant load is less than two hundred (200).

**4.3.11.3 Stairway Width.** Each stairway adjacent to an area of rescue assistance shall have a minimum clear width of forty-eight (48) inches between handrails.

**4.3.11.4 Two-way Communication.** A method of two-way communication, with both visible and audible signals, shall be provided between each area of rescue assistance and the primary entry.

**4.3.11.5 Identification.** Each area of rescue assistance shall be identified by a sign which states "AREA OF RESCUE ASSISTANCE" and display the international symbol of accessibility. The sign shall be illuminated when exit sign illumination is required by chapter 10 of this code. Signage shall also be installed at all inaccessible exits and where otherwise necessary to clearly indicate the direction to areas of rescue assistance. In each area of rescue assistance, instructions on the use of the area under emergency conditions shall be posted adjoining the two-way communication system.

**4.4 Protruding Objects.**

**4.4.1 General.** Objects projecting from walls, for example, telephones, with their leading edges between twenty-seven (27) inches and eighty (80) inches (six hundred eighty-five (685) millimeters and two thousand thirty (2,030) millimeters) above the finished floor shall protrude no more than four (4) inches (one hundred (100) millimeters) into walks, halls, corridors, passageways, or aisles (see Fig. 8(a)). Objects mounted with their leading edges at or below twenty-seven (27) inches (six hundred eighty-five (685) millimeters) above the finished floor may protrude any amount (see Fig. 8(a) and (b)). Free-standing objects mounted on posts or pylons may overhang twelve (12) inches (three hundred five (305) millimeters) maximum from twenty-seven (27) inches to eighty (80) inches (six hundred eighty-five (685) millimeters to two thousand thirty (2,030) millimeters) above the ground or finished floor (see Fig. 8(c) and 8(d)). Protruding objects shall not reduce the clear width of an accessible route or maneuvering space (see Fig. 8(e)).

**4.4.2 Head Room.** Walks, halls, corridors, passageways, aisles, or other circulation spaces shall have eighty (80) inches (two thousand thirty (2030) millimeters) minimum clear head room (see Fig. 8(a)). If vertical clearance of an area adjoining an accessible route is reduced to less than eighty (80) inches (nominal dimension), a barrier to warn blind or visually impaired persons shall be provided (see Fig. 8(c-1)).

**4.5 Ground and Floor Surfaces.**

**4.5.1 General.** Ground and floor surfaces along accessible routes and in accessible rooms and spaces, including floors, walks, ramps, stairs, and curb ramps, shall be stable, firm, and slip-resistant and shall comply with section 4.5.

**4.5.2 Changes in Level.** Changes in level up to one-fourth (1/4) inch (six (6) millimeters) may be vertical and without edge treatment (see Fig. 7(c)). Changes in level between one-fourth (1/4) inch and one-half (1/2) inch (six (6) millimeters and thirteen (13) millimeters) shall be beveled with a slope no greater than 1:2 (see Fig. 7(d)). Changes in level greater than one-half (1/2) inch (thirteen (13) millimeters) shall be accomplished by means of a ramp that complies with section 4.7 or 4.8.

**4.5.3 Carpet.** If carpet or carpet tile is used on a ground or floor surface, then it shall be securely attached; have a firm cushion, pad, or backing, or no cushion or pad; and have a level loop, textured loop, level cut pile, or level cut/uncut pile texture. The maximum pile thickness shall be one-half (1/2) inch (thirteen (13) millimeters) (see Fig. 8(f)). Exposed edges of carpet shall be fastened to floor surfaces and have trim along the entire length of the exposed edge. Carpet edge trim shall comply with 4.5.2.

**4.5.4 Gratings.** If gratings are located in walking surfaces, then they shall have spaces no greater than one-half (1/2) inch (thirteen (13) millimeters) wide in one (1) direction (see Fig. 8(g)). If gratings have elongated openings, then they

shall be placed so that the long dimension is perpendicular to the dominant direction of travel (see Fig. 8(h)).

#### 4.6 Parking and Passenger Loading Zones.

4.6.1 Parking spaces required to be accessible by 4.1 shall comply with IC 5-16-9.

4.6.2 Reserved.

4.6.3 Reserved.

4.6.4 Reserved.

4.6.5 Vertical Clearance. Provide minimum vertical clearance of one hundred fourteen (114) inches (two thousand eight hundred ninety-five (2,895) millimeters) at accessible passenger loading zones and along at least one (1) vehicle access route to such areas from site entrance(s) and exit(s).

4.6.6 Passenger Loading Zones. Passenger loading zones shall provide an access aisle at least sixty (60) inches (one thousand five hundred twenty-five (1,525) millimeters) wide and twenty (20) feet (two hundred forty (240) inches) (six thousand one hundred (6,100) millimeters) long adjacent and parallel to the vehicle pull-up space (see Fig. 10). If there are curbs between the access aisle and the vehicle pull-up space, then a curb ramp complying with section 4.7 shall be provided. Vehicle standing spaces and access aisles shall be level with surface slopes not exceeding 1:50 (two percent (2%)) in all directions, and provide minimum vertical clearance of one hundred fourteen (114) inches (two thousand eight hundred ninety-five (2,895) millimeters) at accessible passenger loading zones and along at least one (1) vehicle access route to such areas from site entrance(s) and exit(s).

#### 4.7 Curb Ramps.

4.7.1 Location. Curb ramps complying with section 4.7 shall be provided wherever an accessible route crosses a curb within the site where a Class 1 building or structure is located.

4.7.2 Slope. Slopes of curb ramps shall comply with section 4.8.2. The slope shall be measured as shown in Fig. 11. Transitions from ramps to walks, gutters, or streets shall be flush and free of abrupt changes. Maximum slopes of adjoining gutters, road surface immediately adjacent to the curb ramp, or accessible route shall not exceed 1:20.

4.7.3 Width. The minimum width of a curb ramp shall be thirty-six (36) inches (nine hundred fifteen (915) millimeters), exclusive of flared sides.

4.7.4 Surface. Surfaces of curb ramps shall comply with section 4.5.

4.7.5 Sides of Curb Ramps. If a curb ramp is located where pedestrians must walk across the ramp, or where it is not protected by handrails or guardrails, it shall have flared sides; the maximum slope of the flare shall be 1:10 (see Fig. 12(a)). Curb ramps with returned curbs may be used where pedestrians would not normally walk across the ramp (see Fig. 12(b)).

4.7.6 Built-up Curb Ramps. Built-up curb ramps shall be located so that they do not project into vehicular traffic lanes (see Fig. 13).

4.7.7 Reserved.

4.7.8 Obstructions. Curb ramps shall be located or protected to prevent their obstruction by parked vehicles.

4.7.9 Location at Marked Crossings. Curb ramps at marked crossings shall be wholly contained within the markings, excluding any flared sides (see Fig. 15).

4.7.10 Diagonal Curb Ramps. If diagonal (or corner type) curb ramps have returned curbs or other well defined edges, such edges shall be parallel to the direction of pedestrian flow. The bottom of diagonal curb ramps shall have forty-eight (48) inches (one thousand two hundred twenty (1,220) millimeters) minimum clear space as show in Fig. 15(c) and (d). If diagonal curb ramps are provided at marked crossings, the forty-eight (48) inches (one thousand two hundred twenty (1,220) millimeters) clear space shall be within the markings (see Fig. 15(c) and (d)). If diagonal curb ramps have flared sides, they shall also have at least a twenty-four (24) inch (six hundred ten (610) millimeters) long segment of straight curb located on each side of the curb ramp and within the marked crossing (see Fig. 15(c)).

4.7.11 Islands. Any raised islands in crossings on the site where a Class 1 structure is located shall be cut through level with the street or have curb ramps at both sides and a level area at least forty-eight (48) inches (one thousand two hundred twenty (1,220) millimeters) long between the curb ramps in the part of the island intersected by the crossing (see Fig. 15(a) and (b)).

#### 4.8 Ramps.

4.8.1 General. Any part of an accessible route with a slope greater than 1:20 shall be considered a ramp and shall comply with section 4.8.

4.8.2 Slope and Rise. The least possible slope shall be used for any ramp. The maximum slope of a ramp shall be 1:12. The maximum rise for any run shall be thirty (30) inches (seven hundred sixty (760) millimeters) (see Fig. 16).

4.8.3 Clear Width. The minimum clear width of a ramp shall be thirty-six (36) inches (nine hundred fifteen (915) millimeters).

4.8.4 Landings. Ramps shall have level landings at bottom and top of each ramp and each ramp run. Landings shall have the following features:

- (1) The landing shall be at least as wide as the ramp run leading to it.
- (2) The landing length shall be a minimum of sixty (60) inches (one thousand five hundred twenty-five (1,525) millimeters) clear.
- (3) If ramps change direction at landings, the minimum landing size shall be sixty (60) inches by sixty (60) inches (one thousand five hundred twenty-five (1,525) millimeters by one thousand five hundred twenty-five (1,525) millimeters).
- (4) If a doorway is located at a landing, then the area in front of the doorway shall comply with section 4.13.6.

4.8.5 Handrails. If a ramp run has a rise greater than six (6) inches (one hundred fifty (150) millimeters) or a horizontal



projection greater than seventy-two (72) inches (one thousand eight hundred thirty (1,830) millimeters), then it shall have handrails on both sides. Handrails are not required on curb ramps or adjacent to seating in assembly areas.

Handrails shall comply with section 4.26 and shall have the following features:

- (1) Handrails shall be provided along both sides of ramp segments. The inside handrail on switchback or dogleg ramps shall always be continuous.
- (2) If handrails are not continuous, they shall extend at least twelve (12) inches (three hundred five (305) millimeters) beyond the top and bottom of the ramp segment and shall be parallel with the floor or ground surface (see Fig. 17).
- (3) The clear space between the handrail and the wall shall be one and one-half (1½) inches (thirty-eight (38) millimeters).
- (4) Gripping surfaces shall be continuous.
- (5) Top of handrail gripping surfaces shall be mounted between thirty-four (34) inches and thirty-eight (38) inches (eight hundred sixty-five (865) millimeters and nine hundred sixty-five (965) millimeters) above ramp surfaces.
- (6) Ends of handrails shall be either rounded or returned smoothly to floor, wall, or post.
- (7) Handrails shall not rotate within their fittings.

**4.8.6 Cross Slope and Surfaces.** The cross slope of ramp surfaces shall be no greater than 1:50. Ramp surfaces shall comply with section 4.5.

**4.8.7 Edge Protection.** Ramps and landings with drop-offs shall have curbs, walls, railings, or projecting surfaces that prevent people from slipping off the ramp. Curbs shall be a minimum of two (2) inches (fifty (50) millimeters) high (see Fig. 17).

**4.8.8 Outdoor Conditions.** Outdoor ramps and their approaches shall be designed so that water will not accumulate on walking surfaces.

**4.9 Stairs.**

**4.9.1 Minimum Number.** Stairs required to be accessible by section 4.1 shall comply with section 4.9.

**4.9.2 Treads and Risers.** On any given flight of stairs, all steps shall have uniform riser heights and uniform tread widths. Stair treads shall be no less than eleven (11) inches (two hundred eighty (280) millimeters) wide measured from riser to riser (see Fig. 18(a)). Open risers are not permitted.

**4.9.3 Nosings.** The undersides of nosings shall not be abrupt. The radius of curvature at the leading edge of the tread shall be no greater than one-half (½) inch (thirteen (13) millimeters). Risers shall be sloped or the underside of the nosing shall have an angle not less than sixty (60) degrees from the horizontal. Nosings shall project no more than one and one-half (1½) inches (thirty-eight (38) millimeters) (see Fig. 18).

**4.9.4 Handrails.** Stairways shall have handrails at both sides of all stairs. Handrails shall comply with section 4.26 and shall have the following features:

- (1) Handrails shall be continuous along both sides of stairs. The inside handrail on switchback or dogleg stairs shall always be continuous (see Fig. 19(a) and Fig. 19(b)).
- (2) If handrails are not continuous, they shall extend at least twelve (12) inches (three hundred five (305) millimeters) beyond the top riser and at least twelve (12) inches (three hundred five (305) millimeters) plus the width of one (1) tread beyond the bottom riser. At the top, the extension shall be parallel with the floor or ground surface. At the bottom, the handrail shall continue to slope for a distance of the width of one (1) tread from the bottom riser; the remainder of the extension shall be horizontal (see Fig. 19(c) and Fig. 19(d)). Handrail extensions shall comply with section 4.4.
- (3) The clear space between handrails and wall shall be one and one-half (1½) inches (thirty-eight (38) millimeters).
- (4) Gripping surfaces shall be uninterrupted by newel posts, other construction elements, or obstructions.
- (5) Top of handrail gripping surfaces shall be mounted between thirty-four (34) inches and thirty-eight (38) inches (eight hundred sixty-five (865) millimeters and nine hundred sixty-five (965) millimeters) above stair nosings.
- (6) Ends of handrails shall be either rounded or returned smoothly to floor, wall, or post.
- (7) Handrails shall not rotate within their fittings.

**4.9.5 Reserved.**

**4.9.6 Outdoor Conditions.** Outdoor stairs and their approaches shall be designed so that water will not accumulate on walking surfaces.

**4.10 Elevators.**

**4.10.1 General.** Accessible elevators shall be on an accessible route and shall comply with section 4.10 and with the Indiana Safety Code for Elevators, Escalators, Manlifts, and Hoists (675 IAC 21). Freight elevators shall not be considered as meeting the requirements of this section unless the only elevators provided are used as combination passenger and freight elevators for the public and employees.

**4.10.2 Automatic Operation.** Elevator operation shall be automatic. Each car shall be equipped with a self-leveling feature that will automatically bring the car to floor landings within a tolerance of one-half (½) inch (thirteen (13) millimeters) under rated loading to zero (0) loading conditions. This self-leveling feature shall be automatic and independent of the operating device and shall correct the overtravel or undertravel.

**4.10.3 Hall Call Buttons.** Call buttons in elevator lobbies and halls shall be centered at forty-two (42) inches (one thousand sixty-five (1,065) millimeters) above the floor. Such call buttons shall have visual signals to indicate when each call is registered and when each is answered. Call buttons shall be a minimum of three-fourths (¾) inch (nineteen (19) millimeters) in the smallest dimension. The button designating the up direction shall be on top (see Fig. 20). Buttons shall be raised or flush. Objects mounted

---

---

## Proposed Rules

---

---

beneath hall call buttons shall not project into the elevator lobby more than four (4) inches (one hundred (100) millimeters).

**4.10.4 Hall Lanterns.** A visible and audible signal shall be provided at each hoistway entrance to indicate which car is answering a call. Audible signals shall sound once for the up direction and twice for the down direction or shall have verbal annunciators that say “up” or “down”. Visible signals shall have the following features:

(1) Hall lantern fixtures shall be mounted so that their centerline is at least seventy-two (72) inches (one thousand eight hundred thirty (1,830) millimeters) above the lobby floor (see Fig. 20).

(2) Visual elements shall be at least two and one-half (2½) inches (sixty-four (64) millimeters) in the smallest dimension.

(3) Signals shall be visible from the vicinity of the hall call button (see Fig. 20). In-car lanterns located in cars, visible from the vicinity of hall call buttons, and conforming to the requirements in subsections (1) and (2) above, shall be acceptable.

**4.10.5 Raised and Braille Characters on Hoistway Entrances.** All elevator hoistway entrances shall have raised and braille floor designations provided on both jambs. The centerline of the characters shall be sixty (60) inches (one thousand five hundred twenty-five (1,525) millimeters) above finish floor. Such characters shall be two (2) inches (fifty (50) millimeters) high and shall comply with section 4.30.4. Permanently applied plates are acceptable if they are permanently fixed to the jambs (see Fig. 20).

**4.10.6 Door Protective and Reopening Device.** Elevator doors shall open and close automatically. They shall be provided with a reopening device that will stop and reopen a car door and hoistway door automatically if the door becomes obstructed by an object or a person. The device shall be capable of completing these operations without requiring contact for an obstruction passing through the opening at heights of five (5) inches and twenty-nine (29) inches (one hundred twenty-five (125) millimeters and seven hundred thirty-five (735) millimeters) above finish floor (see Fig. 20). Door reopening devices shall remain effective for at least twenty (20) seconds. After such an interval, doors may close in accordance with the requirements of the Indiana Safety Code for Elevators, Escalators, Manlifts, and Hoists (675 IAC 21).

**4.10.7 Door and Signal Timing for Hall Calls.** The minimum acceptable time from notification that a car is answering a call until the doors of that car start to close shall be calculated from the following equation:

$$T = D/(1.5 \text{ ft/s})$$

or

$$T = D/(445 \text{ mm/s})$$

Where T equals total time in seconds and D equals distance (in feet or millimeters) from a point in the lobby or corridor sixty (60) inches (one thousand five hundred twenty-five

(1,525) millimeters) directly in front of the farthest call button controlling that car to the centerline of its hoistway door (see Fig. 21). For cars with in-car lanterns, T begins when the lantern is visible from the vicinity of hall call buttons and an audible signal is sounded. The minimum acceptable notification time shall be five (5) seconds.

**4.10.8 Door Delay for Car Calls.** The minimum time for elevator doors to remain fully open in response to a car call shall be three (3) seconds.

**4.10.9 Floor Plan for Elevator Cars.** The floor area of elevator cars shall provide space for wheelchair users to enter the car, maneuver within reach of controls, and exit from the car. Door openings and inside dimensions shall be as shown in Fig. 22. The clearance between the car platform sill and the edge of any hoistway landing shall be not greater than one and one-fourth (1¼) inches (thirty-two (32) millimeters).

**4.10.10 Floor Surfaces.** Floor surfaces shall comply with section 4.5.

**4.10.11 Illumination Levels.** The level of illumination at the car controls, platform, and car threshold and landing sill shall be at least five (5) foot-candles (fifty-three and eight-tenths (53.8) lux).

**4.10.12 Car Controls.** Elevator control panels shall have the following features:

(1) Buttons. All control buttons shall be at least three-fourths (¾) inch (nineteen (19) millimeters) in their least dimension. They shall be raised or flush.

(2) Tactile, Braille, and Visual Control Indicators. All control buttons shall be designated by braille and by raised standard alphabet characters for letter, arabic characters for numerals, or standard symbols as shown in Fig. 23(a), and as required by the Indiana Safety Code for Elevators, Escalators, Manlifts, and Hoists (675 IAC 21). Raised and braille characters and symbols shall comply with section 4.30. The call button for the main entry floor shall be designated by a raised star at the left of the floor designation (see Fig. 23(a)). All raised designations for control buttons shall be placed immediately to the left of the button to which they apply. Applied plates, permanently attached, are an acceptable means to provide raised control designations. Floor buttons shall be provided with visual indicators to show when each call is registered. The visual indicators shall be extinguished when each call is answered.

(3) Height. All floor buttons shall be no higher than fifty-four (54) inches (one thousand three hundred seventy (1,370) millimeters) above the finish floor for side approach and forty-eight (48) inches (one thousand two hundred twenty (1,220) millimeters) for front approach. Emergency controls, including the emergency alarm and emergency stop, shall be grouped at the bottom of the panel and shall have their centerlines no less than thirty-five (35) inches (eight hundred ninety (890) millimeters) above the finish floor (see Fig. 23(a) and Fig. 23(b)).

(4) Location. Controls shall be located on a front wall if cars have center opening doors, and at the side wall or at the front wall next to the door if cars have side opening doors (see Fig. 23(c) and Fig. 23(d)).

**4.10.13 Car Position Indicators.** In elevator cars, a visual position indicator shall be provided above the car control panel or over the door to show the position of the elevator in the hoistway. As the car passes or stops at a floor served by the elevators, the corresponding numerals shall illuminate, and an audible signal shall sound. Numerals shall be a minimum of one-half (½) inch (thirteen (13) millimeters) high. The audible signal shall be no less than twenty (20) decibels with a frequency no higher than one thousand five hundred (1,500) Hertz. An automatic verbal announcement of the floor number at which a car stops or which a car passes may be substituted for the audible signal.

**4.10.14 Emergency Communications.** If provided, emergency two-way communication systems between the elevator and a point outside the hoistway shall comply with the Indiana Safety Code for Elevators, Escalators, Manlifts, and Hoists (675 IAC 21). The highest operable part of a two-way communication system shall be a maximum of forty-eight (48) inches (one thousand two hundred twenty (1,220) millimeters) from the floor of the car. It shall be identified by a raised symbol and lettering complying with section 4.30 and located adjacent to the device. If the system uses a handset, then the length of the cord from the panel to the handset shall be at least twenty-nine (29) inches (seven hundred thirty-five (735) millimeters). If the system is located in a closed compartment, the compartment door hardware shall conform to section 4.27. The emergency intercommunication system shall not require voice communication.

**4.11 Platform Lifts (Wheelchair Lifts).**

**4.11.1 Location.** Platform lifts (wheelchair lifts) permitted by section 4.1 shall comply with the requirements of section 4.11.

**4.11.2 Requirements.** If platform lifts (wheelchair lifts) are used, they shall comply with sections 4.2.4, 4.5, 4.27, and 4.30, and the Indiana Safety Code for Elevators, Escalators, Manlifts, and Hoists (675 IAC 21).

**4.11.3 Entrance.** If platform lifts are used, they shall facilitate unassisted entry, operation, and exit from the lift in compliance with section 4.11.2.

**4.12 Reserved.**

**4.13 Doors.**

**4.13.1 General.** Doors required to be accessible by section 4.1 shall comply with the requirements of section 4.13.

**4.13.2 Revolving Doors and Turnstiles.** Revolving doors or turnstiles shall not be the only means of passage at an accessible entrance or along an accessible route. An accessible gate or door shall be provided adjacent to the turnstile or revolving door and shall be so designed as to facilitate the same use pattern.

**4.13.3 Gates.** Gates, including ticket gates, shall meet all applicable specifications of 4.13.

**4.13.4 Double-Leaf Doorways.** If doorways have two (2) independently operated door leaves, then at least one (1) leaf shall meet the specifications in sections 4.13.5 and 4.13.6. That leaf shall be an active leaf.

**4.13.5 Clear Width.** Doorways shall have a minimum clear opening of thirty-two (32) inches (eight hundred fifteen (815) millimeters) with the door open ninety (90) degrees, measured between the face of the door and the opposite stop (see Fig. 24(a), Fig. 24(b), Fig. 24(c), and Fig. 24(d)). Openings more than twenty-four (24) inches (six hundred ten (610) millimeters) in depth shall comply with sections 4.2.1 and 4.3.3 (see Fig. 24(e)).

**EXCEPTION:** Doors not requiring full user passage, such as shallow closets, may have the clear opening reduced to twenty (20) inches (five hundred ten (510) millimeters) minimum.

**4.13.6 Maneuvering Clearances at Doors.** Minimum maneuvering clearances at doors that are not automatic or power-assisted shall be as shown in Fig. 25. The floor or ground area within the required clearances shall be level and clear.

**EXCEPTION:** Entry doors to acute care hospital bedrooms for in-patients shall be exempted from the requirement for space at the latch side of the door (see dimension "x" in Fig. 25) if the door is at least forty-four (44) inches (one thousand one hundred twenty (1,120) millimeters) wide.

**4.13.7 Two Doors in Series.** The minimum space between two (2) hinged or pivoted doors in series shall be forty-eight (48) inches (one thousand two hundred twenty (1,220) millimeters) plus the width of any door swinging into the space. Doors in series shall swing either in the same direction or away from the space between the doors (see Fig. 26).

**4.13.8 Thresholds at Doorways.** Thresholds at doorways shall not exceed three-fourths (¾) inch (nineteen (19) millimeters) in height for exterior sliding doors or one-half (½) inch (thirteen (13) millimeters) for other types of doors. Raised thresholds and floor level changes at accessible doorways shall be beveled with a slope no greater than 1:2 (see section 4.5.2).

**4.13.9 Door Hardware.** Handles, pulls, latches, locks, and other operating devices on accessible doors shall have a shape that is easy to grasp with one (1) hand and does not require tight grasping, tight pinching, or twisting of the wrist to operate. Lever-operated mechanisms, push-type mechanisms, and u-shaped handles are acceptable designs. When sliding doors are fully open, operating hardware shall be exposed and usable from both sides. Hardware required for accessible door passage shall be mounted no higher than forty-eight (48) inches (one thousand two hundred twenty (1,220) millimeters) above finished floor.

**4.13.10 Door Closers.** If a door has a closer, then the sweep period of the closer shall be adjusted so that from an open position of seventy (70) degrees, the door will take at least three (3) seconds to move to a point three (3) inches

(seventy-five (75) millimeters) from the latch, measured to the leading edge of the door.

**4.13.11 Door Opening Force.** The maximum force for pushing or pulling open a door shall be as follows:

Interior hinged doors 5 lbf (22.2N)

Sliding or folding door 5 lbf (22.2N)

**EXCEPTION:** Door assemblies used in wall assemblies to retard the passage of fire.

These forces do not apply to the force required to retract latch bolts or disengage other devices that may hold the door in a closed position.

**4.13.12 Automatic Doors and Power-Assisted Doors.** If an automatic door is used, then it shall comply with Chapter 10 of the Indiana Building Code (675 IAC 13). Slowly opening, low powered, automatic doors shall comply with Chapter 10 of the Indiana Building Code (675 IAC 13). Such doors shall not open to back check faster than three (3) seconds and shall require no more than fifteen (15) lbf (sixty-six and six-tenths (66.6) N) to stop door movement. If a power-assisted door is used, its door-opening force shall comply with section 4.13.11 and its closing shall conform to the requirements in Chapter 10 of the Indiana Building Code (675 IAC 13).

**4.14 Entrances.**

**4.14.1 Minimum Number.** Entrances required to be accessible by section 4.1 shall be part of an accessible route complying with section 4.3. Such entrances shall be connected by an accessible route to public transportation stops, accessible parking and passenger loading zones, and public streets or sidewalks if available within the site where the Class 1 structure is located (see section 4.3.2(1)). They shall also be connected by an accessible route to all accessible spaces or elements within the building or facility.

**4.14.2 Service Entrances.** A service entrance shall not be the sole accessible entrance unless it is the only entrance to a building or facility, for example, in a factory or garage.

**4.15 Drinking Fountains and Water Coolers.**

**4.15.1 Minimum Number.** Drinking fountains or water coolers required to be accessible by section 4.1 shall comply with section 4.15.

**4.15.2 Spout Height.** Spouts shall be not higher than thirty-six (36) inches (nine hundred fifteen (915) millimeters), measured from the floor or ground surfaces to the spout outlet (see Fig. 27(a)).

**4.15.3 Spout Location.** The spouts of drinking fountains and water coolers shall be at the front of the unit and shall direct the water flow in a trajectory that is parallel or nearly parallel to the front of the unit. The spout shall provide a flow of water at least four (4) inches (one hundred (100) millimeters) high so as to allow the intersection of a cup or glass under the flow of water. On an accessible drinking fountain with a round or oval bowl, the spout must be positioned so the flow of water is within three (3) inches (seventy-five (75) millimeters) of the front edge of the fountain.

**4.15.4 Controls.** Unit controls shall be front-mounted or side-mounted near the front edge, and comply with section 4.27.4.

**4.15.5 Clearances.**

(1) Wall and post-mounted cantilevered units shall have a clear knee space between the bottom of the apron and the floor or ground at least twenty-seven (27) inches (six hundred eighty-five (685) millimeters) high, thirty (30) inches (seven hundred sixty (760) millimeters) wide, and seventeen (17) inches to nineteen (19) inches (four hundred thirty (430) millimeters) to four hundred eighty-five (485 millimeters) deep (see Fig. 27(a) and Fig. 27(b)). Such units shall also have a minimum clear floor space thirty (30) inches by forty-eight (48) inches (seven hundred sixty (760) millimeters by one thousand two hundred twenty (1,220) millimeters) to allow a person in a wheelchair to approach the unit facing forward.

(2) Free-standing or built-in units not having a clear space under them shall have a clear floor space at least thirty (30) inches by forty-eight (48) inches (seven hundred sixty (760) millimeters by one thousand two hundred twenty (1,220) millimeters) that allows a person in a wheelchair to make a parallel approach to the unit (see Fig. 27(c) and Fig. 27(d)). This clear floor space shall comply with section 4.2.4.

**4.16 Water Closets.**

**4.16.1 General.** Accessible water closets shall comply with section 4.16.

**4.16.2 Clear Floor Space.** Clear floor space for water closets not in stalls shall comply with Fig. 28. Clear floor space may be arranged to allow either a left-handed or right-handed approach.

**4.16.3 Height.** The height of water closets shall be seventeen (17) inches to nineteen (19) inches (four hundred thirty (430) millimeters to four hundred eighty-five (485) millimeters), measured to the top of the toilet seat (see Fig. 29(b)). Seats shall not be sprung to return to a lifted position.

**4.16.4 Grab Bars.** Grab bars for water closets not located in stalls shall comply with section 4.26 and Fig. 29. The grab bar behind the water closet shall be thirty-six (36) inches (nine hundred fifteen (915) millimeters) minimum.

**4.16.5 Flush Controls.** Flush controls shall be hand-operated or automatic and shall comply with section 4.27.4. Controls for flush valves shall be mounted on the wide side of toilet areas no more than forty-four (44) inches (one thousand one hundred twenty (1,120) millimeters) above the floor.

**4.17 Toilet Stalls.**

**4.17.1 Location.** Accessible toilet stalls shall be on an accessible route and shall meet the requirements of section 4.17.

**4.17.2 Water closets.** Water closets in accessible stalls shall comply with section 4.16.

**4.17.3 Size and Arrangement.** The size and arrangement of the standard toilet stall shall comply with Fig. 30(a),

**Standard Stall.** Standard toilet stalls with a minimum depth of fifty-six (56) inches (one thousand four hundred twenty (1,420) millimeters) (see Fig. 30(a)) shall have wall-mounted water closets. If the depth of a standard toilet stall is increased at least three (3) inches (seventy-five (75) millimeters), then a floor-mounted water closet may be used. Arrangements shown for standard toilet stalls may be reversed to allow either a left-hand or right-hand approach. Additional stalls shall be provided in conformance with section 4.22.4.

**4.17.4 Toe Clearances.** In standard stalls, the front partition and at least one (1) side partition shall provide a toe clearance of at least nine (9) inches (two hundred thirty (230) millimeters) above the floor. If the depth of the stall is greater than sixty (60) inches (one thousand five hundred twenty-five (1,525) millimeters), then the toe clearance is not required.

**4.17.5 Doors.** Toilet stall doors, including door hardware, shall comply with section 4.13. If the toilet stall approach is from the latch side of the stall door, clearance between the door side of the stall and any obstruction may be reduced to a minimum of forty-two (42) inches (one thousand sixty-five (1,065) millimeters) (Fig. 30).

**4.17.6 Grab Bars.** Grab bars complying with the length and positioning shown in Fig. 30(a), Fig. 30(d), and Fig. 30(c) shall be provided. Grab bars may be mounted with any desired method as long as they have a gripping surface at the locations shown and do not obstruct the required clear floor area. Grab bars shall comply with section 4.26.

**4.18 Urinals.**

**4.18.1 General.** Accessible urinals shall comply with section 4.18.

**4.18.2 Height.** Urinals shall be stall-type or wall-hung with an elongated rim at a maximum of seventeen (17) inches (four hundred thirty (430) millimeters) above the finish floor.

**4.18.3 Clear Floor Space.** A clear floor space thirty (30) inches by forty-eight (48) inches (seven hundred sixty (760) millimeters by one thousand two hundred twenty (1,220) millimeters) shall be provided in front of urinals to allow forward approach. This clear space shall adjoin or overlap an accessible route and shall comply with section 4.2.4. Urinal shields that do not extend beyond the front edge of the urinal rim may be provided with twenty-nine (29) inches (seven hundred thirty-five (735) millimeters) clearance between them.

**4.18.4 Flush Controls.** Flush controls shall be hand-operated or automatic, and comply with section 4.27.4 and be mounted no more than forty-four (44) inches (one thousand one hundred twenty (1,120) millimeters) above the finish floor.

**4.19 Lavatories and Mirrors.**

**4.19.1 General.** The requirements of section 4.19 shall apply to lavatory fixtures, vanities, mirrors, and built-in lavatories.

**4.19.2 Height and Clearances.** Lavatories shall be mounted

with the rim or counter surface no higher than thirty-four (34) inches (eight hundred sixty-five (865) millimeters) above the finish floor and provide a clearance of at least twenty-nine (29) inches (seven hundred thirty-five (735) millimeters) above the finish floor to the bottom of the apron. Knee and toe clearance shall comply with Fig. 31.

**4.19.3 Clear Floor Space.** A clear floor space thirty (30) inches by forty-eight (48) inches (seven hundred sixty (760) millimeters by one thousand two hundred twenty (1,220) millimeters) complying with section 4.2.4 shall be provided in front of a lavatory to allow forward approach. Such clear floor space shall adjoin or overlap an accessible route and shall extend a maximum of nineteen (19) inches (four hundred eighty-five (485) millimeters) underneath the lavatory (see Fig. 32).

**4.19.4 Exposed Pipes and Surfaces.** Hot water and drain pipes under lavatories shall be insulated or otherwise configured to protect against contact. There shall be no sharp or abrasive surfaces under lavatories.

**4.19.5 Faucets.** Faucets shall comply with section 4.27.4. Lever-operated, push-type, and electronically controlled mechanisms are examples of acceptable designs. If self-closing valves are used the faucet shall remain open for at least ten (10) seconds.

**4.19.6 Mirrors.** Mirrors shall be mounted with the bottom edge of the reflecting surface no higher than forty (40) inches (one thousand fifteen (1,015) millimeters) above the finish floor (see Fig. 31).

**4.20 Bathtubs.**

**4.20.1 General.** Accessible bathtubs shall comply with section 4.20.

**4.20.2 Floor Space.** Clear floor space in front of bathtubs shall be as shown in Fig. 33.

**4.20.3 Seat.** An in-tub seat or a seat at the head end of the tub shall be provided as shown in Fig. 33 and Fig. 34. The structural strength of seats and their attachments shall comply with section 4.26.3. Seats shall be mounted securely and shall not slip during use.

**4.20.4 Grab Bars.** Grab bars complying with section 4.26 shall be provided as shown in Fig. 33 and Fig. 34.

**4.20.5 Controls.** Faucets and other controls complying with section 4.27.4 shall be located as shown in Fig. 34.

**4.20.6 Shower Unit.** A shower spray unit with a hose at least sixty (60) inches (one thousand five hundred twenty-five (1,525) millimeters) long that can be used both as a fixed shower head and as a hand-held shower shall be provided.

**4.20.7 Bathtub Enclosures.** If provided, enclosures for bathtubs shall not obstruct controls or transfer from wheelchairs onto bathtub seats or into tubs. Enclosures on bathtubs shall not have tracks mounted on their rims.

**4.21 Shower Stalls.**

**4.21.1 General.** Accessible shower stalls shall comply with section 4.21.

**4.21.2 Size and Clearance.** Except as specified in section 9.1.2, shower stall size and clear floor space shall comply

---

## Proposed Rules

---

with Fig. 35(a) or 35(b). The shower stall in Fig. 35(a) shall be thirty-six (36) inches by thirty-six (36) inches (nine hundred fifteen (915) millimeters by nine hundred fifteen (915) millimeters). Shower stalls required by section 9.1.2 shall comply with Fig. 57(a) or 57(b). The shower stall in Fig. 35(b) will fit into the space required for a bathtub.

**4.21.3 Seat.** A seat shall be provided in shower stalls thirty-six (36) inches by thirty-six (36) inches (nine hundred fifteen (915) millimeters by nine hundred fifteen (915) millimeters) and shall be as shown in Fig. 36. The seat shall be mounted seventeen (17) inches to nineteen (19) inches (four hundred thirty (430) millimeters to four hundred eighty-five (485) millimeters) from the bathroom floor and shall extend the full depth of the stall. In a thirty-six (36) inch by thirty-six (36) inch (nine hundred fifteen (915) millimeters by nine hundred fifteen (915) millimeters) shower stall, the seat shall be on the wall opposite the controls. Where a fixed seat is provided in a thirty (30) inch by sixty (60) inch minimum (seven hundred sixty (760) millimeters by one thousand five hundred twenty-five (1,525) millimeters) shower stall, it shall be a folding type and shall be mounted on the wall adjacent to the controls as show in Fig. 57. The structural strength of seats and their attachments shall comply with section 4.26.3.

**4.21.4 Grab Bars.** Grab bars complying with section 4.26 shall be provided as shown in Fig. 37.

**4.21.5 Controls.** Faucets and other controls complying with section 4.27.4 shall be located as shown in Fig. 37. In shower stalls thirty-six (36) inches by thirty-six (36) inches (nine hundred fifteen (915) millimeters by nine hundred fifteen (915) millimeters), all controls, faucets, and the shower unit shall be mounted on the side wall opposite the seat.

**4.21.6 Shower Unit.** A shower spray unit with a hose at least sixty (60) inches (one thousand five hundred twenty-five (1,525) millimeters) long that can be used both as a fixed shower head and as a hand-held shower shall be provided.

**EXCEPTION:** In unmonitored facilities where vandalism is a consideration, a fixed shower head mounted at forty-eight (48) inches (one thousand two hundred twenty (1,220) millimeters) above the shower floor may be used in lieu of a hand-held shower head.

**4.21.7 Curbs.** If provided, curbs in shower stalls thirty-six (36) inches by thirty-six (36) inches (nine hundred fifteen (915) millimeters by nine hundred fifteen (915) millimeters) shall be no higher than one-half ( $\frac{1}{2}$ ) inch (thirteen (13) millimeters). Shower stalls that are thirty (30) inches by sixty (60) inches (seven hundred sixty (760) millimeters by one thousand five hundred twenty-five (1,525) millimeters) minimum shall not have curbs.

**4.21.8 Shower Enclosures.** If provided, enclosures for shower stalls shall not obstruct controls or transfer from wheelchairs onto shower seats.

### 4.22 Toilet Rooms.

**4.22.1 Minimum Number.** Toilet facilities required to be accessible by section 4.1 shall comply with section 4.22.

Accessible toilet rooms shall be on an accessible route.

**4.22.2 Doors.** All doors to accessible toilet rooms shall comply with section 4.13. Doors shall not swing into the clear floor space required for any fixture.

**4.22.3 Clear Floor Space.** The accessible fixtures and controls required in sections 4.22.4, 4.22.5, 4.22.6, and 4.22.7 shall be on an accessible route. An unobstructed turning space complying with section 4.2.3 shall be provided within an accessible toilet room. The clear floor space at fixtures and controls, the accessible route, and the turning space may overlap.

**4.22.4 Water Closets.** If toilet stalls are provided, then at least one (1) shall be a standard toilet stall complying with section 4.17; where six (6) or more stalls are provided, in addition to the stall complying with section 4.17.3, at least one (1) stall thirty-six (36) inches (nine hundred fifteen (915) millimeters) wide with an outward swinging, self-closing door and parallel grab bars complying with Fig. 30(d) and section 4.26 shall be provided. Water closets in such stalls shall comply with section 4.16. If water closets are not in stalls, then at least one (1) shall comply with section 4.16.

**4.22.5 Urinals.** If urinals are provided, then at least one (1) shall comply with section 4.18.

**4.22.6 Lavatories and Mirrors.** If lavatories and mirrors are provided, then at least one (1) shall comply with section 4.19.

**4.22.7 Controls and Dispensers.** If controls, dispensers, receptacles, or other equipment are provided, then at least one (1) of each shall be on an accessible route and shall comply with section 4.27.

### 4.23 Bathrooms, Bathing Facilities, and Shower Rooms.

**4.23.1 Minimum Number.** Bathrooms, bathing facilities, or shower rooms required to be accessible by section 4.1 shall comply with section 4.23 and shall be on an accessible route.

**4.23.2 Doors.** Doors to accessible bathrooms shall comply with section 4.13. Doors shall not swing into the floor space required for any fixture.

**4.23.3 Clear Floor Space.** The accessible fixtures required in sections 4.23.4, 4.23.5, 4.23.6, 4.23.7, 4.23.8, and 4.23.9 shall be on an accessible route. An unobstructed turning space complying with section 4.2.3 shall be provided within an accessible bathroom. The clear floor spaces at fixtures and controls, the accessible route, and the turning space may overlap.

**4.23.4 Water Closets.** If toilet stalls are provided, then at least one (1) shall be a standard toilet stall complying with section 4.17; where six (6) or more stalls are provided, in addition to the stall complying with section 4.17.3, at least one (1) stall thirty-six inches (nine hundred fifteen (915) millimeters) wide with an outward swinging, self-closing door and parallel grab bars complying with Fig. 30(d) and section 4.26 shall be provided. Water closets in such stalls shall comply with section 4.16. If water closets are not in stalls, then at least one (1) shall comply with section 4.16.

**4.23.5 Urinals.** If urinals are provided, then at least one (1) shall comply with section 4.18.

**4.23.6 Lavatories.** If lavatories are provided, then at least one (1) shall comply with section 4.19.

**4.23.7 Controls and dispensers.** If controls, dispensers, receptacles, or other equipment are provided, then at least one (1) of each shall be on an accessible route and shall comply with section 4.27.

**4.23.8 Bathing and Shower Facilities.** If tubs or showers are provided, then at least one (1) accessible tub that complies with section 4.20 or at least one (1) accessible shower that complies with 4.21 shall be provided.

**4.23.9 Medicine Cabinets.** If medicine cabinets are provided, at least one (1) shall be located with a usable shelf no higher than forty-four (44) inches (one thousand one hundred twenty (1,120) millimeters) above the floor space. The floor space shall comply with 4.2.4.

**4.24 Sinks.**

**4.24.1 General.** Sinks required to be accessible by section 4.1 shall comply with section 4.24.

**4.24.2 Height.** Sinks shall be mounted with the counter or rim no higher than thirty-four (34) inches (eight hundred sixty-five (865) millimeters) above the finish floor.

**4.24.3 Knee Clearance.** Knee clearance that is at least twenty-seven (27) inches (six hundred eighty-five (685) millimeters) high, thirty (30) inches (seven hundred sixty (760) millimeters) wide, and nineteen (19) inches (four hundred eighty-five (485) millimeters) deep shall be provided underneath sinks.

**4.24.4 Depth.** Each sink shall be a maximum of six and one-half (6½) inches (one hundred sixty-five (165) millimeters) deep.

**4.24.5 Clear Floor Space.** A clear floor space at least thirty (30) inches by forty-eight (48) inches (seven hundred sixty (760) millimeters by one thousand two hundred twenty (1,220) millimeters) complying with section 4.2.4 shall be provided in front of a sink to allow forward approach. The clear floor space shall be on an accessible route and shall extend a maximum of nineteen (19) inches (four hundred eighty-five (485) millimeters) underneath the sink (see Fig. 32).

**4.24.6 Exposed Pipes and Surfaces.** Hot water and drain pipes exposed under sinks shall be insulated or otherwise configured so as to protect against contact. There shall be no sharp or abrasive surfaces under sinks.

**4.24.7 Faucets.** Faucets shall comply with section 4.27.4. Lever-operated, push-type, touch-type, or electronically controlled mechanisms are acceptable designs.

**4.25 Storage.**

**4.25.1 General.** Fixed storage facilities such as cabinets, shelves, closets, and drawers required to be accessible by section 4.1 shall comply with section 4.25.

**4.25.2 Clear Floor Space.** A clear floor space at least thirty (30) inches by forty-eight (48) inches (seven hundred sixty (760) millimeters by one thousand two hundred twenty (1,220) millimeters) complying with section 4.2.4 that allows either a forward or parallel approach by a person using a

wheelchair shall be provided at accessible storage facilities.

**4.25.3 Height.** Accessible storage spaces shall be within at least one (1) of the reach ranges specified in sections 4.2.5 and 4.2.6 (see Fig. 5 and Fig. 6). Clothes rod shelves shall be a maximum of fifty-four (54) inches (one thousand three hundred seventy (1,370) millimeters) above the finish floor for a side approach. Where the distance from the wheelchair to the clothes rod or shelf exceeds ten (10) inches (two hundred fifty-five (255) millimeters) (as in closets without accessible doors) the height and depth to the rod or shelf shall comply with Fig. 38(a) and Fig. 38(b).

**4.25.4 Hardware.** Hardware for accessible storage facilities shall comply with section 4.27.4. Touch latches and U-shaped pulls are acceptable.

**4.26 Handrails, Grab Bars, and Tub and Shower Seats.**

**4.26.1 General.** All handrails, grab bars, and tub and shower seats required to be accessible by 4.1, 4.8, 4.9, 4.16, 4.17, 4.20, or 4.21 shall comply with section 4.26.

**4.26.2 Size and Spacing of Grab Bars and Handrails.** The diameter or width of the gripping surfaces of a handrail or grab bar shall be one and one-fourth (1¼) inches to one and one-half (1½) inches (thirty-two (32) millimeters to thirty-eight (38) millimeters), or the shape shall provide an equivalent gripping surface. If handrails or grab bars are mounted adjacent to a wall, the space between the wall and the grab bar shall be one and one-half (1½) inches (thirty-eight (38) millimeters) (see Fig. 39(a), Fig. 39(b), Fig. 39(c), and Fig. 39(e)). Handrails may be located in a recess if the recess is a maximum of three (3) inches (seventy-five (75) millimeters) deep and extends at least eighteen (18) inches (four hundred fifty-five (455) millimeters) above the top of the rail (see Fig. 39(d)).

**4.26.3 Structural Strength.** The structural strength of grab bars, tub and shower seats, fasteners, and mounting devices shall meet the following specifications:

(1) Bending stress in a grab bar or seat induced by the maximum bending moment from the application of two hundred fifty (250) lbf (one thousand one hundred twelve (1,112) N) shall be less than the allowable stress for the material of the grab bar or seat.

(2) Shear stress induced in a grab bar or seat by the application of two hundred fifty (250) lbf (one thousand one hundred twelve (1,112) N) shall be less than the allowable shear stress for the material of the grab bar or seat. If the connection between the grab bar or seat and its mounting bracket or other support is considered to be fully restrained, then direct and torsional shear stress shall be totaled for the combined shear stress, which shall not exceed the allowable shear stress.

(3) Shear forced induced in a fastener or mounting device from the application of two hundred fifty (250) lbf (one thousand one hundred twelve (1,112) N) shall be less than the allowable lateral load of either the fastener or mounting device or the supporting structure, whichever is the smaller allowable load.

---

---

## Proposed Rules

---

---

(4) Tensile force induced in a fastener by a direct tension force of two hundred fifty (250) lbf (one thousand one hundred twelve (1,112) N) plus the maximum moment from the application of two hundred fifty (250) lbf (one thousand one hundred twelve (1,112) N) shall be less than the allowable withdrawal load between the fastener and the supporting structure.

(5) Grab bars shall not rotate within their fittings.

**4.26.4 Eliminating Hazards.** A handrail or grab bar and any wall or other surface adjacent to it shall be free of any sharp or abrasive elements. Edges shall have a minimum radius of one-eighth ( $\frac{1}{8}$ ) inch (three and two-tenths (3.2) millimeters).

**4.27 Controls and Operating Mechanisms.**

**4.27.1 General.** Controls and operating mechanisms required to be accessible by section 4.1 shall comply with section 4.27.

**4.27.2 Clear Floor Space.** Clear floor space complying with section 4.2.4 that allows a forward or a parallel approach by a person using a wheelchair shall be provided at controls, dispensers, receptacles, and other operable equipment.

**4.27.3 Height.** The highest operable part of controls, dispensers, receptacles, and other operable equipment shall be placed within at least one (1) of the reach ranges specified in sections 4.2.5 and 4.2.6. Electrical and communications system receptacles on walls shall be mounted no less than fifteen (15) inches (three hundred eighty (380) millimeters) above the floor.

**EXCEPTION:** These requirements do not apply where the use of special equipment dictates otherwise or where electrical and communications systems receptacles are not normally intended for use by building occupants.

**4.27.4 Operation.** Controls and operating mechanisms shall be operable with one (1) hand and shall not require tight grasping, pinching, or twisting of the wrist. The force required to activate controls shall be no greater than five (5) lbf (twenty-two and two-tenths (22.2) N).

**4.28 Alarms.**

**4.28.1 General.** Alarm systems, if provided, that are required to be accessible by section 4.1 shall comply with section 4.28. At a minimum, visual signal appliances shall be provided in buildings and facilities in each of the following areas:

- (1) Rest rooms.
- (2) Any other general usage areas, such as:
  - (A) meeting rooms;
  - (B) hallways;
  - (C) lobbies; and
  - (D) any other area for common use.

**4.28.2 Audible Alarms.** If provided, audible emergency alarms shall produce a sound that exceeds the prevailing equivalent sound level in the room or space by at least fifteen (15) dbA or exceeds any maximum sound level with a duration of sixty (60) seconds by five (5) dbA, whichever is louder. Sound levels for alarm signals shall not exceed one hundred twenty (120) dbA.

**4.28.3 Visual Alarms.** Visual alarm signal appliances shall be integrated into the building or facility alarm system. If single station audible alarms are provided, then single station visual alarm signals shall be provided. Visual alarm signals shall have the following minimum photometric and location features:

- (1) The lamp shall be a xenon strobe type or equivalent.
- (2) The color shall be clear or nominal white (i.e., unfiltered or clear filtered white light).
- (3) The maximum pulse duration shall be two-tenths (0.2) of one (1) second with a maximum duty cycle of forty percent (40%). The pulse duration is defined as the time interval between initial and final points of ten percent (10%) of maximum signal.
- (4) The intensity shall be a minimum of seventy-five (75) candela.
- (5) The flash rate shall be a minimum of one (1) hertz and maximum of three (3) hertz.
- (6) The appliance shall be placed eighty (80) inches (two thousand thirty (2,030) millimeters) above the highest floor level within the space or six (6) inches (one hundred fifty-two (152) millimeters) below the ceiling, whichever is lower.
- (7) In general, no place in any room or space required to have a visual signal appliance shall be more than fifty (50) feet (fifteen (15) meters) from the signal (in the horizontal plane). In large rooms and spaces exceeding one hundred (100) feet (thirty (30) meters) across, without obstructions six (6) feet (two (2) meters) above the finish floor, such as auditoriums, devices may be placed around the perimeter, spaced a maximum one hundred (100) feet (thirty (30) meters) apart, in lieu of suspending appliances from the ceiling.
- (8) No place in common corridors or hallways in which visual alarm signaling appliances are required shall be more than fifty (50) feet (fifteen (15) meters) from the signal.

**4.28.4 Auxiliary Alarms.** Dwelling units and sleeping accommodations shall have a visual alarm connected to the building emergency alarm system or shall have a standard one hundred ten (110) volt electrical receptacle into which such an alarm can be connected and a means by which a signal from the building emergency alarm system can trigger such an auxiliary alarm. When visual alarms are in place, the signal shall be visible in all areas of the unit or room. Instructions for use of the auxiliary alarm or receptacle shall be provided.

**4.29 Reserved.**

**4.30 Signage.**

**4.30.1 General.** Signage required to be accessible by section 4.1 shall comply with the applicable provisions of section 4.30.

**4.30.2 Character Proportion.** Letters and numbers on signs shall have a width-to-height ratio between 3:5 and 1:1 and a stroke-width-to-height ratio between 1:5 and 1:10.

**4.30.3 Character Height.** Characters and numbers on signs



shall be sized according to the viewing distance from which they are to be read. The minimum height is measured using an uppercase X. Lowercase characters are permitted.

Height Above Finished Floor	Minimum Character Height
Suspended or projected overhead in compliance with section 4.4.2	3 in. (75 mm) minimum

**4.30.4 Raised and Brailled Characters and Pictorial Symbol Signs (Pictograms).** Letters and numerals shall be raised one thirty-second ( $1/32$ ) inch, uppercase, sans serif, or simple serif type and shall be accompanied with Grade 2 braille. Raised characters shall be at least five-eighths ( $5/8$ ) inch (sixteen (16) millimeters) high, but no higher than two (2) inches (fifty (50) millimeters). Pictograms shall be accompanied by the equivalent verbal description placed directly below the pictogram. The border dimension of the pictogram shall be six (6) inches (one hundred fifty-two (152) millimeters) minimum in height.

**4.30.5 Finish and Contrast.** The characters and background of signs shall be eggshell, matte, or other nonglare finish. Characters and symbols shall contrast with their background, either light characters on a dark background or dark characters on a light background.

**4.30.6 Mounting Location and Height.** Where permanent identification is provided for rooms and spaces, signs shall be installed on the wall adjacent to the latch side of the door. Where there is no wall space to the latch side of the door, including at double leaf doors, signs shall be placed on the nearest adjacent wall. Mounting height shall be sixty (60) inches (one thousand five hundred twenty-five (1,525) millimeters) above the finish floor to the centerline of the sign. Mounting location for such signage shall be so that a person may approach within three (3) inches (seventy-six (76) millimeters) of signage without encountering protruding objects or standing within the swing of a door.

**4.30.7 Symbols of Accessibility.**

(1) Facilities and elements required to be identified as accessible by section 4.1 shall use the international symbol of accessibility. The symbol shall be displayed as shown in Fig. 43(a) and Fig. 43(b).

(2) **Volume Control Telephones.** Telephones required to have a volume control by 4.1.3(17)(b) shall be identified by a sign containing a depiction of a telephone handset with radiating sound waves.

(3) **Text Telephones.** Text telephones required by section 4.1.3(17)(c) shall be identified by the international TDD symbol (Fig 43(c)). In addition, if a facility has a public text telephone, directional signage indicating the location of the nearest text telephone shall be placed adjacent to all banks of telephones which do not contain a text telephone. Such directional signage shall include the international TDD symbol. If a facility has no banks of telephones, the directional signage shall be provided at the entrance (e.g., in a building directory).

(4) **Assistive Listening Systems.** In assembly areas where permanently installed assistive listening systems are required by section 4.1.3(19)(b), the availability of such systems shall be identified with signage that includes the international symbol of access for hearing loss (Fig. 43(d)).

4.30.8 Reserved.

4.31 Telephones.

4.31.1 **General.** Public telephones required to be accessible by section 4.1 shall comply with section 4.31.

4.31.2 **Clear Floor or Ground Space.** A clear floor or ground space at least thirty (30) inches by forty-eight (48) inches (seven hundred sixty (760) millimeters by one thousand two hundred twenty (1,220) millimeters) that allows either a forward or parallel approach by a person using a wheelchair shall be provided at telephones (see Fig. 44). The clear floor or ground space shall comply with section 4.2.4. Bases, enclosures, and fixed seats shall not impede approaches to telephones by people who use wheelchairs.

4.31.3 **Mounting Height.** The highest operable part of the telephone shall be within the reach ranges specified in section 4.2.5 or 4.2.6.

4.31.4 **Protruding Objects.** Telephones shall comply with section 4.4.

4.31.5 **Hearing Aid Compatible and Volume Control Telephones Required by 4.1.**

(1) Telephones shall be hearing aid compatible.

(2) Volume controls, capable of a minimum of twelve (12) dbA and a maximum of eighteen (18) dbA above normal shall be provided in accordance with 4.1.3. If an automatic reset is provided then eighteen (18) dbA may be exceeded.

4.31.6 **Controls.** Telephones shall have pushbutton controls where service for such equipment is available.

4.31.7 **Telephone Books.** Telephone books, if provided, shall be located in a position that complies with the reach ranges specified in sections 4.2.5 and 4.2.6.

4.31.8 **Cord Length.** The cord from the telephone to the handset shall be at least twenty-nine (29) inches (seven hundred and thirty-five (735) millimeters) long.

4.31.9 **Text Telephones Required by section 4.1.**

(1) Text telephones used with a pay telephone shall be permanently affixed within, or adjacent to, the telephone enclosure. If an acoustic coupler is used, the telephone cord shall be sufficiently long to allow connection of the text telephone and the telephone receiver.

(2) Pay telephones designed to accommodate a portable text telephone shall be equipped with a shelf and an electrical outlet within or adjacent to the telephone enclosure. The telephone handset shall be capable of being placed flush on the surface of the shelf. The shelf shall be capable of accommodating a text telephone and shall have six (6) inches (one hundred fifty-two (152) millimeters) minimum vertical clearance in the area where the text telephone is to be placed.

(3) Equivalent facilitation may be provided. For example, a portable text telephone may be made available in a hotel at the registration desk if it is available on a twenty-four (24) hour basis for use with nearby public pay telephones. In this instance, at least one (1) pay telephone shall comply with paragraph 2 of this section. In addition, if an acoustic coupler is used, the telephone handset cord shall be sufficiently long so as to allow connection of the text telephone and the telephone receiver. Directional signage shall be provided and shall comply with section 4.30.7.

### 4.32 Fixed or Built-in Seating and Tables.

4.32.1 Minimum Number. Fixed or built-in seating or tables required to be accessible by section 4.1 shall comply with section 4.32.

4.32.2 Seating. If seating spaces for people in wheelchairs are provided at fixed tables or counters, clear floor space complying with section 4.2.4 shall be provided. Such clear floor space shall not overlap knee space by more than nineteen (19) inches (four hundred eighty-five (485) millimeters) (see Fig. 45).

4.32.3 Knee Clearances. If seating for people in wheelchairs is provided at tables or counters, knee spaces at least twenty-seven (27) inches (six hundred eighty-five (685) millimeters) high, thirty (30) inches (seven hundred sixty (760) millimeters) wide, and nineteen (19) inches (four hundred eighty-five (485) millimeters) deep shall be provided (see Fig. 45).

4.32.4 Height of Tables or Counters. The tops of accessible tables and counters shall be from twenty-eight (28) inches to thirty-four (34) inches (seven hundred ten (710) millimeters to eight hundred sixty-five (865) millimeters) above the finish floor or ground.

### 4.33 Assembly Areas.

4.33.1 Minimum Number. Assembly and associated areas required to be accessible by section 4.1 shall comply with section 4.33.

4.33.2 Size of Wheelchair Locations. Each wheelchair location shall provide minimum clear ground or floor spaces as shown in Fig. 46.

4.33.3 Placement of Wheelchair Locations. Wheelchair areas shall be an integral part of any fixed seating plan and shall be provided so as to provide people with physical disabilities a choice of admission prices and lines of sight comparable to those for members of the general public. They shall adjoin an accessible route that also serves as a means of egress in case of emergency. At least one (1) companion fixed seat shall be provided next to each wheelchair seating area. When the seating capacity exceeds three hundred (300), wheelchair spaces shall be provided in more than one (1) location. Readily removable seats may be installed in wheelchair spaces when the spaces are not required to accommodate wheelchair users.

**EXCEPTION:** Accessible viewing positions may be clustered for bleachers, balconies, and other areas having

sight lines that require slopes of greater than five percent (5%). Equivalent accessible viewing positions may be located on levels having accessible egress.

4.33.4 Surfaces. The ground or floor at wheelchair locations shall be level and shall comply with section 4.5.

4.33.5 Access to Performing Areas. An accessible route shall connect wheelchair seating and locations with performing areas, including stages, arena floors, dressing rooms, locker rooms, and other spaces used by performers.

4.33.6 Placement of Listening Systems. If the listening system provided serves individual fixed seats, then such seats shall be located within a fifty (50) foot (fifteen (15) meters) viewing distance of the stage or playing area and shall have a complete view of the stage or playing area.

4.33.7 Types of Listening Systems. Assistive listening systems (ALS) are intended to augment standard public address and audio systems by providing signals which can be received directly by persons with special receivers or their own hearing aids and which eliminate or filter background noise. The type of assistive listening system appropriate for a particular application depends on the characteristics of the setting, the nature of the program, and the intended audience. Magnetic induction loops, infrared, and radio frequency systems are types of listening systems which are appropriate for various applications.

### 4.34 Automated Teller Machines.

4.34.1 General. Each machine required to be accessible by section 4.1.3 shall be on an accessible route and shall comply with section 4.34.

4.34.2 Controls. Controls for user activation shall comply with the requirements of section 4.27.

4.34.3 Clearances and Reach Range. Free standing or built-in units not having a clear space under them shall comply with sections 4.27.2 and 4.27.3 and provide for a parallel approach and both a forward and side reach to the unit allowing a person in a wheelchair to access the controls and dispensers.

4.34.4 Equipment for Persons with Vision Impairments. Instructions and all information for use shall be made accessible to and independently usable by persons with vision impairments.

### 4.35 Dressing and Fitting Rooms.

4.35.1 General. Dressing and fitting rooms required to be accessible by section 4.1 shall comply with section 4.35 and shall be on an accessible route.

4.35.2 Clear Floor Space. A clear floor space allowing a person using a wheelchair to make a one hundred eighty (180) degree turn shall be provided in every accessible dressing room entered through a swinging or sliding door. No door shall swing into any part of the turning space. Turning space shall not be required in a private dressing room entered through a curtained opening at least thirty-two (32) inches (eight hundred fifteen (815) millimeters) wide if clear floor space complying with section 4.2 renders the dressing room usable by a person using a wheelchair.

**4.35.3 Doors.** All doors to accessible dressing rooms shall be in compliance with section 4.13.

**4.35.4 Bench.** Every accessible dressing room shall have a twenty-four (24) inch by forty-eight (48) inch (six hundred ten (610) millimeters) by one thousand two hundred twenty (1,220) millimeters) bench fixed to the wall along the longer dimension. The bench shall be mounted seventeen (17) inches to nineteen (19) inches (four hundred thirty (430) millimeters to four hundred eighty-five (485) millimeters) above the finish floor. Clear floor space shall be provided alongside the bench to allow a person using a wheelchair to make a parallel transfer onto the bench. The structural strength of the bench and attachments shall comply with section 4.26.3. Where installed in conjunction with showers, swimming pools, or other wet locations, water shall not accumulate upon the surface of the bench and the bench shall have a slip-resistant surface.

**4.35.5 Mirror.** Where mirrors are provided in dressing rooms of the same use, then in an accessible dressing room, a full-length mirror, measuring at least eighteen (18) inches wide by fifty-four (54) inches high (four hundred sixty (460) millimeters by one thousand three hundred seventy (1,370) millimeters) shall be mounted in a position affording a view to a person on the bench as well as to a person in a standing position.

#### **5.0 Restaurants and Cafeterias.**

**5.1 General.** Except as specified or modified in this section, restaurants and cafeterias shall comply with the requirements of sections 4.1 to 4.35. Where fixed tables (or dining counters where food is consumed but there is no service) are provided, at least five percent (5%), but not less than one (1), of the fixed tables (or a portion of the dining counter) shall be accessible and shall comply with section 4.32 as required in section 4.1.3(18). In establishments where separate areas are designated for smoking and non-smoking patrons, the required number of accessible fixed tables (or counters) shall be proportionally distributed between the smoking and non-smoking areas. Accessible fixed tables (or counters) shall be distributed throughout the space or facility.

**5.2 Counters and Bars.** Where food or drink is served at counters exceeding thirty-four (34) inches (eight hundred sixty-five (865) millimeters) in height for consumption by customers seated on stools or standing at the counter, a portion of the main counter which is sixty (60) inches (one thousand five hundred twenty-five (1,525) millimeters) in length minimum shall be provided in compliance with section 4.32 or service shall be available at accessible tables within the same area.

**5.3 Access Aisles.** All accessible fixed tables shall be accessible by means of an access aisle at least thirty-six (36) inches (nine hundred fifteen (915) millimeters) clear between parallel edges of tables or between a wall and the table edges.

**5.4 Dining Areas.** All dining areas, including raised or

sunken dining areas, loggias, and outdoor seating areas, shall be accessible. In nonelevator buildings, an accessible means of vertical access to the mezzanine is not required under the following conditions:

- (1) The area of mezzanine seating measures no more than thirty-three percent (33%) of the area of the total accessible seating area.
- (2) The same services and decor are provided in an accessible space usable by the general public.
- (3) The accessible areas are not restricted to use by people with disabilities.

**5.5 Food Service Lines.** Food service lines shall have a minimum clear width of thirty-six (36) inches (nine hundred fifteen (915) millimeters), with a preferred clear width of forty-two (42) inches (one thousand sixty-five (1,065) millimeters) to allow passage around a person using a wheelchair. Tray slides shall be mounted no higher than thirty-four (34) inches (eight hundred sixty-five (865) millimeters) above the floor (see Fig. 53). If self-service shelves are provided, at least fifty percent (50%) of each type must be within reach ranges specified in sections 4.2.5 and 4.2.6.

**5.6 Tableware and Condiment Areas.** Self-service shelves and dispensing devices for tableware, dishware, condiments, food, and beverages shall be installed to comply with section 4.2 (see Fig. 54).

**5.7 Raised Platforms.** In banquet rooms or spaces where a head table or speaker's lectern is located on a raised platform, the platform shall be accessible in compliance with section 4.8 or 4.11. Open edges of a raised platform shall be protected by placement of tables or by a curb.

**5.8 Vending Machines and Other Equipment.** Spaces for vending machines and other equipment shall comply with section 4.2 and shall be located on an accessible route.

**5.9 Reserved.**

#### **6.0 Medical Care Facilities.**

**6.1 General.** Medical care facilities included in this section are those in which people receive physical or medical treatment or care and where persons may need assistance in responding to an emergency and where the period of stay may exceed twenty-four (24) hours. In addition to the requirements of sections 4.1 through 4.35, medical care facilities and buildings shall comply with section 6.0.

- (1) **Hospitals: General Purpose Hospitals, Psychiatric Facilities, Detoxification Facilities.** At least ten percent (10%) of patient bedrooms and toilets and all public use and common use areas are required to be designed and constructed to be accessible.
- (2) **Hospitals and Rehabilitation Facilities that Specialize in Treating Conditions that Affect Mobility, or Units Within Either that Specialize in Treating Conditions that Affect Mobility.** All patient bedrooms and toilets and all public use and common use areas are required to be designed and constructed to be accessible.
- (3) **Long Term Care Facilities, Nursing Homes.** At least

## Proposed Rules

fifty percent (50%) of patient bedrooms and toilets and all public use and common use areas are required to be designed and constructed to be accessible.

(4) Reserved.

**6.2 Entrances.** At least one (1) accessible entrance that complies with section 4.14 shall be protected from the weather by canopy or roof overhang. Such entrances shall incorporate a passenger loading zone that complies with section 4.6.6.

**6.3 Patient Bedrooms.** Provide accessible patient bedrooms in compliance with sections 4.1 through 4.35. Accessible patient bedrooms shall comply with the following:

(1) Each bedroom shall have a door that complies with section 4.13.

**EXCEPTION:** Entry doors to acute care hospital bedrooms for in-patients shall be exempted from the requirement in section 4.13.6 for maneuvering space at the latch side of the door if the door is at least forty-four (44) inches (one thousand one hundred twenty (1,120) millimeters) wide.

(2) Each bedroom shall have adequate space to provide a maneuvering space that complies with section 4.2.3.

(3) Each bedroom shall have adequate space to provide a minimum clear floor space of thirty-six (36) inches (nine hundred fifteen (915) millimeters) along each side of the bed and to provide an accessible route complying with section 4.3.3 to each side of each bed.

**6.4 Patient Toilet Rooms.** Where toilet/bath rooms are provided as a part of a patient bedroom, each patient bedroom that is required to be accessible shall have an accessible toilet/bath room that complies with section 4.22 or section 4.23 and shall be on an accessible route.

**7.0 Business and Mercantile.**

**7.1 General.** In addition to the requirements of sections 4.1 to 4.35, the design of all areas used for business transactions with the public shall comply with section 7.0.

**7.2 Sales and Service Counters, Teller Windows, Information Counters.**

(1) In department stores and miscellaneous retail stores where counters have cash registers and are provided for sales or distribution of goods or services to the public, at least one (1) of each type shall have a portion of the counter which is at least thirty-six (36) inches (nine hundred fifteen (915) millimeters) in length with a maximum height of thirty-six (36) inches (nine hundred fifteen (915) millimeters) above the finish floor. It shall be on an accessible route complying with section 4.3. The accessible counters must be dispersed throughout the building or facility.

(2) At ticketing counters, teller stations in a bank, registration counters in hotels and motels, box office ticket counters, and other counters that may not have a cash register but at which goods or services are sold or distributed, either:

(i) a portion of the main counter which is a minimum of

thirty-six (36) inches (nine hundred fifteen (915) millimeters) in length shall be provided with a maximum height of thirty-six (36) inches (nine hundred fifteen (915) millimeters); or

(ii) an auxiliary counter with a maximum height of thirty-six (36) inches (nine hundred fifteen (915) millimeters) in close proximity to the main counter shall be provided; or

(iii) equivalent facilitation shall be provided (e.g., at a hotel registration counter, equivalent facilitation might consist of: (1) provision of a folding shelf attached to the main counter on which an individual with disabilities can write, and (2) use of the space on the side of the counter or at the concierge desk, for handing materials back and forth).

All accessible sales and service counters shall be on an accessible route complying with 4.3.

(3) Reserved.

**7.3 Check-Out Aisles.**

(1) Accessible check-out aisles shall be provided in conformance with the table below:

Total Check-Out Aisles of Each Design	Minimum Number of Accessible Check-Out Aisles (of each design)
1-4	1
5-8	2
8-15	3
Over 15	3, plus 20% of additional aisles

**EXCEPTION:** Where the selling space is under five thousand (5,000) square feet, only one (1) check-out aisle is required to be accessible.

Examples of check-out aisles of different "design" include those which are specifically designed to serve different functions. Different "design" includes, but is not limited to, the length of belt or no belt, or permanent signage designating the aisle as an express lane.

(2) Clear aisle width for accessible check-out aisles shall comply with section 4.2.1 and maximum adjoining counter height shall not exceed thirty-eight (38) inches (nine hundred sixty-five (965) millimeters) above the finish floor. The top of the lip shall not exceed forty (40) inches (one thousand fifteen (1,015) millimeters) above the finish floor.

(3) Signage identifying accessible check-out aisles shall comply with section 4.30.7 and shall be mounted above the check-out aisle in the same location where the check-out number or type of check-out is displayed.

**7.4 Security Bollards.** Any device used to prevent the removal of shopping carts from store premises shall not prevent access or egress to people in wheelchairs. An alternate entry that is equally convenient to that provided for the ambulatory population is acceptable.

**8.0 Libraries.**

**8.1 General.** In addition to the requirements of sections 4.1 to 4.35, the design of all public areas of a library shall

## Proposed Rules

comply with section 8.0, including reading and study areas, stacks, reference rooms, reserve areas, and special facilities or collections.

**8.2 Reading and Study Areas.** At least five percent (5%) or a minimum of one (1) of each element of fixed seating, tables, or study carrels shall comply with sections 4.2 and 4.32. Clearances between fixed accessible tables and between study carrels shall comply with section 4.3.

**8.3 Check-out Areas.** At least one (1) lane at each check-out area shall comply with section 7.2(1). Any traffic control or book security gates or turnstiles shall comply with section 4.13.

**8.4 Card Catalogs and Magazine Displays.** Minimum clear aisle space at card catalogs and magazine displays shall comply with Fig. 55. Maximum reach height shall comply with section 4.2, with a height of forty-eight (48) inches (one thousand two hundred twenty (1,220) millimeters) preferred irrespective of approach allowed.

**8.5 Stacks.** Minimum clear aisle width between stacks shall comply with section 4.3, with a minimum clear aisle width of forty-two (42) inches (one thousand sixty-five (1,065) millimeters) preferred where possible. Shelf height in stack areas is unrestricted (see Fig. 56).

**9.0 Accessible Transient Lodging.** Except as specified in the special technical provisions of this section, accessible transient lodging shall comply with the applicable requirements of sections 4.1 through 4.35. Transient lodging includes facilities or portions thereof used for sleeping accommodations, when not classed as a medical care facility.

**9.1 Hotels, Motels, Inns, Boarding Houses, Dormitories, Resorts, and Other Similar Places of Transient Lodging.**

**9.1.1 General.** All public use and common use areas are required to be designed and constructed to comply with section 4.0.

**EXCEPTION:** Sections 9.1 through 9.4 do not apply to an establishment located within a building that contains not more than five (5) rooms for rent or hire and that is actually occupied by the proprietor of such establishment as the residence of such proprietor.

**9.1.2 Accessible Units, Sleeping Rooms, and Suites.** Accessible sleeping rooms or suites that comply with the requirements of section 9.2 shall be provided in conformance with the table below. In addition, in hotels of fifty (50) or more sleeping rooms or suites that include roll-in showers shall also be provided in conformance with the table below. In addition, in hotels, of fifty (50) or more sleeping rooms or suites, additional accessible sleeping rooms or suites that include a roll-in shower shall also be provided in conformance with the table below. Such accommodations shall comply with the requirements of sections 9.2, 4.21, and Fig. 57(a) or 57(b).

Number of Rooms	Accessible Rooms	Rooms with Roll-In Showers
1 to 25	1	
26 to 50	2	

51 to 75	3	1
76 to 100	4	1
101 to 150	5	2
151 to 200	6	2
201 to 300	7	3
301 to 400	8	4
401 to 500	9	4 plus 1 for each additional 100 over 400
501 to 1,000	2% of total	
1,001 and over	20 plus 1 for each 100 over 1,000	

**9.1.3 Sleeping Accommodations for Persons with Hearing Impairments.** In addition to those accessible sleeping rooms and suites required by section 9.1.2, sleeping rooms and suites that comply with section 9.3 (Visual Alarms, Notification Devices, and Telephones) shall be provided in conformance with the following table:

Number of Elements	Accessible Elements
1 to 2	1
26 to 50	2
51 to 75	3
76 to 100	4
101 to 150	5
151 to 200	6
201 to 300	7
301 to 400	8
401 to 500	9
501 to 1,000	2% of total
1,001 and over	20 plus 1 for each 100 over 1,000

**9.1.4 Classes of Sleeping Accommodations.**

(1) In order to provide persons with disabilities a range of options equivalent to those available to other persons served by the facility, sleeping rooms and suites required to be accessible by section 9.1.2 shall be dispersed among the various classes of sleeping accommodations available to patrons of the place of transient lodging. Factors to be considered include room size, cost, amenities provided, and the number of beds provided.

(2) **Equivalent Facilitation.** For purposes of this section, it shall be deemed equivalent facilitation if the operator of a facility elects to limit construction of accessible rooms to those intended for multiple occupancy, provided that such rooms are made available at the cost of a single-occupancy room to an individual with disabilities who requests a single-occupancy room.

**9.1.5 Reserved.**

**9.2 Requirements for Accessible Units, Sleeping Rooms, and Suites.**

**9.2.1 General.** Accessible units, sleeping rooms, and suites required to be accessible by section 9.1 shall comply with section 9.2.

**9.2.2 Minimum Requirements.** An accessible unit, sleeping room, or suite shall be on an accessible route complying

---

---

## Proposed Rules

---

---

with section 4.3 and have the following accessible elements and spaces.

(1) Accessible sleeping rooms shall have a thirty-six (36) inch (nine hundred fifteen (915) millimeter) clear width maneuvering space located along both sides of a bed, except that where two (2) beds are provided, this requirement can be met by providing a thirty-six (36) inch (nine hundred fifteen (915) millimeter) wide maneuvering space located between the two (2) beds.

(2) An accessible route complying with section 4.3 shall connect all accessible spaces and elements including telephones within the unit, sleeping room, or suite. This is not intended to require an elevator in multistory units as long as the spaces identified in section 9.2.2(6) and 9.2.2(7) are accessible levels and the accessible sleeping area is suitable for dual occupancy.

(3) Doors and doorways designed to allow passage into and within all sleeping rooms, suites, or other covered units shall comply with section 4.13.

(4) If fixed or built-in storage facilities such as cabinets, shelves, closets, and drawers are provided in accessible spaces, at least one (1) of each type provided shall contain storage space complying with section 4.25. Additional storage may be provided outside of the dimensions required by section 4.25.

(5) All controls in accessible units, sleeping rooms, and suites shall comply with section 4.27.

(6) Where provided as part of an accessible unit, sleeping room, or suite, the following spaces shall be accessible and shall be on an accessible route:

- (a) The living area.
- (b) The dining area.
- (c) At least one (1) sleeping area.
- (d) The patio, terrace, or balcony area.

**EXCEPTION:** The requirements of section 4.13.8 and section 4.3.8 do not apply where it is necessary to utilize a higher door threshold or a change in level to protect the integrity of the unit from wind/water damage. Where this exception results in a patio, terrace, or balcony area that is not at an accessible level, equivalent facilitation shall be provided, for example, equivalent facilitation of a hotel patio or balcony might consist of providing raised decking or a ramp to provide accessibility.

(e) At least one (1) full bathroom (i.e., one (1) with a water closet, a lavatory, and a bathtub or shower).

(f) If only half baths are provided, at least one (1) half bath.

(g) Carports, garages, or parking spaces.

(7) Kitchens, Kitchenettes, or Wet Bars. When provided as accessory to a sleeping room or suite, kitchens, kitchenettes, wet bars, or similar amenities shall be accessible. Clear floor space for a front or parallel approach to cabinets, counters, sinks, and appliances shall be provided to comply with section 4.2.4. Countertops and sinks

shall be mounted at a maximum height of thirty-four (34) inches (eight hundred sixty-five (865) millimeters) above the floor. At least fifty percent (50%) of shelf space in cabinets or refrigerator/freezers shall be within the reach ranges of 4.2.5 or 4.2.6 and space shall be designed to allow for the operation of cabinet and/or appliance doors so that all cabinets and appliances are accessible and usable. Controls and operating mechanisms shall comply with 4.27.

(8) Sleeping room accommodations for persons with hearing impairments required by 9.1 and complying with 9.3 shall be provided in the accessible sleeping room or suite.

### 9.3 Visual alarms, Notification Devices and Telephones.

**9.3.1 General.** In sleeping rooms required to comply with this section, auxiliary visual alarms shall be provided and shall comply with 4.28.4. Visual notification devices shall also be provided in units, sleeping rooms, and suites to alert room occupants of incoming telephone calls and a door knock or bell. Notification devices shall not be connected to auxiliary visual alarm signal appliances. Permanently installed telephones shall have volume controls complying with 4.31.5: an accessible electrical outlet within four (4) feet (one thousand two hundred twenty (1,220) millimeters) of a telephone connection shall be provided to facilitate the use of a text telephone.

**9.3.2 Equivalent Facilitation.** For purposes of this section, equivalent facilitation shall include the installation of electrical outlets (including outlets connected to a facility's central alarm system) and telephone wiring in sleeping rooms and suites to enable persons with hearing impairments to utilize portable visual alarms and communication devices provided by the operator of the facility.

**9.4 Other Sleeping Rooms and Suites.** Doors and doorways designed to allow passage into and within all sleeping units or other covered units shall comply with 4.13.5.

**9.5 Transient Lodging in Homeless Shelters, Halfway Houses, Transient Group Homes, and Other Social Service Establishments.**

**9.5.1 New Construction.** In new construction, all public use and common use areas are required to be designed and constructed to comply with section 4. At least one (1) of each type of amenity (such as washers, dryers, and similar equipment installed for the use of occupants) in each common area shall be accessible and shall be located on an accessible route to any accessible unit or sleeping accommodation.

**EXCEPTION:** Where elevators are not provided as allowed in 4.1.3(5), accessible amenities are not required on inaccessible floors as long as one (1) of each type is provided in common areas on accessible floors.

**9.5.2 Reserved.**

**9.5.3 Accessible Sleeping Accommodations in New Construction.** Accessible sleeping rooms shall be provided in conformance with the table in 9.1.2 and shall comply with

**9.2 Accessible Units, Sleeping Rooms and Suites** (where the items are provided). Additional sleeping rooms that comply with **9.3 Sleeping Accommodations for Persons with Hearing Impairments** shall be provided in conformance with the table provided in **9.1.3**. In facilities with multi-bed rooms or spaces, a percentage of the beds equal to the table provided in **9.1.2** shall comply with **9.2.2(1)**.

**10.0 Reserved.**

**11.0 Children’s Facilities.**

**11.1 Application.** This section applies to facilities, or portion of facilities, constructed according to children’s dimensions and anthropometrics for ages 2 through 12. Facilities covered by this section shall comply with the applicable requirements of **4.1** through **4.35** and the special application sections, except as modified or otherwise provided in this section. All public and common use areas covered by this section are required to be designed and constructed to comply with **4.1** through **4.35**, except as modified or otherwise provided in this section. Accessible elements and spaces covered by this section shall be on an accessible route complying with **4.3**, **11.3**, and **11.4**. The specifications in this section are based on children’s dimensions and anthropometrics.

The phrase “constructed according to children’s dimensions and anthropometrics” means where the construction of a facility reflects the size and dimensions, reach ranges, level of strength and stamina, or other characteristics of children. Facilities constructed that do not reflect children’s characteristics are not covered by this section.

**11.2 Reach Ranges.**

**11.2.1 General.** The requirements in **4.2.5** and **4.2.6** are modified by the following provisions.

**11.2.2 Forward and Side Reach.** The high forward or high side reach, and the low forward or low side reach shall comply with A, B, or C in the table below. Selection A, B, or C should correspond to the age range of the primary user group.

**Forward and Side Reach**

<b>A (ages 2 through 4):</b>	High Reach (not more than)–36 inches Low Reach (not less than)–20 inches
<b>B (ages 5 through 8):</b>	High Reach–40 inches Low Reach–18 inches
<b>C (ages 9 through 12):</b>	High Reach–44 inches Low Reach–16 inches

**11.3 Protruding Objects.** The requirements in **4.4.1** are modified by **11.3**. Objects projecting from walls with their leading edges between twelve (12) inches and eighty (80) inches (three hundred five (305) millimeters and two thousand thirty (2,030) millimeters) above the finish floor shall protrude no more than four (4) inches (one hundred (100) millimeters) into walks, halls, corridors, passageways, or aisles. Objects mounted with their leading edges at or

below twelve (12) inches (three hundred five (305) millimeters) above the finish floor may protrude any amount. Free-standing objects mounted on posts or pylons may overhang twelve (12) inches (three hundred five (305) millimeters) maximum from twelve (12) inches to eighty (80) inches (three hundred five (305) millimeters to two thousand thirty (2,030) millimeters) above the ground or finish floor. Protruding objects shall not reduce the clear width of an accessible route or maneuvering space.

**11.4 Handrails at Ramps and Stairs.**

**11.4.1 General.** In addition to the handrails required by **4.8** and **4.9**, a second set of handrails shall be provided complying with **4.8.5** or **4.9.4** and **4.26.2**, except as modified by the following provisions.

**11.4.2 Height.** The top of handrail gripping surfaces shall be mounted between twenty (20) inches and twenty-eight (28) inches (five hundred ten (510) millimeters and seven hundred ten (710) millimeters) above ramp surfaces on stair nosings.

**11.4.3 Size.** The gripping surfaces of handrails shall have a diameter or width of one (1) inch to one and one-fourth (1¼) inches (twenty-five (25) millimeters to thirty (30) millimeters), or the shape shall provide an equivalent gripping surface.

**11.5 Drinking Fountains and Water Coolers.**

**11.5.1 General.** Drinking fountains or water coolers required to be wheelchair accessible by **4.1** shall comply with **4.15**, except as modified by **11.5**. The requirements in **4.15.2** and **4.15.5** are modified by the following provisions.

**11.5.2 Spout Height.** Spouts shall be no higher than thirty (30) inches (seven hundred sixty (760) millimeters), measured from the floor or ground surface to the spout outlet.

**11.5.3 Clearances.** Wall-mounted and post-mounted cantilevered units shall have a clear knee space between the bottom of the apron and the floor or ground at least twenty-four (24) inches (six hundred ten (610) millimeters) high and eight (8) inches (two hundred five (205) millimeters) deep, measured from the leading edge of the fountain. Clear toe space shall be twelve (12) inches (three hundred five (305) millimeters) high minimum, measured from the finish floor. Such units shall also have a minimum clear floor space thirty (30) inches by forty-eight (48) inches (seven hundred sixty (760) millimeters by one thousand two hundred twenty (1,220) millimeters) to allow a forward approach to the unit. The clear floor space may extend a maximum of fourteen (14) inches (three hundred five (305) mm) underneath the fountain.

**11.6 Water Closets, Toilet Seats, Grab Bars, and Toilet Paper Dispensers.**

**11.6.1 General.** Water closets required to be accessible by **4.22.4** shall comply with **4.16**, except as modified by **11.6**. The requirements in **4.16** and **4.26.2** are modified by the following provisions.

**11.6.2 Placement.** The centerline and seat height of the water closet and the centerline height of the grab bars and toilet paper dispenser shall comply with A, B, or C in the

---

---

## Proposed Rules

---

---

table below. Selection of A, B, or C should correspond to the age range of the primary user group. The centerline of water closets shall be measured from one (1) side wall or stall partition.

Specifications for Water Closets, Toilet Seats, Grab Bars, and Toilet Paper Dispensers

A: Ages 2 through 4

Water closet centerline—12 inches

Toilet seat height—11 inches to 12 inches

Grab bar height—18 inches to 20 inches

Dispenser height—14 inches

B: Ages 5 through 8

Water closet centerline—12 inches to 15 inches

Toilet seat height—12 inches to 15 inches

Grab bar height—20 inches to 25 inches

Dispenser height—14 inches to 17 inches

C: Ages 9 through 12

Water closet centerline—15 inches to 18 inches

Toilet seat height—15 inches to 17 inches

Grab bar height—25 inches to 27 inches

Dispenser height—17 inches to 19 inches

**11.6.3 Grab Bar Size.** The diameter or width of the gripping surface of a grab bar shall be one (1) inch to one and one-fourth (1¼) inches (twenty-five (25) mm to thirty (30) mm), or the shape shall have an equivalent gripping surface.

**11.6.4 Flush Controls.** Flush controls shall be located within the reach range specified by 11.2.

**11.7 Toilet Stalls.**

**11.7.1 General.** Toilet stalls required to be accessible by 4.22.4 shall comply with 4.17, except as modified by 11.7. The requirements in 4.17.2, 4.17.3, 4.17.4, 4.17.6, and 4.26.2 are modified by the following provisions.

**11.7.2 Water Closets.** Water closets in accessible stalls shall comply with 11.6.

**11.7.3 Depth.** Standard stalls with floor-or-wall-mounted water closets shall have a depth of fifty-nine (59) inches (one thousand five hundred (1,500) millimeters) minimum. Standard stalls at the end of a row with floor-or-wall-mounted water closets shall have a depth of fifty-nine (59) inches (one thousand five hundred (1,500) millimeters) in addition to the minimum thirty-six (36) inches (nine hundred fifteen (915) millimeters) required for the stall door.

**11.7.4 Toe Clearance.** In standard stalls of minimum dimension, the front partition and at least one (1) side partition shall provide a toe clearance of twelve (12) inches (three hundred five (305) millimeters) minimum above the finish floor. If the depth of the stall is greater than sixty (60) inches (one thousand five hundred twenty-five (1,525) millimeters), then the toe space is not required.

**11.7.5 Grab Bars.** Grab bar mounting heights shall comply with the heights specified in 11.6. The diameter or width of the gripping surfaces of a grab bar shall be one (1) inch to one and one-fourth (1¼) inches (twenty-five (25) millimeters to thirty (30) millimeters), or the shape shall provide an equivalent gripping surface.

**11.8 Lavatories and Mirrors.**

**11.8.1 General.** Lavatories and mirrors required to be accessible by 4.22.6 and 4.23.6 shall comply with 4.19, except as modified by 11.8. The requirements in 4.19.2, 4.19.3, and 4.19.6 are modified by the following provisions.

**11.8.2 Height and Clearances.** Lavatories shall be mounted with the rim or counter surface no higher than thirty (30) inches (seven hundred sixty (760) millimeters) above the finish floor. A clearance of twenty-seven (27) inches (six hundred eighty-five (685) millimeters) minimum measured from the finish floor to the bottom of the apron shall be provided. Minimum clear knee space twenty-four (24) inches (six hundred ten (610) millimeters) high, measured from the finish floor, and eight (8) inches (two hundred five (205) millimeters) deep, measured from the leading edge of the lavatory, shall be provided. Clear toe space shall be twelve (12) inches (three hundred five (305) millimeters) high minimum, measured from the finish floor.

**11.8.3 Clear Floor Space.** Clear floor space shall extend a maximum of fourteen (14) inches (three hundred fifty-five (355) millimeters) underneath the lavatory.

**11.8.4 Mirrors.** Mirrors shall be mounted with the bottom edge of the reflecting surface no higher than thirty-four (34) inches (eight hundred sixty-five (865) millimeters) above the finish floor.

**11.9 Storage.**

**11.9.1 General.** Fixed storage facilities such as lockers, cabinets, shelves, closets, and drawers required to be accessible by 4.1 shall comply with 4.25, except as modified by 11.9. The requirements in 4.25.3 are modified by the following provisions.

**11.9.2 Height.** Accessible storage spaces shall be within at least one (1) of the reach ranges specified in 11.2. Clothes rods, hooks, or shelves shall be a maximum of thirty-six (36) inches (nine hundred fifteen (915) mm) above the finish floor for a side approach.

**11.10 Fixed or Built-in Seating and Tables.**

**11.10.1 General.** Fixed or built-in seating or tables required to be accessible by 4.1 shall comply with 4.32, except as modified by 11.10. The requirements in 4.32.2, 4.32.3, and 4.32.4 are modified by the following provisions.

**11.10.2 Seating.** Clear floor space shall not overlap knee space by more than fourteen (14) inches (three hundred fifty-five (355) millimeters).

**11.10.3 Knee Clearances.** Knee clearance at least twenty-four (24) inches (six hundred ten (610) millimeters) high, thirty (30) inches (seven hundred sixty (760) millimeters) wide, and fourteen (14) inches (three hundred fifty-five (355) millimeters) deep shall be provided.

**11.10.4 Height of Tables or Counters.** The tops of accessible tables and counters shall be from twenty-six (26) inches to thirty (30) inches (six hundred sixty (660) millimeters to seven hundred sixty (760) millimeters) above the finish floor or ground.



[The following tables and figures were printed with the best available copy provided by the fire prevention and building safety commission.]

Table 1 Graphic Conventions	
Convention	Description
	Typical dimension line showing U.S. customary units (1/8 inches) above the line and 3 units (in millimeters) below
	Dimensions for short distances indicated on extended line
	Dimension line showing alternate dimensions required
	Direction of approach
	Maximum
	Minimum
	Boundary of clear floor area
	Centerline

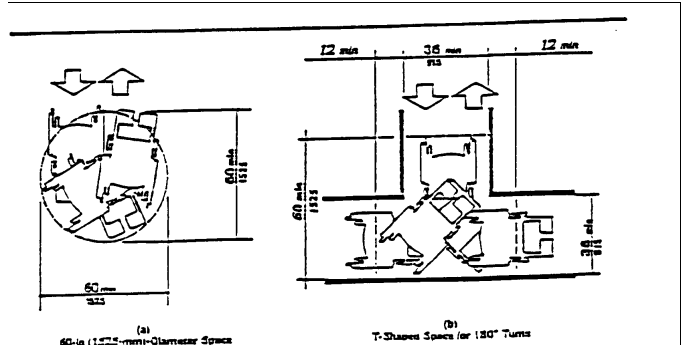

Fig. 3  
Wheelchair Turning Space

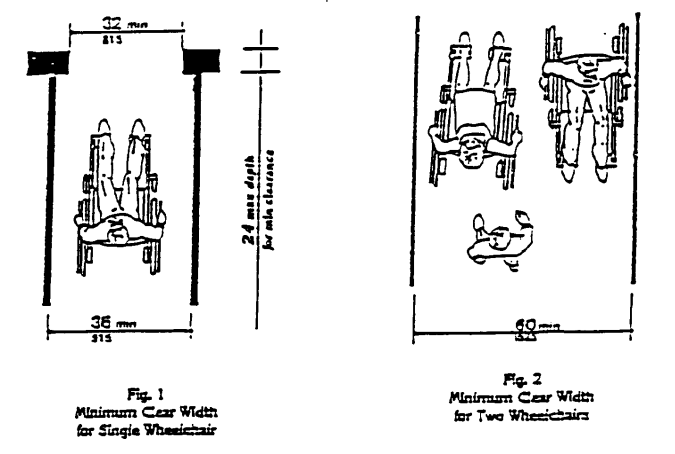

Fig. 1  
Minimum Clear Width  
for Single Wheelchair

Fig. 2  
Minimum Clear Width  
for Two Wheelchairs

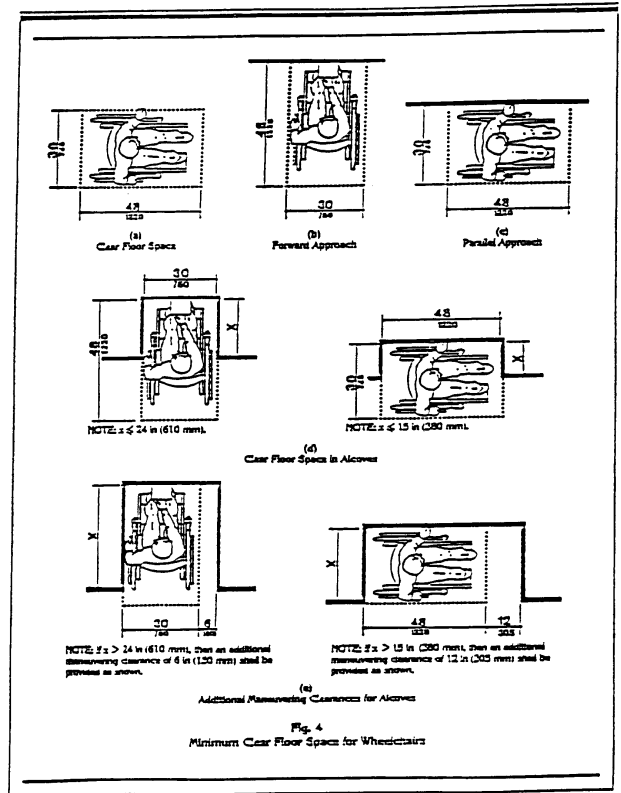
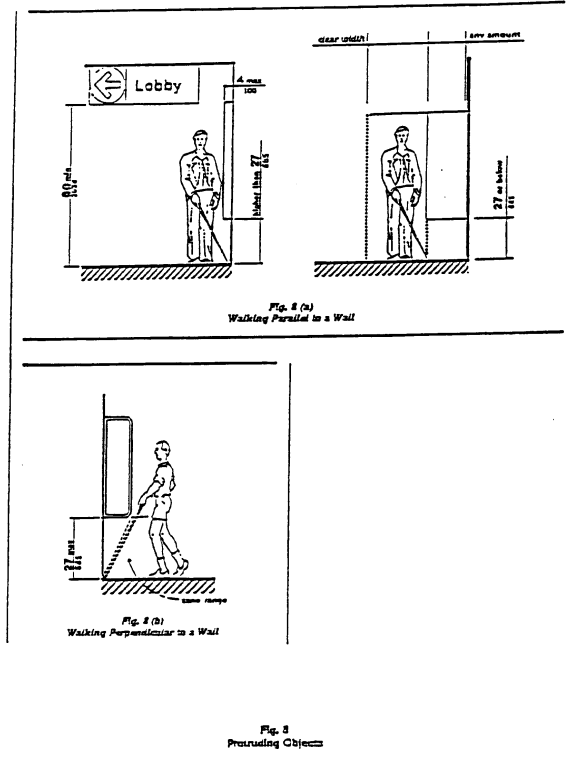
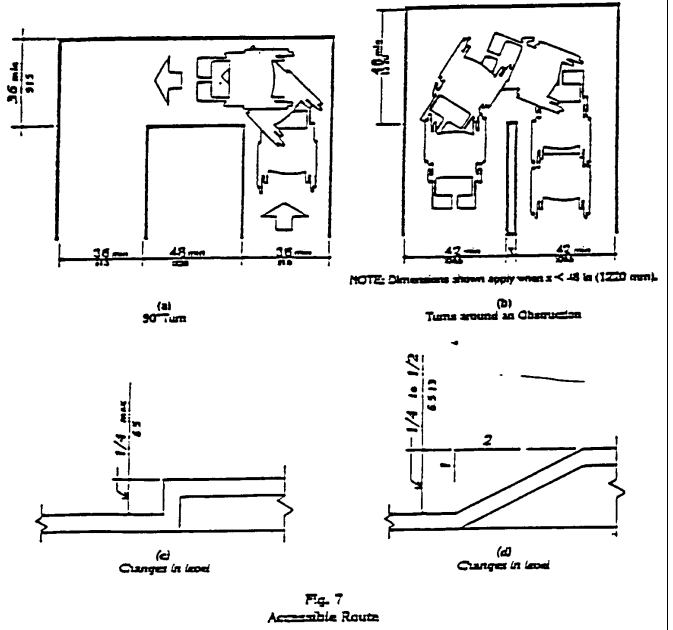
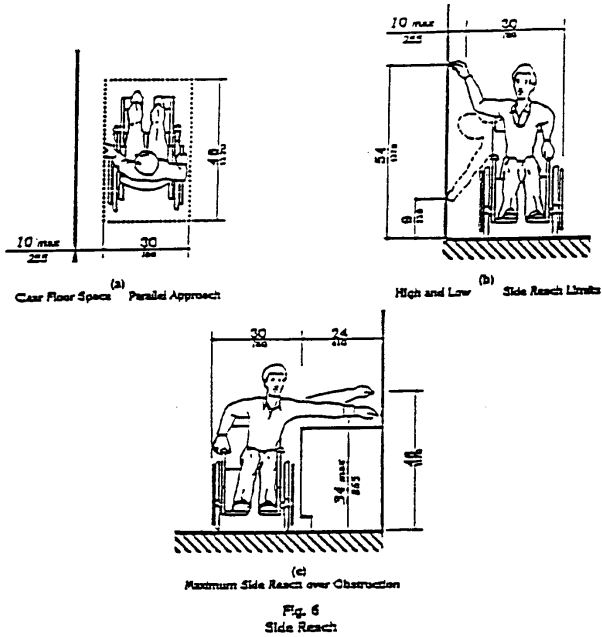
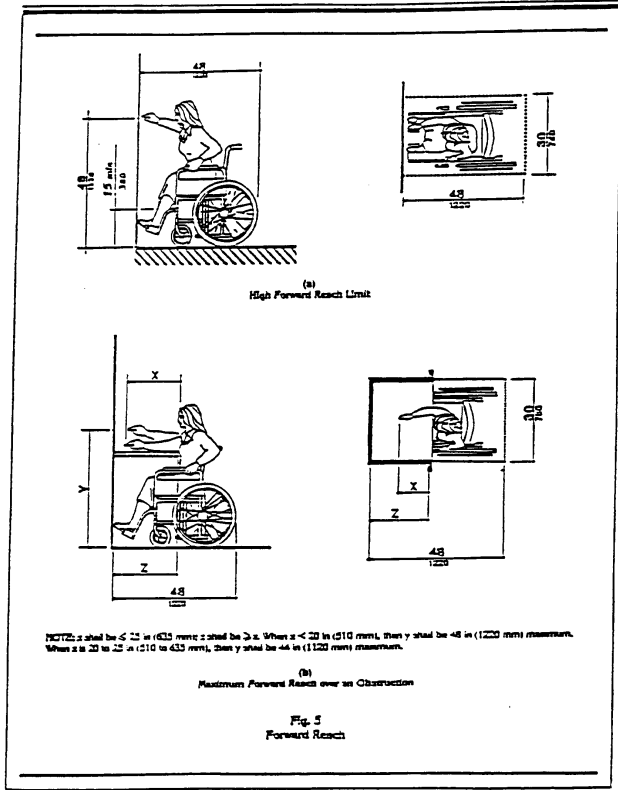

Fig. 4  
Minimum Clear Floor Space for Wheelchairs

# Proposed Rules



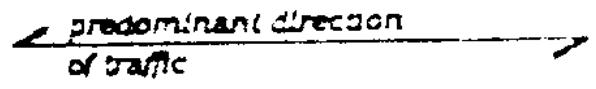
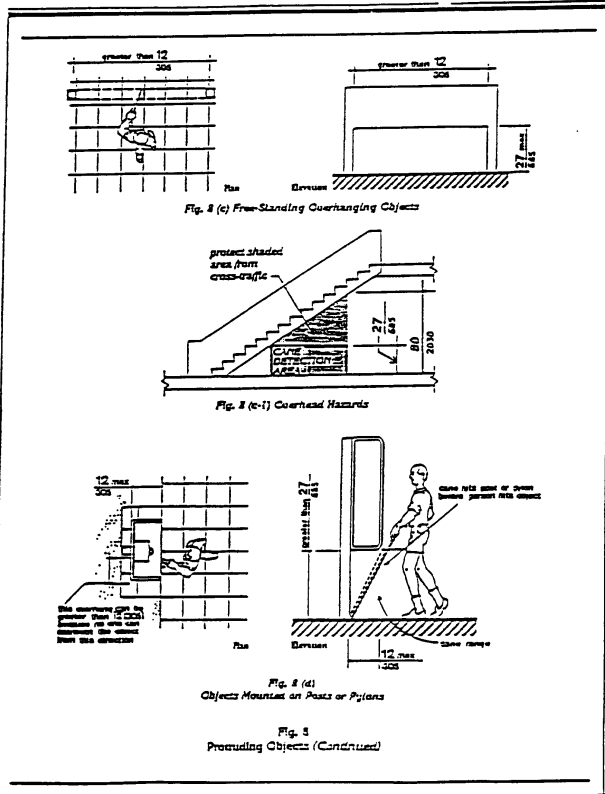

Fig. 8 (g) Gratings

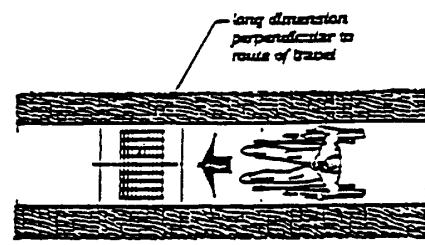

Fig. 8(h)

FIGURE 9 (RESERVED)

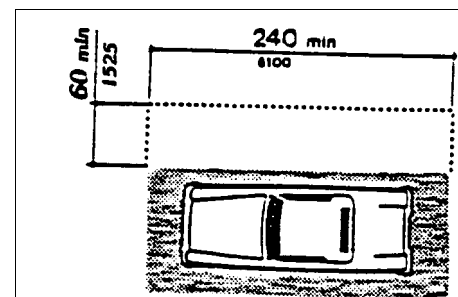

Fig. 10 Access Aisle at Passenger Loading Zones

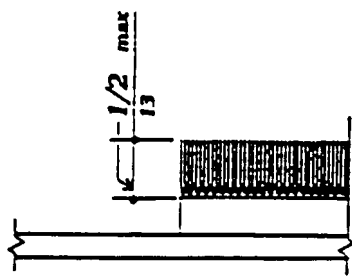

Fig. 8 (f) Carpet Pile Thickness

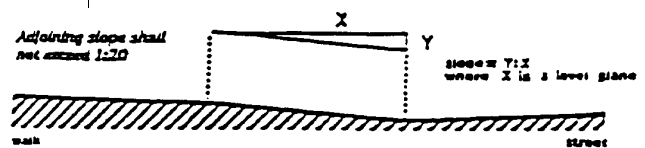

Fig. 11 Measurement of Curb Ramp Slopes

# Proposed Rules

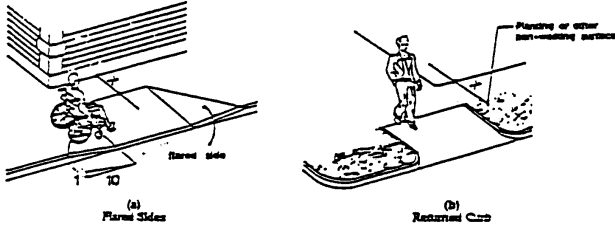

Fig. 12  
Sides of Curb Ramps

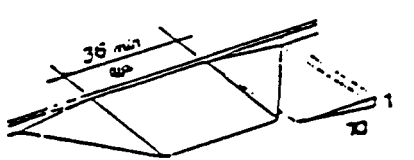

Fig. 13  
Built-Up Curb Ramp

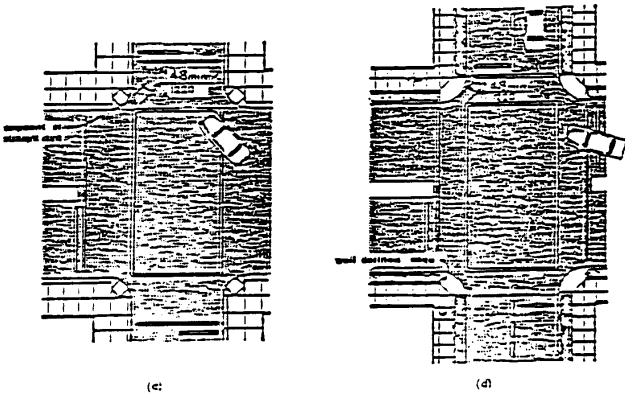
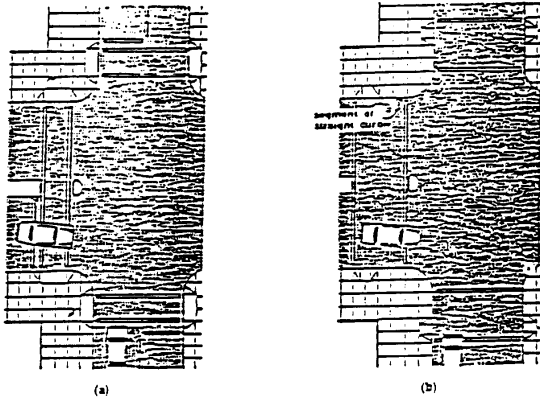
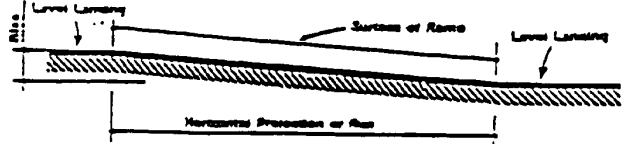

Fig. 15  
Curb Ramps at Marked Crossings



Slope	Maximum Rise		Maximum Horizontal Projection	
	in	mm	ft	m
1:12 to < 1:16	10	260	10	9
1:16 to < 1:20	20	500	40	12

Fig. 16

## Components of a Single Ramp Run and Sample Ramp Dimensions

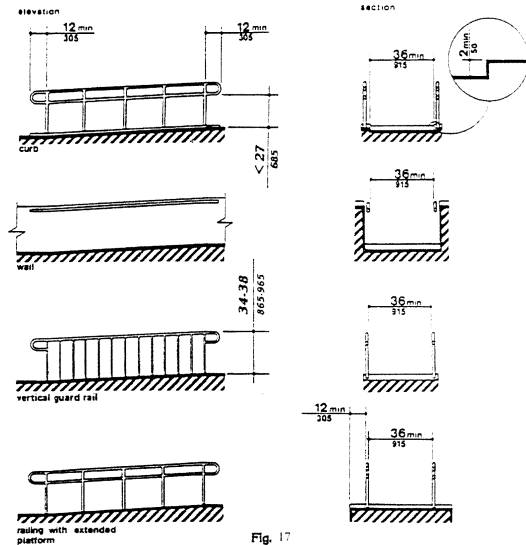

Fig. 17  
Examples of Edge Protection and Handrail Extensions

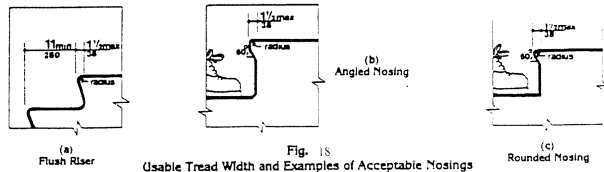
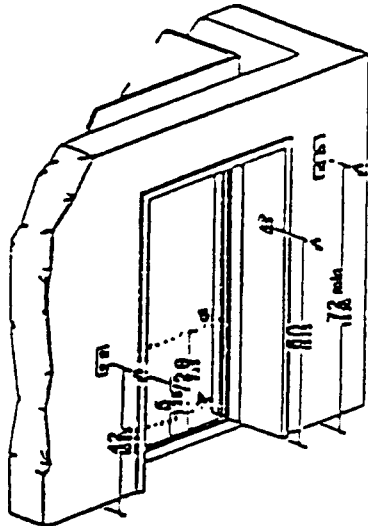
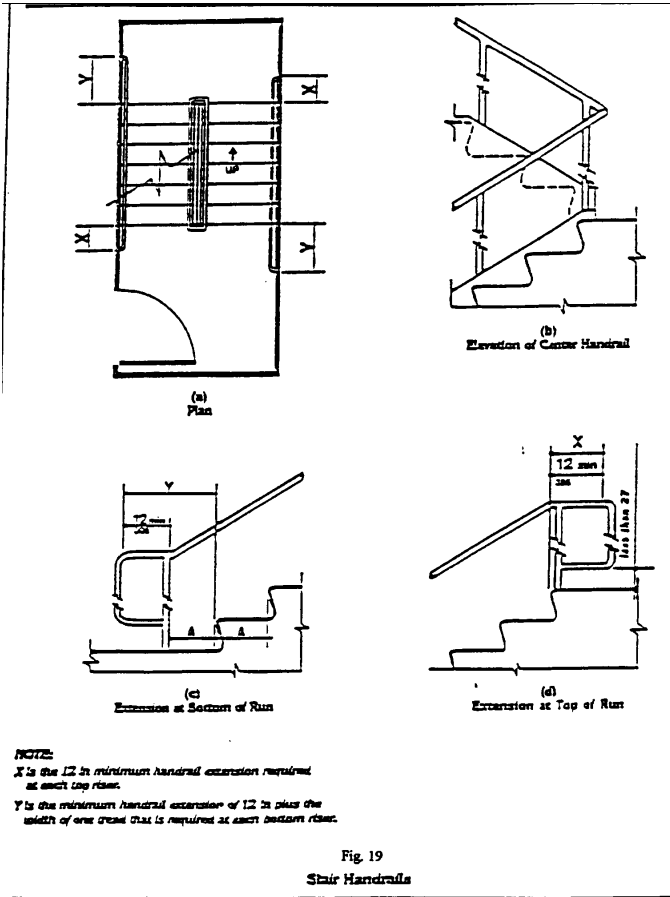

Fig. 18  
Usable Tread Width and Examples of Acceptable Nosings



**NOTE:** The automatic door reopening device is activated if an object passes through either line A or line B. Line A and line B represent the vertical locations of the door reopening device not requiring contact.

Fig. 20  
Hoistway and Elevator Entrances

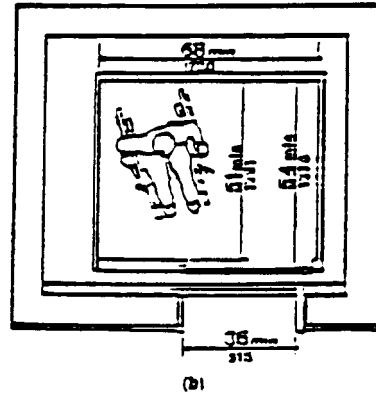
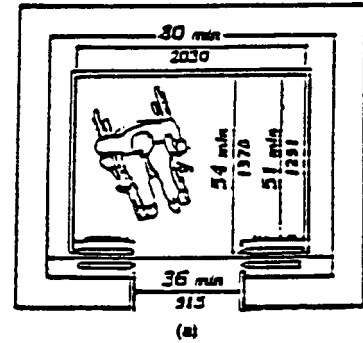
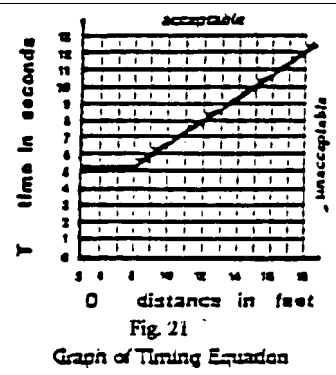

Fig. 22  
Minimum Dimensions of Elevator Cars

# Proposed Rules

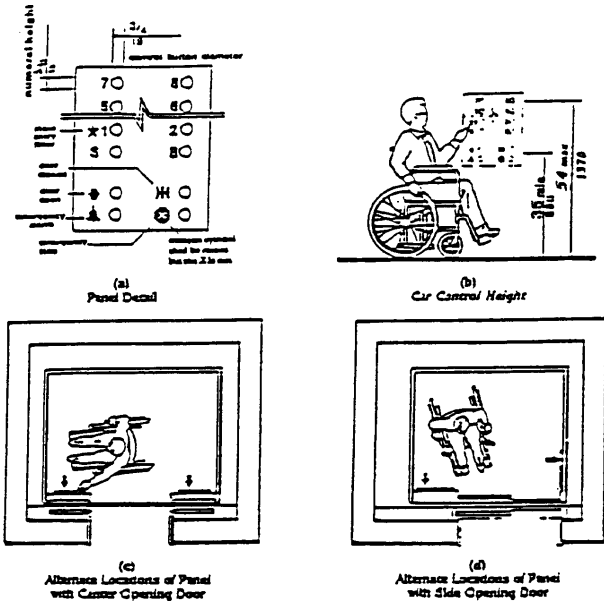

Fig. 23  
Car Controls

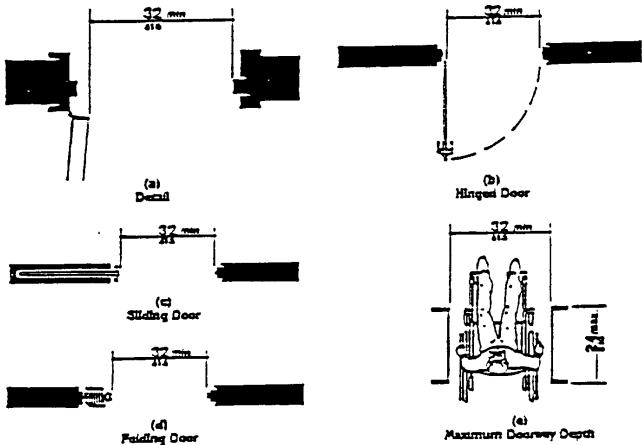

Fig. 24  
Clear Doorway Width and Depth

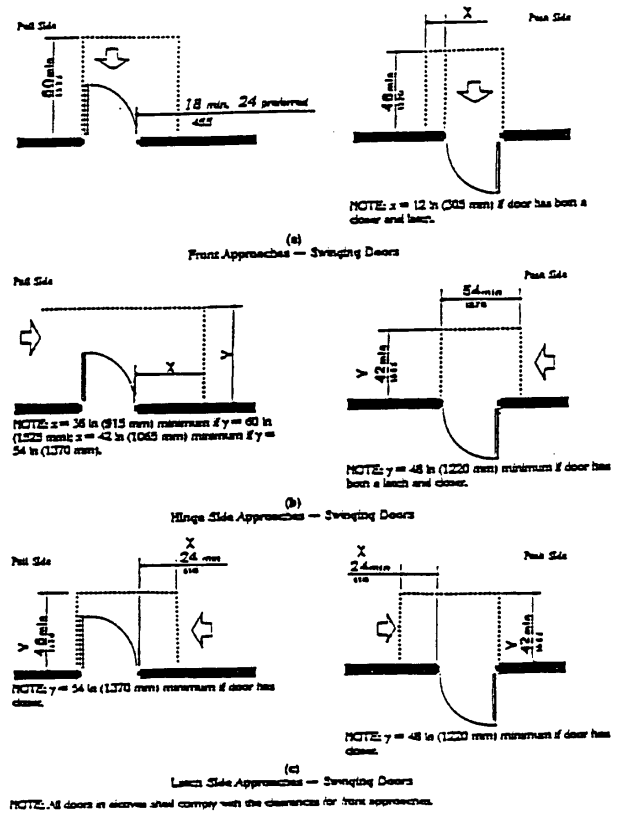

Fig. 25  
Maneuvering Clearances at Doors

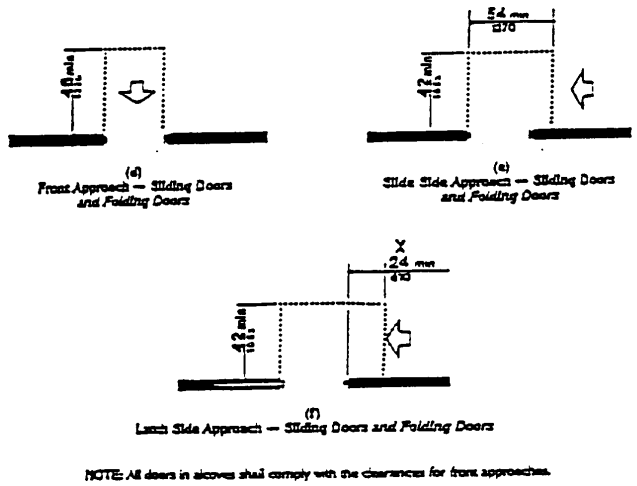

Fig. 25  
Maneuvering Clearances at Doors (Continued)

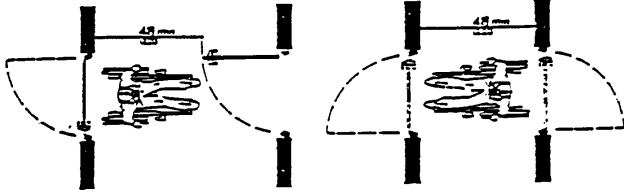
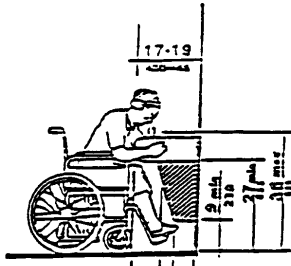
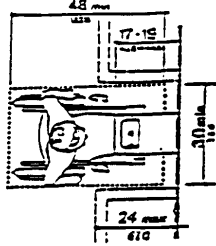

Fig. 26  
Two Hinged Doors in Series



(a) Seated Height and Knee Clearance  
equipment permitted in shaded area



(b) Clear Floor Space

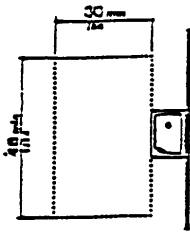

(c) Free-Standing Fountain or Cooler

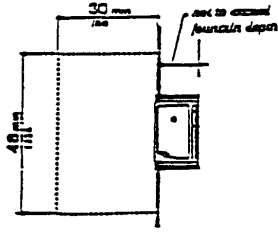

(d) Built-in Fountain or Cooler

Fig. 27  
Drinking Fountains and Water Coolers

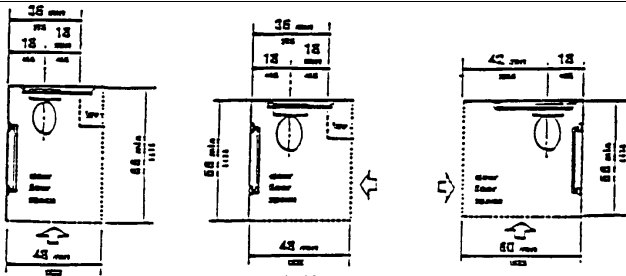

Fig. 28

Clear Floor Space at Water Closets

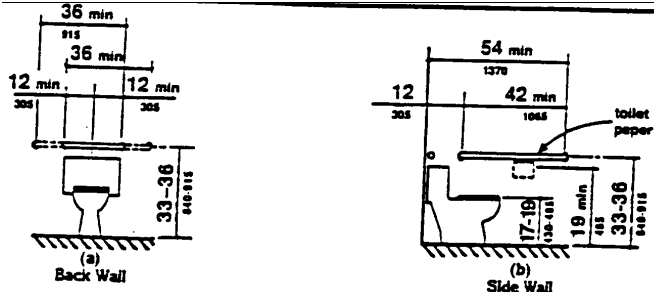
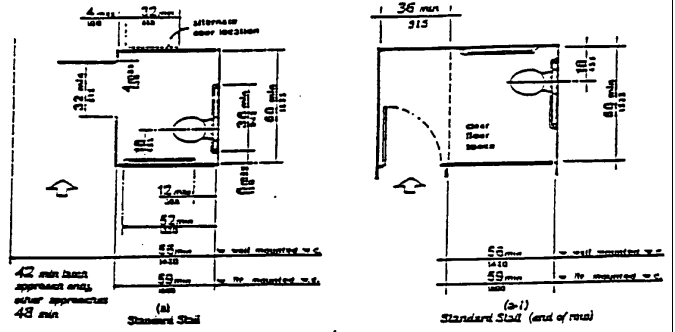
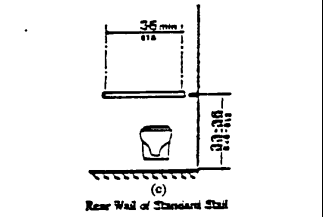

Fig. 29  
Grab Bars at Water Closets



RESERVED  
(b)



Rear Wall of Standard Stall

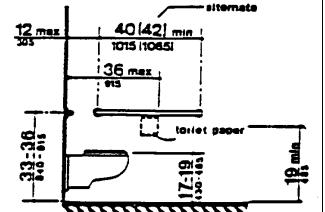

Fig. 30  
Toilet Stalls

Side Walls

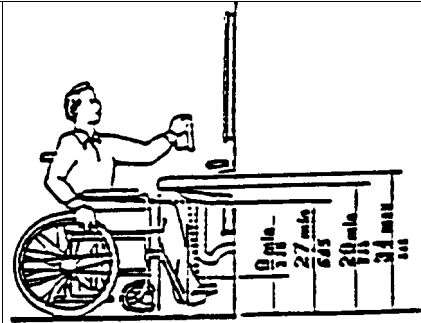

Fig. 31  
Lavatory Clearances

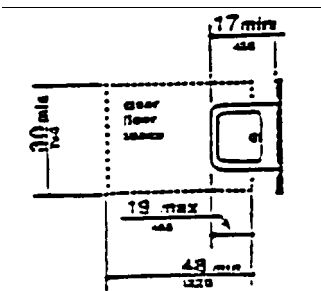
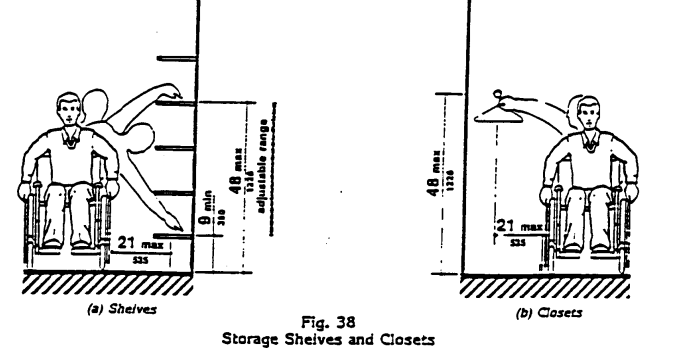
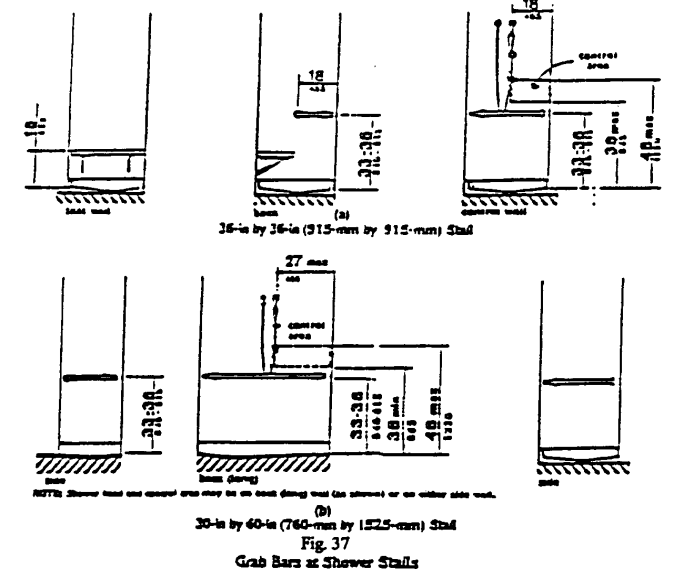
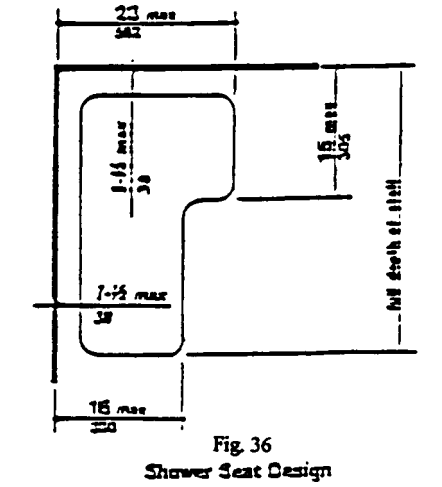
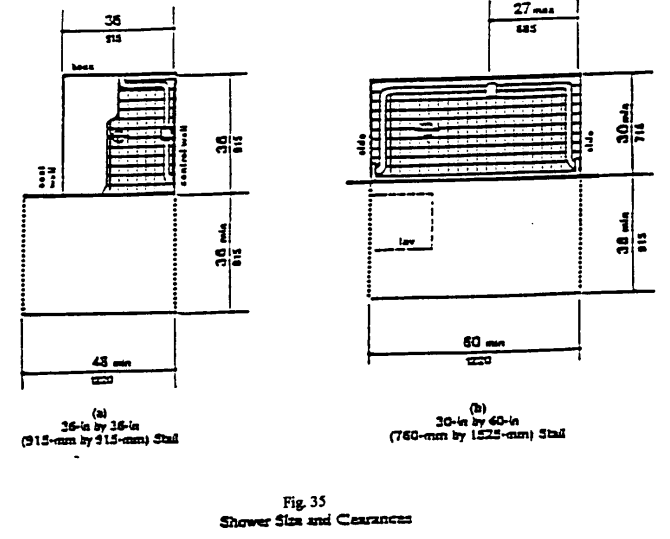
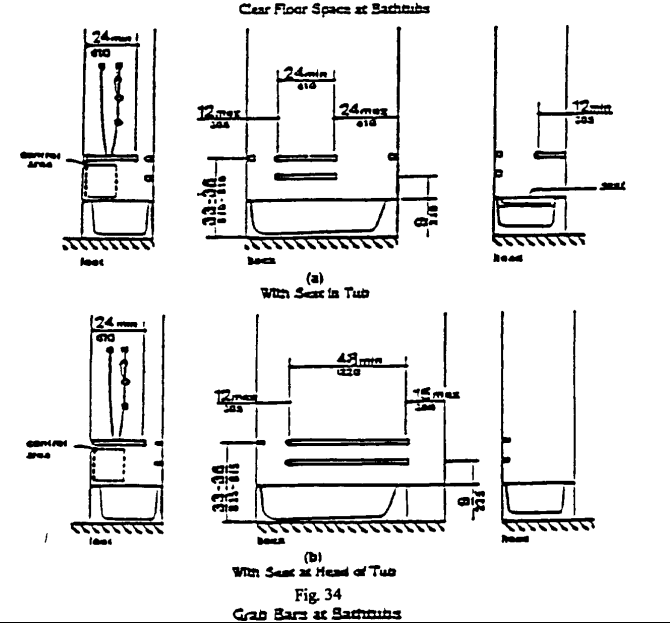
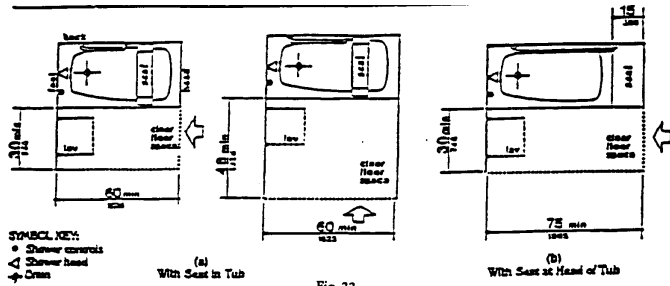
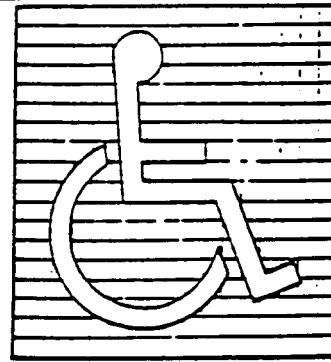
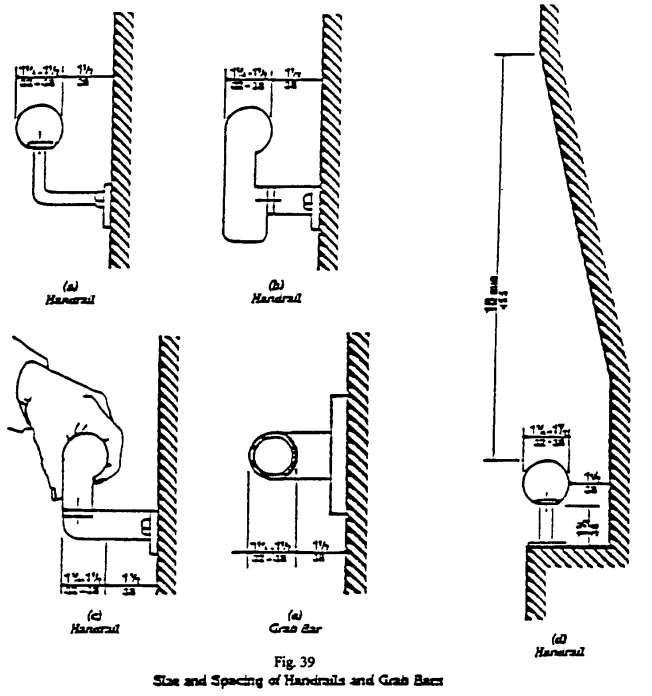

Fig. 32  
Clear Floor Space at Lavatories

# Proposed Rules







Proportions  
International Symbol of Accessibility



Display Conditions  
International Symbol of Accessibility

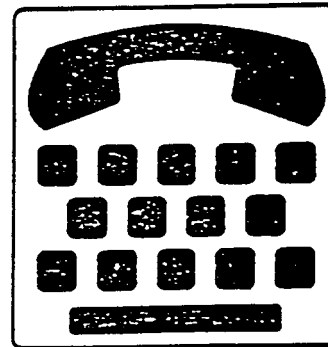

International TDD Symbol



International Symbol of Access for Hearing Loss

Fig. 43  
International Symbols

# Proposed Rules

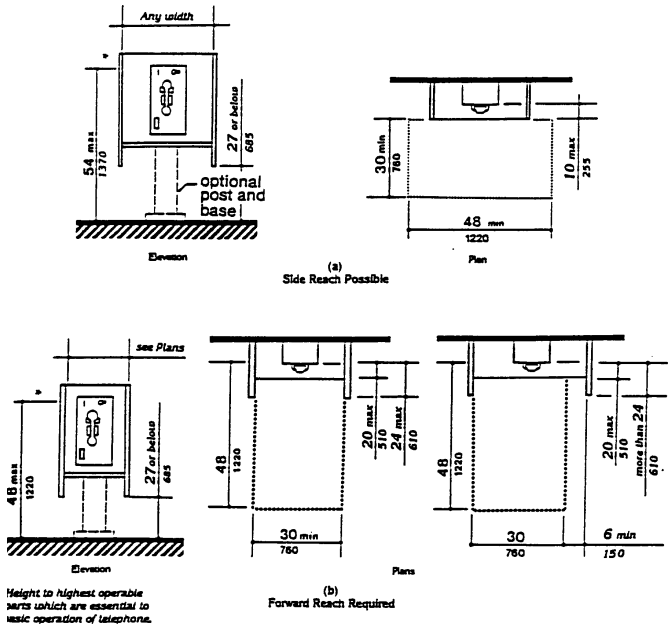

Fig. 44  
Mounting Heights and Clearances for Telephones

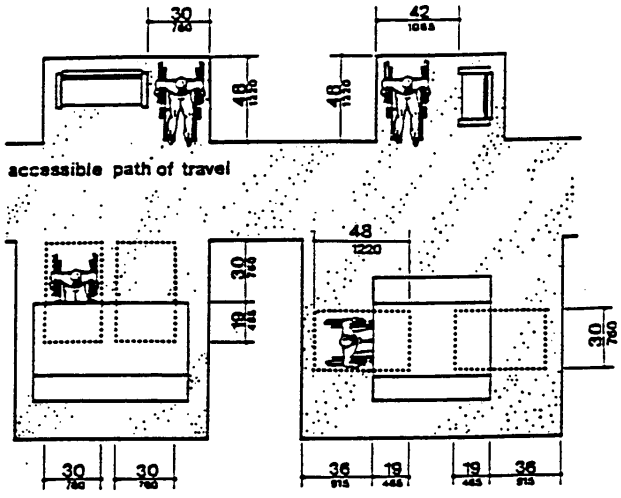

Fig. 45  
Minimum Clearances for Seating and Tables

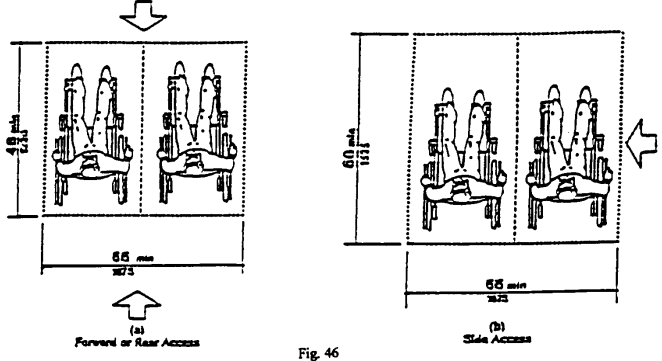

Fig. 46  
Space Requirements for Wheelchair Seating Spaces in Series

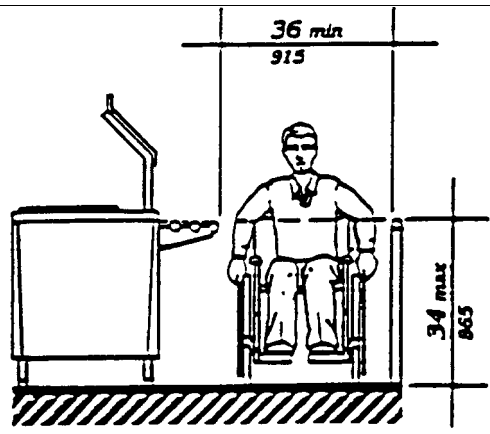

Fig. 53  
Food Service Lines

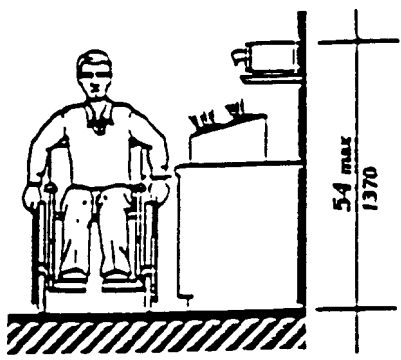

Fig. 54  
Tablecare Areas

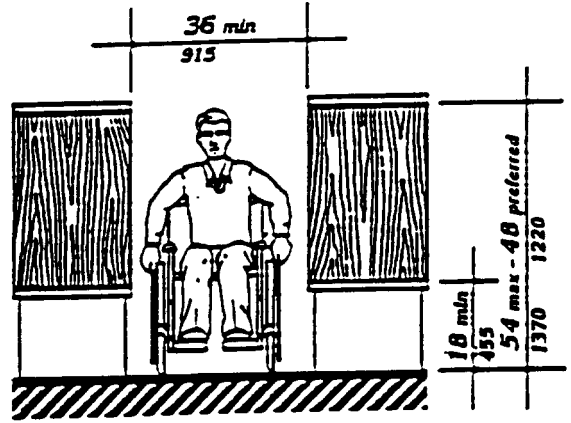

Fig. 55  
Card Catalog

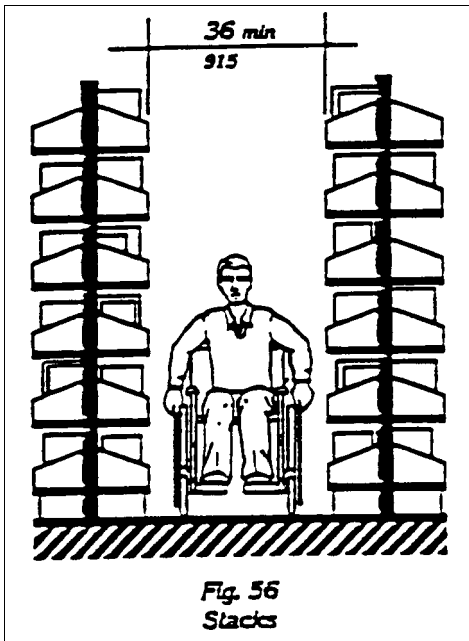

Fig. 56  
Stacks

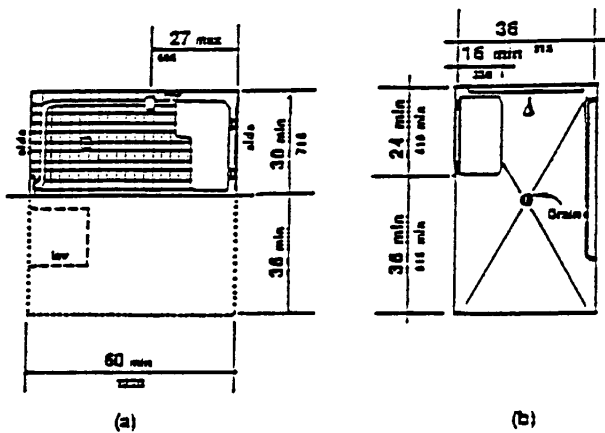

Fig. 57  
Roll-in Shower with Folding Seat

**CHAPTER 11 - PART 2 - ACCESSIBILITY FOR COVERED MULTIFAMILY DWELLINGS**

**Subpart A**

**1.1 Purpose.** The purpose of this part is to implement a rule within the statutory authority of IC 22-13-2-2 and IC 22-13-4-1 that is compatible with the Fair Housing Act (Title VIII of the Civil Rights Act of 1988, 42 U.S.C. 3535(d)). The act prohibits discrimination on the basis of disability and requires that covered multifamily dwellings be accessible by persons with a disability.

**1.2 Scope.** Part 2 applies only to the design and construction of Class I covered multifamily dwellings.

**2.0 Definitions.**

**ACCESSIBLE**, when used with respect to the public and common use areas of a building containing covered multifamily dwellings, means that the public or common use areas of the building can be approached and entered by persons with a disability.

**ACCESSIBLE ROUTE** means a continuous unobstructed path connecting accessible elements and spaces in a building or within a site that can be negotiated by a person with a disability using a wheelchair. Interior accessible routes may include corridors, floors, ramps, elevators, and lifts. Exterior accessible routes may include parking access aisles, curb ramps, walks, ramps, and lifts. A route that complies with the appropriate requirements of CABO/ANSI A117.1 1992 is an accessible route.

**ADAPTABLE DWELLING UNITS**, when used with respect to covered multifamily dwellings, means dwelling units that include the features of adaptable design specified in section 3.0(c)(2) through 3.0(c)(3).

**BATHROOM** means a bathroom which includes a water closet (toilet), lavatory (sink), and bathtub or shower. It does not include single-fixture facilities or those with only a water closet and lavatory. It does include a compartmented bathroom. A compartmented bathroom is one in which the fixtures are distributed among interconnected rooms. A compartmented bathroom is considered a single unit and is subject to the requirements for bathrooms.

**BUILDING**, for the purpose of this part, means a structure, facility, or portion thereof that contains or serves four (4) or more dwelling units.

**BUILDING ENTRANCE ON AN ACCESSIBLE ROUTE** means an accessible entrance to a building within the site where the covered multifamily dwelling is located that is connected by an accessible route to public transportation stops, to parking or passenger loading zones, or to public streets or sidewalks, if available. A building entrance that complies with CABO/ANSI A117.1 1992 complies with the requirements of this paragraph.

CABO/ANSI A117.1-1992 as adopted by reference in subpart B of part 2 refers to the American National Standard-Accessible and Usable Buildings and Facilities CABO/ANSI A117.1-1992.

**CLEAR** means unobstructed.

**COMMON USE AREA** means rooms, spaces, or elements inside or outside of a building that are made available to the residents of a building or the guests thereof. These areas include hallways, lounges, lobbies, laundry rooms, refuse rooms, mail rooms, recreational areas, and passageways among and between buildings.

**COVERED MULTIFAMILY DWELLINGS** means buildings consisting of four (4) or more dwelling units if such buildings have one (1) or more elevators; and ground floor dwelling units in other buildings consisting of four (4) or more dwelling units. Dwelling units within a single structure separated by area separation walls do not constitute separate buildings.

**DWELLING UNIT**, for the purpose of this part, means a single unit of residence for a household of one (1) or more persons. Examples of dwelling units covered by this part include:

---

---

## Proposed Rules

---

---

- (1) condominiums;
- (2) an apartment unit within an apartment building;
- (3) other types of dwellings in which sleeping accommodations are provided but toileting or cooking facilities are shared by occupants of more than one (1) room or portion of the dwelling.

**ENTRANCE** means any exterior access point to a building or portion of a building used by residents for the purpose of entering. For purposes of this chapter, an entrance does not include a door to a loading dock or a door used primarily as a service entrance, even if residents without disabilities occasionally use that door to enter.

**FINISHED GRADE**, for purposes of this part, means the ground surface of the site after all construction, leveling, grading, and development has been completed.

**GROUND FLOOR** means a floor of a building with a building entrance on an accessible route. A building may have one (1) or more ground floors. Where the first floor containing dwelling units in a building is above grade, all units on that floor must be served by a building entrance on an accessible route. This floor will be considered to be a ground floor.

**LOFT** means:

- (1) an intermediate level between the floor and ceiling of any story located within a room or rooms of a dwelling; and
- (2) does not contain the only:
  - (A) bathing facility;
  - (B) lavatory;
  - (C) water closet;
  - (D) living area;
  - (E) eating area; or
  - (F) cooking area;within the dwelling unit.

**MULTISTORY DWELLING UNIT** means a dwelling unit with finished living space located on one (1) floor and the floor or floors immediately above or below it.

**POWDER ROOM** means a room with only a water closet (toilet) and lavatory (sink).

**PUBLIC AREAS** means interior or exterior rooms or spaces of a building that are made available to the general public.

**SINGLE-STORY DWELLING UNIT** means a dwelling unit with all finished living space located on one (1) floor.

**SITE** means a parcel of land bounded by a property line or a designated portion of a public right-of-way.

**SLOPE** means the relative steepness of the land between two (2) points.

**STORY**, for the purposes of this part, means that portion of a dwelling unit between the upper surface of any floor and the upper surface of the floor next above, or the roof of the unit. Within the context of dwelling units, the terms "story" and "floor" are synonymous.

**UNDISTURBED SITE** means before construction, leveling, grading, or development associated with the current project.

**VEHICULAR OR PEDESTRIAN ARRIVAL POINTS** means public or resident parking areas, public transportation stops, passenger loading zones, and streets or sidewalks within the site where the covered multifamily dwelling is located.

**VEHICULAR ROUTE** means a route intended for vehicular traffic, such as a street, driveway, or parking lot, within the site where the covered multifamily dwelling is located.

### 3.0 Design and Construction Requirements.

(a) Covered multifamily dwellings shall be designed and constructed to have at least one (1) building entrance on an accessible route unless it is impractical to do so because of the terrain or unusual characteristics of the site.

(b) Reserved.

(c) All covered multifamily dwellings with a building entrance on an accessible route shall be designed and constructed in such a manner that:

- (1) the public and common use areas are readily accessible to persons with a disability;
- (2) all the doors designed to allow passage into and within all premises are sufficiently wide to allow passage by persons with a disability in wheelchairs;
- (3) all premises within covered multifamily dwelling units contain the features of adaptable design, such as:
  - (i) an accessible route into and through the covered dwelling unit;
  - (ii) light switches, electrical outlets, thermostats, and other environmental controls in accessible locations;
  - (iii) reinforcements in bathroom walls to allow later installation of grab bars around the toilet, tub, shower stall, and shower seat, where such facilities are provided; and
  - (iv) kitchens and bathrooms such that an individual in a wheelchair can maneuver about the space.

(d) Reserved.

(e) Compliance with the appropriate requirements of CABO/ANSI A117.1 1992 will satisfy the requirements of paragraph (c)(3).

### 4.0 Reserved.

### 5.0 Guidelines.

#### Requirement 1. Accessible Building Entrance on an Accessible Route.

(1) **Building entrance.** Each building on a site shall have at least one (1) building entrance on an accessible route unless prohibited by the terrain, as provided in paragraph (2)(a)(i) or (2)(a)(ii), or unusual characteristics of the site, as provided in paragraph (2)(b). This requirement applies both to a single building on a site and to multiple buildings on a site.

(a) **Separate Ground Floor Unit Entrances.** When a ground floor unit of a building has a separate entrance, each such ground floor unit shall be served by an accessible route, except for any unit where the terrain

or unusual characteristics of the site prohibit the provision of an accessible route to the entrance of that unit.

(b) **Multiple Entrances.** Only one (1) entrance is required to be accessible to any one (1) ground floor of a building, except in cases where an individual dwelling unit has a separate exterior entrance, or where the building contains clusters of dwelling units, with each cluster sharing a different exterior entrance. In every case, the accessible entrance shall be on an accessible route to the dwelling units it serves.

(2) **Site impracticality.** Covered multifamily dwellings with elevators shall be designed and constructed to provide at least one (1) accessible entrance on an accessible route, regardless of terrain or unusual characteristics of the site. Covered multifamily dwellings without elevators shall be designed and constructed to provide at least one (1) accessible entrance on an accessible route unless terrain or unusual characteristics of the site are such that the following conditions are found to exist:

(a) **Site impracticality due to terrain.** There are two (2) alternative tests for determining site impracticality due to terrain: the individual building test provided in paragraph (I), or the site analysis test provided in paragraph (ii). A site with a single building having a common entrance for all units shall be analyzed as described in paragraph (I). All other sites, including a site with a single building having multiple entrances serving either individual dwelling units or clusters of dwelling units, may be analyzed using the methodology in either paragraph (I) or paragraph (ii). For these sites for which either test is applicable, regardless of which test is selected, at least twenty percent (20%) of the total ground floor units in nonelevator buildings, on any site, shall comply with Chapter 11, Part 2.

(i) **Individual building test.** It is impractical to provide an accessible entrance served by an accessible route when the terrain of the site is such that:

- (A) the slopes of the undisturbed site measured between the planned entrance and all vehicular or pedestrian arrival points within fifty (50) feet of the planned entrance exceed ten percent (10%); and
- (B) the slopes of the planned finished grade measured between the entrance and all vehicular or pedestrian arrival points within fifty (50) feet of the planned entrance also exceed ten percent (10%).

If there are no vehicular or pedestrian arrival points within fifty (50) feet of the planned entrance, the slope for the purpose of this paragraph (I) will be measured to the closest vehicular or pedestrian arrival point.

For purposes of this part, vehicular or pedestrian arrival points include public or resident parking areas and passenger loading zones, streets, or sidewalks. To determine site impracticality, the slope would be measured at ground level from the point of the planned entrance on a straight line to

each vehicular or pedestrian arrival point that is within fifty (50) feet of the planned entrance or, if there are no vehicular or pedestrian arrival points within that specified area, the vehicular or pedestrian arrival point closest to the planned entrance. In the case of sidewalks, the closest point to the entrance will be where a public sidewalk entering the site intersects with the sidewalk to the entrance. In the case of resident parking areas, the closest point to the planned entrance will be measured from the entry point to the parking area that is located closest to the planned entrance.

(ii) **Site analysis test.** Alternatively, for a site having multiple buildings, or a site with a single building with multiple entrances, impracticality of providing an accessible entrance served by an accessible route can be established by the following steps:

(A) The percentage of the total building area of the undisturbed site with a natural grade less than ten percent (10%) slope shall be calculated. The analysis of the existing slope (before grading) shall be done on a topographic survey with two (2) foot contour intervals with slope determination made between each successive interval. The accuracy of the slope analysis shall be certified by an architect, engineer, landscape architect, or surveyor.

(B) To determine the practicality of providing accessibility to planned multifamily dwellings based on the topography or the existing natural terrain, the minimum percentage of ground floor units to be made accessible should equal the percentage of the total building area (not including flood plains, wetlands, or other restricted use areas) of the undisturbed site that has an existing natural grade of less than ten percent (10%) slope.

(C) In addition to the percentage established in paragraph (B), all ground floor units in a building, or ground floor units served by a particular entrance, shall be made accessible if the entrance to the units is on an accessible route, defined as a walkway with a slope between the planned entrance and a pedestrian or vehicular arrival point, that is no greater than eight and thirty-three hundredths percent (8.33%).

(b) **Site impracticality due to unusual characteristics.** Unusual characteristics include sites located in a federally-designated flood plain or coastal high-hazard area and sites subject to other similar requirements of law, rule, regulation, or ordinance that the lowest floor or the lowest structural member of the lowest floor must be raised to a specified level at or above the base flood elevation. An accessible route to a building entrance is impractical due to unusual characteristics of the site when:

(i) the unusual site characteristics result in a difference in finished grade elevation exceeding thirty (30) inches and ten percent (10%) measured between an

## Proposed Rules

entrance and all vehicular or pedestrian arrival points within fifty (50) feet of the planned entrance; or  
 (ii) if there are no vehicular or pedestrian arrival points within fifty (50) feet of the planned entrance, the unusual characteristics result in a difference in finished grade elevation exceeding thirty (30) inches and ten percent (10%) measured between an entrance and the closest vehicular or pedestrian arrival point.

(3) Exceptions to site impracticality. Regardless of site considerations described in paragraphs (1) and (2), an accessible entrance on an accessible route is practical when:

(a) there is an elevator connecting the parking area with the dwelling units on a ground floor, (in this case, those dwelling units on the ground floor served by an elevator, and at least one (1) of each type of public and common use areas, would be subject to this part.) however:

(i) where a building elevator is provided as a means of creating an accessible route to dwelling units on a ground floor, the building is not considered an elevator building for purposes of this part; hence, only the ground floor dwelling units would be covered; and  
 (ii) if the building elevator is provided as a means of access to dwelling units other than dwelling units on a ground floor, then the building is an elevator building, which is a covered multifamily dwelling and the

elevator in that building must provide accessibility to all dwelling units in the building, regardless of the slope of the natural terrain; or

(b) an elevated walkway is planned between a building entrance and a vehicular or pedestrian arrival point and the planned walkway has a slope no greater than ten percent (10%).

(4) Accessible Entrance. An entrance that complies with Section 4.14 of CABO/ANSI A117.1 1992, complies with section 3.0(a).

(5) Accessible Route. An accessible route that complies with CABO/ANSI A117.1 1992 will meet section 3.0(a). If the slope of the finished grade between covered dwellings and a public or common use facility (including parking) exceeds eight and thirty-three hundredths percent (8.33%) or where other physical barriers (natural or manmade) or legal restrictions, all of which are outside the control of the owner, prevent the installation of an accessible pedestrian route, an acceptable alternative is to provide access via a vehicular route, so long as necessary site provisions such as parking spaces and curb ramps are provided at the public or common use facility.

### Requirement 2. Accessible Public and Common Areas.

The following chart identifies the public and common areas that shall be made accessible, cites the appropriate section of the CABO/ANSI A117.1 1992, and describes the appropriate application of the specifications:

### BASIC COMPONENTS FOR ACCESSIBLE PUBLIC AND COMMON AREAS OR FACILITIES CABO/ANSI A117.1-1992

Accessible Element or Space	Section	Application
1. Accessible route(s)	4.3	Within boundary of the site: (a) from accessible parking spaces, accessible passenger loading zones, and streets or sidewalks to accessible building entrances. (b) connecting accessible buildings, facilities, elements, and spaces that are on the same site. (c) connecting accessible building or facility entrances with accessible spaces and elements within the building or facility, including adaptable dwelling units. (d) where site or legal constraints prevent a route accessible to wheelchair users between covered multifamily dwellings and public or common-use facilities elsewhere on the site.
2. Protruding objects	4.4	Accessible routes or maneuvering space including, but not limited to, halls, corridors, passageways, or aisles.
3. Ground and floor surface	4.5	Accessible routes, rooms, and spaces, including floors, surface treatments walks, ramps, stairs, and curb ramps.
4. Parking and passenger-loading zones	4.6	See IC 5-16-9.
5. Curb ramps	4.7	Accessible routes crossing curbs.
6. Ramps	4.8	Accessible routes with slopes greater than 1:20.
7. Stairs	4.9	Stairs on accessible routes connecting levels not connected by an elevator.
8. Elevator	4.10	If provided.

9. Platform lift	4.11	May be used in lieu of an elevator or ramp under certain conditions.
10. Drinking fountains and water coolers	4.15	Fifty percent (50%) of fountains and water coolers on each floor, or at least one (1), if provided, in the facility or at the site.
11. Toilet rooms and bathing facilities (including water closets, toilet rooms and stalls, urinals, lavatories and mirrors, bathtubs, shower stalls, and sinks)	4.22	Where provided in public-use and common-use facilities, at least one (1) of each fixture provided per room.
12. Common-use spaces and facilities (swimming pools and playgrounds, entrances, rental offices, lobbies, elevators, mailbox areas, lounges, halls and corridors, and similar spaces)	4.1 through 4.28	If provided in the facility or at the site.

**Requirement 3. Usable Doors.**

Section 3.0(c)(2) applies to doors that are part of an accessible route in the public and common areas of multi-family dwellings and to doors into and within individual dwelling units.

(1) On accessible routes in public and common use areas, and for primary entry doors to covered units, doors complying with Section 4.13 of CABO/ANSI A117.1 1992 will comply with this requirement.

(2) Within individual dwelling units, doors intended for user passage through the unit which have a clear opening of at least thirty-two (32) inches nominal width when the door is open ninety (90) degrees, measured between the face of the door and the stop, will conform to section 3.0(c)(2) (see Fig. 1(a), 1(b), and 1(c)). Openings more than twenty-four (24) inches in depth are not considered doorways (see Fig. 1(d)).

**NOTE:** A thirty-four (34) inch door, hung in the standard manner, provides an acceptable, nominal thirty-two (32) inch clear opening. This door can be adapted to provide a wider opening by using offset hinges or by removing lower portions of the door stop, or both. Pocket or sliding doors are acceptable doors in covered dwelling units and have the added advantage of not impinging on clear floor space in small rooms. The nominal thirty-two (32) inch clear opening provided by a standard six (6) foot sliding patio door assembly is acceptable.

**Requirement 4. Accessible route into and through the covered dwelling unit.**

Accessible routes into and through dwelling units will conform to section 3.0(c)(3)(i) if the requirements in this section are met.

(1) A minimum clear width of thirty-six (36) inches is provided.

(2) In single-story dwelling units, changes in levels within the dwelling unit with heights between one-fourth (1/4) inch and one-half (1/2) inch are beveled with a slope no greater than 1:2. Except for design features, such as a loft or an area on a different level within a room, for example, a sunken living room, changes in levels greater than one-half (1/2) inch are ramped or have other means of access.

Where a single-story dwelling unit has special design features, all portions of the single-story unit, except the loft or the sunken or raised area, are on an accessible route; and

(a) In single-story dwelling units with lofts, all spaces other than the loft are on an accessible route.

(b) Design features such as sunken or raised functional areas do not interrupt the accessible route through the remainder of the dwelling unit.

(3) In multistory dwelling units in buildings with elevators, the story of the unit that is served by the building elevator:

(a) is the primary entry to the unit;

(b) complies with Requirements 2 through 7 with respect to the rooms located on the entry/accessible floor; and

(c) contains a bathroom or powder room which complies with Requirement 7. (NOTE: Multistory dwelling units in nonelevator buildings are not covered dwelling units because, in such cases, there is no ground floor unit.)

(4) Except as provided in paragraphs (5) and (6), thresholds at exterior doors, including sliding door tracks, are no higher than three-fourths (3/4) inch. Thresholds and changes in level at these locations are beveled with a slope no greater than 1:2.

(5) Exterior deck, patio, or balcony surfaces are not more than one-half (1/2) inch below the floor level of the interior of the dwelling unit, unless they are constructed of impervious material such as concrete, brick, or flagstone. In such case, the surface is not more than four (4) inches below the floor level of the interior of the dwelling unit.

(6) At the primary entry door to dwelling units with direct exterior access, outside landing surfaces constructed of impervious materials, such as concrete, brick, or flagstone, are not more than one-half (1/2) inch below the floor level of the interior of the dwelling unit. The finished surface of this area that is located immediately outside the entry may be sloped, up to one-eighth (1/8) inch per foot, for drainage.

**Requirement 5. Light Switches, Electrical Outlets, Thermo-**

stats, and Other Environmental Controls in Accessible Locations.

Light switches, electrical outlets, thermostats, and other environmental controls will conform to section 3.0(c)(3)(ii) if operable parts of the controls are located no higher than forty-eight (48) inches, and no lower than fifteen (15) inches, above the floor. If the reach is over an obstruction, for example, an overhanging shelf, between twenty (20) and twenty-five (25) inches in depth, the maximum height is reduced to forty-four (44) inches for forward approach; or forty-six (46) inches for side approach, provided the obstruction, for example, a kitchen base cabinet, is no more than twenty-four (24) inches in depth. Obstructions shall not exceed more than twenty-five (25) inches from the wall beneath a control (see Fig. 2).

### Requirement 6. Reinforced Walls for Grab Bars.

Reinforced bathroom walls to allow later installation of grab bars around the toilet, tub, shower stall, and shower seat, where such facilities are provided, will conform to section 3.0(c)(3)(iii) (see Figs. 3, 4, and 5). Where the toilet is not placed adjacent to a side wall, the bathroom will comply if provision is made for installation of floor mounted foldaway or similar alternative grab bars. Where the powder room is the only toilet facility located on an accessible level of a multistory dwelling unit, it must comply with this requirement for reinforced walls for grab bars.

NOTE: Installation of bathtubs or showers is not limited by the illustrative figures, such as reinforced areas, for installation of floor-mounted grab bars.

Reinforcement for grab bars may be provided in a variety of ways, for example, by plywood or wood blocking, so long as the necessary reinforcement is placed so as to permit later installation of appropriate grab bars.

### Requirement 7. Usable Kitchens and Bathrooms.

(1) Usable kitchens. Usable kitchens will conform to section 3.0(c)(3)(iv) if:

(a) a clear floor space at least thirty (30) inches by forty-eight (48) inches that allows a parallel approach by a person in a wheelchair is provided at the range or cooktop and sink, and either a parallel or forward approach is provided at oven, dishwasher, refrigerator/freezers, or trash compactor (see Fig. 6);

(b) clearance between counters and all opposing base cabinets, countertops, appliances, or walls is at least forty (40) inches; and

(c) in U-shaped kitchens with sink or range or cooktop at the base of the "U", a sixty (60) inch turning radius is provided to allow parallel approach, or base cabinets are removable at that location to allow knee space for a forward approach.

(2) Usable bathrooms. To meet the requirements of section 3.0(c)(3)(iv), either all bathrooms in the dwelling unit shall comply with the provisions of paragraph (a), or at least one (1) bathroom in the dwelling unit complies with the provisions of paragraph (b), and all other

bathrooms and powder rooms within the dwelling unit must be on an accessible route with usable entry doors in accordance with Requirements 3 and 4.

However, in multistory dwelling units, only those bathrooms on the accessible level are subject to the requirements of section 3.0(c)(3)(iv). Where a powder room is the only facility provided on the accessible level of a multistory dwelling unit, the powder room shall comply with provisions of paragraph (a) or (b). Powder rooms that are subject to the requirements of section 3.0(c)(3)(iv) shall have reinforcements for grab bars as provided in Requirement 6.

(a) Bathrooms that have reinforced walls for grab bars (see Requirement 6) shall conform to section 3.0(c)(3)(iv) if:

(i) Sufficient maneuvering space is provided within the bathroom for a person using a wheelchair or other mobility aid to enter and close the door, use the fixtures, reopen the door, and exit. Doors may swing into the clear floor space provided at any fixture if the maneuvering space is provided. Maneuvering spaces may include any kneespace or toespace available below bathroom fixtures.

(ii) Clear floor space is provided at fixtures as shown in Fig. 7(a), 7(b), 7(c), and 7(d). Clear floor space at fixtures may overlap.

(iii) If the shower stall is the only bathing facility provided in the covered dwelling unit, the shower stall shall measure at least thirty-six (36) inches by thirty-six (36) inches.

NOTE: Cabinets under lavatories are acceptable provided the bathroom has space to allow a parallel approach by a person in a wheelchair; if parallel approach is not possible within the space, any cabinets provided would have to be removable to afford the necessary knee clearance for forward approach.

(b) Bathrooms that have reinforced walls for grab bars (see Requirement 6) will conform to section 3.0(c)(3)(iv) if:

(i) Where the door swings into the bathroom, there is a clear space (approximately, two (2) feet six (6) inches by four (4) feet) within the room to position a wheelchair or other mobility aid clear of the path of the door as it is closed and to permit use of fixtures. This clear space can include any kneespace and toespace available below bathroom fixtures.

(ii) Where the door swings out, a clear space is provided within the bathroom for a person using a wheelchair or other mobility aid to position the wheelchair such that the person is allowed use of fixtures. There also shall be clear space to allow persons using wheelchairs to reopen the door to exit.

(iii) When both tub and shower fixtures are provided in the bathroom, at least one (1) is made accessible. When two (2) or more lavatories in a bathroom are provided, at least one (1) is made accessible.



(iv) Toilets are located within bathrooms in a manner that permits a grab bar to be installed on one (1) side of the fixture. In locations where toilets are adjacent to walls or bathtubs, the centerline of the fixture is a minimum of one (1) foot six (6) inches from the obstacle. The other (nongrab bar) side of the toilet fixture is a minimum of one (1) foot three (3) inches from the finished surface of adjoining walls, vanities, or the edge of a lavatory (see Fig. 7(a)).

(v) Vanities and lavatories are installed with the centerline of the fixture a minimum of one (1) foot three (3) inches horizontally from an adjoining wall or fixture. The top of the fixture rim is a maximum height of two (2) feet ten (10) inches above the finished floor. If kneespace is provided below the vanity, the bottom of the apron is at least two (2) feet three (3) inches above the floor. If provided, full kneespace (for front approach) is at least one (1) foot five (5) inches deep (see Fig. 7(c)).

(vi) Bathtubs and tub/showers located in the bathroom provide a clear access aisle adjacent to the lavatory that is at least two (2) feet six (6) inches wide and extends for a length of four (4) feet (measured from the head of the bathtub) (see Fig. 8).

(vii) Stall showers in the bathroom may be of any size or configuration. A minimum clear floor space two (2) feet six (6) inches wide by four (4) feet shall be available outside the stall (see Fig. 7(d)). If the shower stall is the only bathing facility provided in the covered dwelling unit, or on the accessible level of a covered multistory unit, and measures a nominal thirty-six (36) inches by thirty-six (36) inches or smaller, the shower stall must have reinforcement to allow for installation of an optional hung bench seat.

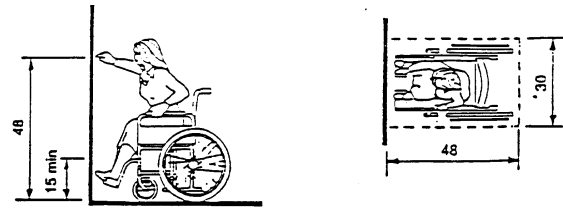

(a) Forward Reach Limit

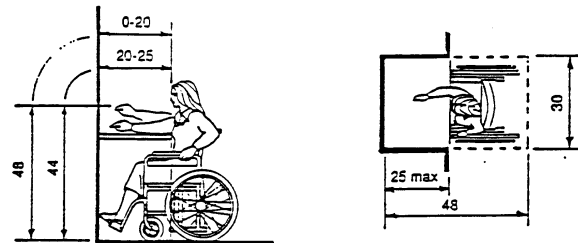

NOTE: Clear knee space should be as deep as the reach distance.

(b) Maximum Forward Reach Over an Obstruction

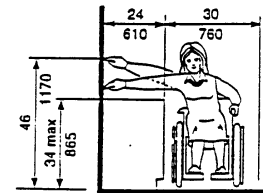

(c) Maximum Side Reach Over Obstruction

Fig. 2 Reach Ranges

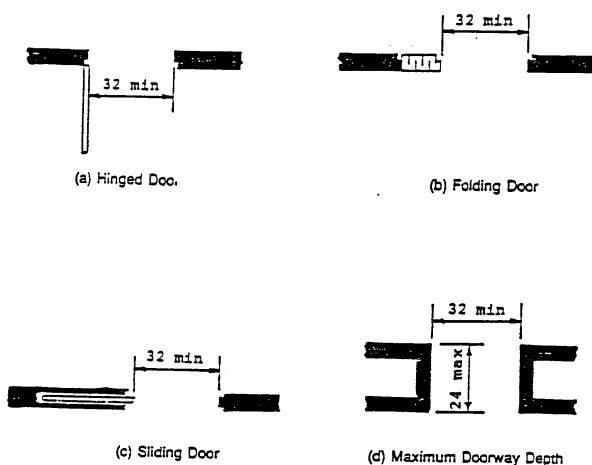
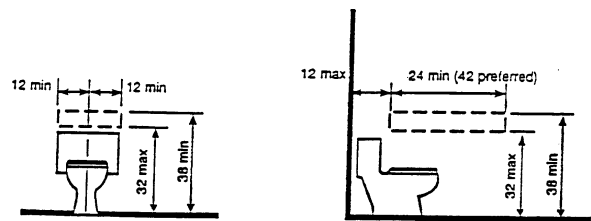

Fig. 1 Clear Doorway Width and Depth



Reinforced Areas for Installation of Grab Bars

Fig. 3 Water Closets in Adaptable Bathrooms

# Proposed Rules

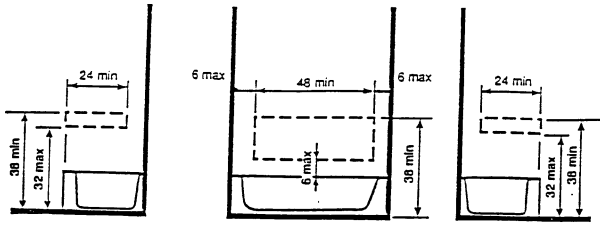

Fig. 4 Location of Grab Bar Reinforcements for Adaptable Bathtubs

NOTE: The areas outlined in dashed lines represent locations for future installation of grab bars for typical fixture configurations.

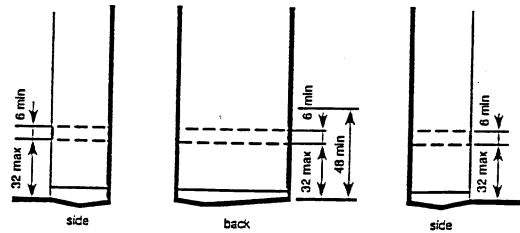

Fig. 5 Location of Grab Bar Reinforcements for Adaptable Showers

NOTE: The areas outlined in dashed lines represent locations for future installation of grab bars.

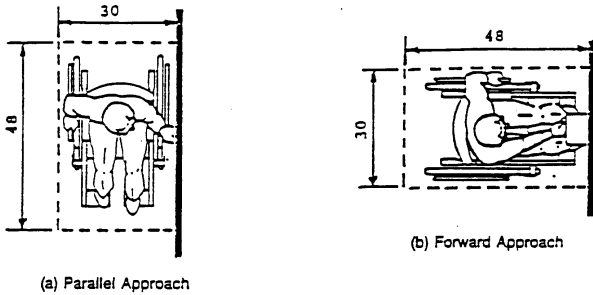
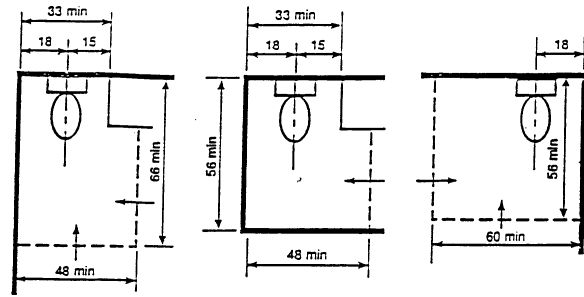
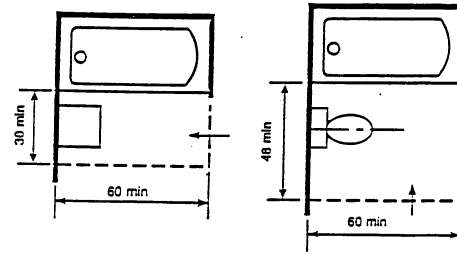

Fig. 6 Minimum Clear Floor Space for Wheelchairs



(a) Clear Floor Space for Water Closets



(b) Clear Floor Space at Bathtubs

Fig. 7 Clear Floor Space for Adaptable Bathrooms

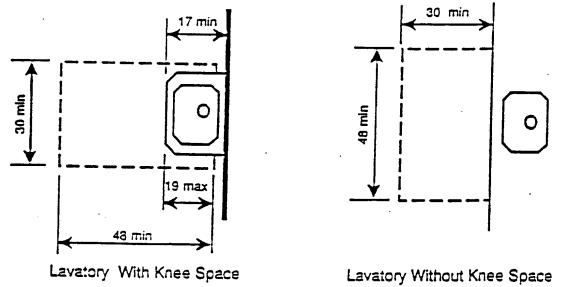

(c) Clear Floor Space at Lavatories

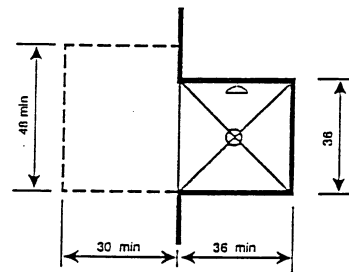

(d) Clear Floor Space at Shower

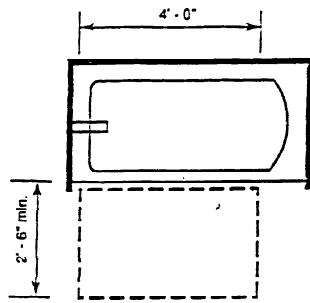

Fig. 8 Alternative Specification – Clear Floor Space at Bathtub

**Subpart B CABO/ANSI A117.1 - 1992**

That certain document being titled as the American National Standard, Accessible and Usable Buildings and Facilities CABO/ANSI A117.1-1992, published by the Council of American Building Officials, 5203 Leesburg Pike, #708, Falls Church, Virginia 22041, is hereby adopted by reference, as if fully set out in this rule, same and except the following revisions:

Delete section 1 without substitution.

Delete section 2 without substitution.

Delete subsection 3.3 and substitute as follows: ASME/ANSI A17.1 means the Indiana Safety Code for Elevators, Escalators, Manlifts, and Hoists (675 IAC 21).

Change the following definitions in section 3.2 to read as follows: (a) "ADMINISTRATIVE AUTHORITY" means the state building commissioner or officer of a local unit of government empowered by law to administer and enforce the rules of the fire prevention and building safety commission.

(b) "TEMPORARY" means a temporary structure erected as defined in the General Administrative Rules (675 IAC 12-6).

Delete subsection 4.6.2 Parking Spaces and substitute to read as follows: Parking shall comply with IC 5-16-9.

Change subsection 4.8.2 to read as follows: Ramps in new construction shall have a slope not steeper than 1:12. The rise for any ramp run shall be thirty (30) inches (seven hundred sixty (760) millimeters) maximum (see Fig. B4.8.2).

Delete Table 4.8.2 without substitution.

Delete subsection 4.10.2.

Change subsection 4.11 to read as follows: Wheelchair lifts, if provided, shall comply with the Indiana Safety Code for Elevators, Escalators, Manlifts, and Hoists (675 IAC 21).

Delete the first sentence of subsection 4.13.11.

Delete in subsection 4.13.12 "ANSI/BHMA A156.10" and substitute Chapter 10 of the Indiana Building Code (675 IAC 13).

Delete in subsection 4.13.13 "ANSI/BHMA A156.19" and substitute Chapter 10 of the Indiana Building Code.

Delete subsection 4.23 without substitution.

Change subsection 4.26.1 to read as follows: Alarms required by this code shall conform to subsection 4.26.

Delete subsection 4.30 without substitution.

Delete subsection 4.31 without substitution.

Delete subsection 4.32 without substitution.

Change subsection 4.33.4 to read as follows: Accessible kitchens shall comply with the requirements of section 4.33.4.

Delete subsections 4.33.4.6, 4.33.4.7, 4.33.4.8, 4.33.4.9, 4.33.4.10, 4.33.5, 4.33.5.1, and 4.33.5.2 without substitution.

Appendix A is not adopted and is for information purposes only. (Fire Prevention and Building Safety Commission; 675 IAC 13-2.4-111)

**675 IAC 13-2.4-112 Section 1201.1; scope**

Authority: IC 22-13-2-2; IC 22-13-2-13

Affected: IC 22-12; IC 22-13; IC 22-14; IC 22-15; IC 36-7

Sec. 112. Delete Section 1201.1 Scope and substitute to read as follows: The provisions of this chapter shall govern ventilation, temperature control, lighting, yards and courts, room dimensions and surrounding materials associated with the interior spaces of buildings. (Fire Prevention and Building Safety Commission; 675 IAC 13-2.4-112)

**675 IAC 13-2.4-113 Section 1202.3.2; ventilation openings**

Authority: IC 22-13-2-2; IC 22-13-2-13

Affected: IC 22-12; IC 22-13; IC 22-14; IC 22-15; IC 36-7

Sec. 113. Change Section 1202.3.2 Exception as follows: (1) Change Exception 1 to read as follows: Ventilation openings to the outdoors are not required if ventilation openings to the interior are provided.

(2) Delete Exception 5 and substitute: See local ordinance. (Fire Prevention and Building Safety Commission; 675 IAC 13-2.4-113)

**675 IAC 13-2.4-114 Section 1203.1; equipment systems**

Authority: IC 22-13-2-2; IC 22-13-2-13

Affected: IC 22-12; IC 22-13; IC 22-14; IC 22-15; IC 36-7

Sec. 114. Change the first paragraph of Section 1203.1 Equipment and systems to read as follows: Interior spaces intended for human occupancy shall be provided with active or passive space-heating systems capable of maintaining a minimum indoor temperature of 68° F (20° C) at a point 3 feet (914 mm) above the floor on the design heating day, based on the exterior design condition as stated in the Indiana Energy Conservation Code (675 IAC 19). Exception: Interior spaces where the primary purpose is not associated with human comfort. (Fire Prevention and Building Safety Commission; 675 IAC 13-2.4-114)

**675 IAC 13-2.4-115 Section 1206; sound transmission**

Authority: IC 22-13-2-2; IC 22-13-2-13

Affected: IC 22-12; IC 22-13; IC 22-14; IC 22-15; IC 36-7

Sec. 115. Delete Section 1206 Sound transmission. (Fire Prevention and Building Safety Commission; 675 IAC 13-2.4-115)

## Proposed Rules

### 675 IAC 13-2.4-116 Section 1207.2; minimum ceiling heights

Authority: IC 22-13-2-2; IC 22-13-2-13  
Affected: IC 22-12; IC 22-13; IC 22-14; IC 22-15; IC 36-7

**Sec. 116. Delete Exceptions 1 and 2 in Section 1207.2 Minimum ceiling heights and substitute:** See Section 101.2. (*Fire Prevention and Building Safety Commission; 675 IAC 13-2.4-116*)

### 675 IAC 13-2.4-117 Section 1208.1; crawl spaces

Authority: IC 22-13-2-2; IC 22-13-2-13  
Affected: IC 22-12; IC 22-13; IC 22-14; IC 22-15; IC 36-7

**Sec. 117. Change Section 1208.1 Crawl spaces to read as follows:** Crawl spaces shall be provided with a minimum of one access opening not less than 16 inches by 30 inches (508 mm by 762 mm). (*Fire Prevention and Building Safety Commission; 675 IAC 13-2.4-117*)

### 675 IAC 13-2.4-118 Section 1208.2; attic spaces

Authority: IC 22-13-2-2; IC 22-13-2-13  
Affected: IC 22-12; IC 22-13; IC 22-14; IC 22-15; IC 36-7

**Sec. 118. Change Section 1208.2 Attic spaces to read as follows:** An opening not less than 20 inches by 40 inches (508 mm by 1,016 mm) shall be provided to any attic area having a clear height of over 30 inches (762 mm). A 30-inch (762 mm) minimum clear headroom in the attic space shall be provided at or above the access opening. When the access opening penetrates fire-resistive construction, the access opening closure shall provide the fire-resistive construction as required for the fire-resistive construction that is penetrated for the opening, and may be manufactured or field assembled, and shall be tight fitting. (*Fire Prevention and Building Safety Commission; 675 IAC 13-2.4-118*)

### 675 IAC 13-2.4-119 Table 1505.1; minimum roof covering classification for types of construction

Authority: IC 22-13-2-2; IC 22-13-2-13  
Affected: IC 22-12; IC 22-13; IC 22-14; IC 22-15; IC 36-7

**Sec. 119. Delete in TABLE 1505.1 MINIMUM ROOF COVERING CLASSIFICATION FOR TYPES OF CONSTRUCTION, Footnote a.** (*Fire Prevention and Building Safety Commission; 675 IAC 13-2.4-119*)

### 675 IAC 13-2.4-120 Section 1510.1; general

Authority: IC 22-13-2-2; IC 22-13-2-13  
Affected: IC 22-12; IC 22-13; IC 22-14; IC 22-15; IC 36-7

**Sec. 120. Delete the second sentence of Section 1510.1 General and substitute as follows:** For roof repairs see local ordinance. (*Fire Prevention and Building Safety Commission; 675 IAC 13-2.4-120*)

### 675 IAC 13-2.4-121 Section 1603; construction documents

Authority: IC 22-13-2-2; IC 22-13-2-13  
Affected: IC 22-12; IC 22-13; IC 22-14; IC 22-15; IC 36-7

**Sec. 121. Delete Section 1603 Construction documents and substitute as follows:** See the General Administrative Rules (675 IAC 12-6), Industrialized Building Systems (675 IAC 15) and local ordinance. (*Fire Prevention and Building Safety Commission; 675 IAC 13-2.4-121*)

### 675 IAC 13-2.4-122 Section 1604.6; in-situ load tests

Authority: IC 22-13-2-2; IC 22-13-2-13  
Affected: IC 22-12; IC 22-13; IC 22-14; IC 22-15; IC 36-7

**Sec. 122. Delete the last sentence of Section 1604.6 In-situ load tests.** (*Fire Prevention and Building Safety Commission; 675 IAC 13-2.4-122*)

### 675 IAC 13-2.4-123 Table 1607.1 minimum uniformly distributed live loads and minimum concentrated live loads

Authority: IC 22-13-2-2; IC 22-13-2-13  
Affected: IC 22-12; IC 22-13; IC 22-14; IC 22-15; IC 36-7

**Sec. 123. Change in TABLE 1607.1 MINIMUM UNIFORMLY DISTRIBUTED LIVE LOADS AND MINIMUM CONCENTRATED LIVE LOADS, Footnote g to read as follows:** g. Where snow loads occur that are in excess of the design conditions, the structure shall be designed to support the loads due to the increased loads caused by drift buildup or a greater snow design determined by the registered design professional or the owner if a registered design professional is not required by the General Administrative Rules (675 IAC 12-6) or the rules for Industrialized Building Systems (675 IAC 15). See Section 1608. For special-purpose roofs, see Section 1607.11.2.2. (*Fire Prevention and Building Safety Commission; 675 IAC 13-2.4-123*)

### 675 IAC 13-2.4-124 Section 1607.7.1; handrail guards

Authority: IC 22-13-2-2; IC 22-13-2-13  
Affected: IC 22-12; IC 22-13; IC 22-14; IC 22-15; IC 36-7

**Sec. 124. Delete Exception 1 in Section 1607.7.1 Handrails and guards and substitute:** See Section 101.2. (*Fire Prevention and Building Safety Commission; 675 IAC 13-2.4-124*)

### 675 IAC 13-2.4-125 Section 1608.2; ground snow loads

Authority: IC 22-13-2-2; IC 22-13-2-13  
Affected: IC 22-12; IC 22-13; IC 22-14; IC 22-15; IC 36-7

**Sec. 125. Change Section 1608.2 Ground snow loads to read as follows:** The ground snow loads to be used in determining the snow loads for roofs are given in Figure 1608.2. Site-specific case studies shall be made in areas designated CS in Figure 1608.2. Ground snow loads for all sites within the CS areas shall be approved. Ground snow load determination for such sites shall be based on an extreme value statistical analysis of data available in the vicinity of the site using a value with a 2-percent annual probability of being exceeded (50-year mean recurrence

interval). Counties that have more than one ground snow load as given in Figure 1608.2 shall apply the most restrictive ground snow load throughout the entire county. *(Fire Prevention and Building Safety Commission; 675 IAC 13-2.4-125)*

**675 IAC 13-2.4-126 Section 1609.1.4; protection of openings**

Authority: IC 22-13-2-2; IC 22-13-2-13  
Affected: IC 22-12; IC 22-13; IC 22-14; IC 22-15; IC 36-7

**Sec. 126. Delete Section 1609.1.4 Protection of openings, and TABLE 1609.1.4 WINDBORNE DEBRIS PROTECTION FASTENING SCHEDULE FOR WOOD STRUCTURAL PANELS.** *(Fire Prevention and Building Safety Commission; 675 IAC 13-2.4-126)*

**675 IAC 13-2.4-127 Section 1611.1; design rain loads**

Authority: IC 22-13-2-2; IC 22-13-2-13  
Affected: IC 22-12; IC 22-13; IC 22-14; IC 22-15; IC 36-7

**Sec. 127. Add to the end of Section 1611.1 the following: See the Indiana Plumbing Code (675 IAC 16) for other roof drainage requirements.** *(Fire Prevention and Building Safety Commission; 675 IAC 13-2.4-127)*

**675 IAC 13-2.4-128 Section 1611.3; control drainage**

Authority: IC 22-13-2-2; IC 22-13-2-13  
Affected: IC 22-12; IC 22-13; IC 22-14; IC 22-15; IC 36-7

**Sec. 128. Add a second paragraph to Section 1611.3 Control drainage to read: See the Indiana Plumbing Code (675 IAC 16) for other roof drainage requirements.** *(Fire Prevention and Building Safety Commission; 675 IAC 13-2.4-128)*

**675 IAC 13-2.4-129 Section 1612; flood loads**

Authority: IC 22-13-2-2; IC 22-13-2-13  
Affected: IC 22-12; IC 22-13; IC 22-14; IC 22-15; IC 36-7

**Sec. 129. Delete Section 1612 Flood loads and substitute: See local Ordinance.** *(Fire Prevention and Building Safety Commission; 675 IAC 13-2.4-129)*

**675 IAC 13-2.4-130 Section 1614.4; quality assurance**

Authority: IC 22-13-2-2; IC 22-13-2-13  
Affected: IC 22-12; IC 22-13; IC 22-14; IC 22-15; IC 36-7

**Sec. 130. Delete Section 1614.4 Quality assurance.** *(Fire Prevention and Building Safety Commission; 675 IAC 13-2.4-130)*

**675 IAC 13-2.4-131 Section 1615.1.3: Table 1615.1.3**

Authority: IC 22-13-2-2; IC 22-13-2-13  
Affected: IC 22-12; IC 22-13; IC 22-14; IC 22-15; IC 36-7

**Sec. 131. Change Section 1615.1.3 as follows:**  
**(1) Add an Exception to the end of Section 1615.1.3 to read as follows:**  
Exception: The maximum values of SDS and SD1 listed in TABLE 1615.1.3.  
**(2) Add TABLE 1615.1.3 MAXIMUM VALUES FOR**

**SDS AND SD1 to the end of Section 1615.1.3 to read as follows:**

**TABLE 1615.1.3 - MAXIMUM VALUES FOR SDS AND SD1**

Site Class	SDS	SD1
A	0.30	0.12
B	0.38	0.15
C	0.45	0.25
D	0.55	0.32
E	0.75	0.50
F	Note 1	Note 1

**Note 1: Site-specific geotechnical investigation and dynamic site response analyses shall be performed to determine appropriate values.**

*(Fire Prevention and Building Safety Commission; 675 IAC 13-2.4-131)*

**675 IAC 13-2.4-132 Section 1616.2.2; seismic use Group II**

Authority: IC 22-13-2-2; IC 22-13-2-13  
Affected: IC 22-12; IC 22-13; IC 22-14; IC 22-15; IC 36-7

**Sec. 132. Delete in Section 1616.2.2 Seismic use Group II the words “the building official” and substitute “local ordinance”.** *(Fire Prevention and Building Safety Commission; 675 IAC 13-2.4-132)*

**675 IAC 13-2.4-133 Section 1616.2.3; seismic use Group III**

Authority: IC 22-13-2-2; IC 22-13-2-13  
Affected: IC 22-12; IC 22-13; IC 22-14; IC 22-15; IC 36-7

**Sec. 133. Change Section 1616.2.3 Seismic use Group III as follows:**

**(1) Delete the words “, or as designated by the building official”.**

**(2) Add an Exception to the end of Section 1616.3 to read as follows:**

**EXCEPTION: The seismic design category need not exceed Seismic Design Category C for buildings and structures in Seismic Use Groups I and II and Seismic Design Category D for Class 1 buildings and structures in Seismic Use Group III.**

*(Fire Prevention and Building Safety Commission; 675 IAC 13-2.4-133)*

**675 IAC 13-2.4-134 Section 1618.10.3.2; design review**

Authority: IC 22-13-2-2; IC 22-13-2-13  
Affected: IC 22-12; IC 22-13; IC 22-14; IC 22-15; IC 36-7

**Sec. 134. Delete Section 1618.10.3.2 Design review.** *(Fire Prevention and Building Safety Commission; 675 IAC 13-2.4-134)*

**675 IAC 13-2.4-135 Section 1621.1.8; quality assurance; special inspection and testing**

Authority: IC 22-13-2-2; IC 22-13-2-13  
Affected: IC 22-12; IC 22-13; IC 22-14; IC 22-15; IC 36-7

## Proposed Rules

**Sec. 135. Delete Section 1621.1.8 Quality assurance; special inspection and testing.** (*Fire Prevention and Building Safety Commission; 675 IAC 13-2.4-135*)

**675 IAC 13-2.4-136 Section 1621.2.6.1; special access floors**

Authority: IC 22-13-2-2; IC 22-13-2-13  
Affected: IC 22-12; IC 22-13; IC 22-14; IC 22-15; IC 36-7

**Sec. 136. Change the last sentence of item 1 of Section 1621.2.6.1 Special access floors to read as follows: Design load capacities comply with approved design standards and/or approved test results.** (*Fire Prevention and Building Safety Commission; 675 IAC 13-2.4-136*)

**675 IAC 13-2.4-137 Section 1621.2.7; partitions**

Authority: IC 22-13-2-2; IC 22-13-2-13  
Affected: IC 22-12; IC 22-13; IC 22-14; IC 22-15; IC 36-7

**Sec. 137. Change Section 1621.2.7 Partitions as follows: In the Exception, change section reference from "1622.3.4" to "1607.13".** (*Fire Prevention and Building Safety Commission; 675 IAC 13-2.4-137*)

**675 IAC 13-2.4-138 Section 1621.2.8; steel storage racks**

Authority: IC 22-13-2-2; IC 22-13-2-13  
Affected: IC 22-12; IC 22-13; IC 22-14; IC 22-15; IC 36-7

**Sec. 138. Delete Section 1621.2.8 Steel storage racks and substitute as follows: Steel storage racks that are part of the structural system of a Class 1 structure shall comply with this code.** (*Fire Prevention and Building Safety Commission; 675 IAC 13-2.4-138*)

**675 IAC 13-2.4-139 Section 1621.3.8; storage tanks**

Authority: IC 22-13-2-2; IC 22-13-2-13  
Affected: IC 22-12; IC 22-13; IC 22-14; IC 22-15; IC 36-7

**Sec. 139. Change Section 1621.3.8 Storage tanks to read as follows: Storage tanks within the scope of Section 101.2 shall be designed to meet the general requirements of Sections 1622.1 and 1622.2 and the specific requirements of Section 1622.4.3.** (*Fire Prevention and Building Safety Commission; 675 IAC 13-2.4-139*)

**675 IAC 13-2.4-140 Section 1621.3.10.2; other piping systems**

Authority: IC 22-13-2-2; IC 22-13-2-13  
Affected: IC 22-12; IC 22-13; IC 22-14; IC 22-15; IC 36-7

**Sec. 140. Change the first sentence of Section 1621.3.10.2 Other piping systems to read as follows: The following documents shall be used for the seismic design of the respective systems when the systems are within the scope of Section 101.2.** (*Fire Prevention and Building Safety Commission; 675 IAC 13-2.4-140*)

**675 IAC 13-2.4-141 Section 1621.3.10.2.1; support and attachments for other piping**

Authority: IC 22-13-2-2; IC 22-13-2-13  
Affected: IC 22-12; IC 22-13; IC 22-14; IC 22-15; IC 36-7

**Sec. 141. Add the third line of Section 1621.3.10.2.1 Supports and attachments for other piping, between the words "piping" and "shall" the words "that are within the scope of Section 101.2".** (*Fire Prevention and Building Safety Commission; 675 IAC 13-2.4-141*)

**675 IAC 13-2.4-142 Section 1621.3.11.1; ASME boilers and pressure vessels**

Authority: IC 22-13-2-2; IC 22-13-2-13  
Affected: IC 22-12; IC 22-13; IC 22-14; IC 22-15; IC 36-7

**Sec. 142. Delete Section 1621.3.11.1 ASME Boilers and Pressure Vessels.** (*Fire Prevention and Building Safety Commission; 675 IAC 13-2.4-142*)

**675 IAC 13-2.4-143 Section 1621.3.12; mechanical equipment attachments**

Authority: IC 22-13-2-2; IC 22-13-2-13  
Affected: IC 22-12; IC 22-13; IC 22-14; IC 22-15; IC 36-7

**Sec. 143. Change the first sentence of Section 1621.3.12 Mechanical equipment attachments and supports to read as follows: Attachments and supports for mechanical equipment that are within the scope of Section 101.2 and not covered in the preceding sections shall be designed to meet the force and displacement requirements of Sections 1621.1.4 and 1621.1.5 and the additional requirements of this section.** (*Fire Prevention and Building Safety Commission; 675 IAC 13-2.4-143*)

**675 IAC 13-2.4-144 Section 1621.3.12.1; mechanical equipment**

Authority: IC 22-13-2-2; IC 22-13-2-13  
Affected: IC 22-12; IC 22-13; IC 22-14; IC 22-15; IC 36-7

**Sec. 144. Change the first paragraph of Section 1621.3.12.1 Mechanical equipment to read as follows: Mechanical equipment that is within the scope of Section 101.2 having an  $I_p$  greater than 1.0 shall meet the following requirements:**

1. For equipment components vulnerable to impact, equipment components constructed of nonductile materials, or in cases where material ductility is reduced (e.g., low temperature applications), seismic impact shall be prevented.

2. The design shall include the effect of loadings imposed on the equipment by attached utility or service lines due to differential motions of points of support from separate structures.

(*Fire Prevention and Building Safety Commission; 675 IAC 13-2.4-144*)

**675 IAC 13-2.4-145 Section 1621.3.12.2; attachments and support for mechanical equipment**

Authority: IC 22-13-2-2; IC 22-13-2-13  
 Affected: IC 22-12; IC 22-13; IC 22-14; IC 22-15; IC 36-7

**Sec. 145.** Change the first part of the first sentence up to the colon of Section 1621.3.12.2 Attachments and supports for mechanical equipment to read as follows: Attachments and supports for mechanical equipment that are within the scope of Section 101.2 shall meet the following requirements. (Fire Prevention and Building Safety Commission; 675 IAC 13-2.4-145)

**675 IAC 13-2.4-146 Section 1621.3.13; electrical equipment and support**

Authority: IC 22-13-2-2; IC 22-13-2-13  
 Affected: IC 22-12; IC 22-13; IC 22-14; IC 22-15; IC 36-7

**Sec. 146.** Change the first sentence of Section 1621.3.13 Electrical equipment attachments and support to read as follows: Attachments and supports for electrical equipment that are within the scope of Section 101.2 shall be designed to meet the force and displacement requirements of Sections 1621.1.4 and 1621.1.5 and the additional requirements of this section. (Fire Prevention and Building Safety Commission; 675 IAC 13-2.4-146)

**675 IAC 13-2.4-147 Section 1622.1; nonbuilding structures**

Authority: IC 22-13-2-2; IC 22-13-2-13  
 Affected: IC 22-12; IC 22-13; IC 22-14; IC 22-15; IC 36-7

**Sec. 147.** Change the first paragraph of Section 1622.1 Nonbuilding structures to read as follows: The requirements of this section apply to self-supporting structures that are within the scope of Section 101.2 that carry gravity loads that are not defined as buildings, vehicular or railroad bridges, nuclear power generation plants, offshore platforms, or dams. Where the building official has approved the use of specific industry standards for seismic design of nonbuilding structures, those standards shall be applicable within the limitations of the requirements of this section. (Fire Prevention and Building Safety Commission; 675 IAC 13-2.4-147)

**675 IAC 13-2.4-148 Section 1622.3.4; steel storage racks**

Authority: IC 22-13-2-2; IC 22-13-2-13  
 Affected: IC 22-12; IC 22-13; IC 22-14; IC 22-15; IC 36-7

**Sec. 148.** Delete Section 1622.3.4 Steel storage racks and substitute as follows: Storage racks that are an integral part of the structural system of a Class 1 structure shall comply with this code. (Fire Prevention and Building Safety Commission; 675 IAC 13-2.4-148)

**675 IAC 13-2.4-149 Section 1622.3.4.3; vertical distribution of seismic force**

Authority: IC 22-13-2-2; IC 22-13-2-13  
 Affected: IC 22-12; IC 22-13; IC 22-14; IC 22-15; IC 36-7

**Sec. 149.** Delete Section 1622.3.4.3 Vertical distribution of seismic forces. (Fire Prevention and Building Safety Commission; 675 IAC 13-2.4-149)

**675 IAC 13-2.4-150 Section 1622.3.4.4; seismic displacement**

Authority: IC 22-13-2-2; IC 22-13-2-13  
 Affected: IC 22-12; IC 22-13; IC 22-14; IC 22-15; IC 36-7

**Sec. 150.** Delete Section 1622.3.4.4 Seismic displacement. (Fire Prevention and Building Safety Commission; 675 IAC 13-2.4-150)

**675 IAC 13-2.4-151 Section 1622.3.6; structural towers for tanks and vessels**

Authority: IC 22-13-2-2; IC 22-13-2-13  
 Affected: IC 22-12; IC 22-13; IC 22-14; IC 22-15; IC 36-7

**Sec. 151.** Change the first sentence of Section 1622.3.6 Structural towers for tanks and vessels to read as follows: The seismic design of structural towers that support tanks and vessels where the tanks or vessels are within the scope of Section 101.2 shall meet the requirements of Section 1622.1.1. (Fire Prevention and Building Safety Commission; 675 IAC 13-2.4-151)

**675 IAC 13-2.4-152 Section 1622.4.2; earth-retaining structures**

Authority: IC 22-13-2-2; IC 22-13-2-13  
 Affected: IC 22-12; IC 22-13; IC 22-14; IC 22-15; IC 36-7

**Sec. 152.** Change the title of Section 1622.4.2 Earth-retaining structures to read: Earth-retaining structures that are within the scope of Section 101.2. (Fire Prevention and Building Safety Commission; 675 IAC 13-2.4-152)

**675 IAC 13-2.4-153 Section 1622.4.3; tanks and vessels**

Authority: IC 22-13-2-2; IC 22-13-2-13  
 Affected: IC 22-12; IC 22-13; IC 22-14; IC 22-15; IC 36-7

**Sec. 153.** Change the first sentence of Section 1622.4.3 Tanks and vessels to read as follows: This section applies to tanks and vessels storing liquids, gases, and granular solids that are within the scope of Section 101.2. (Fire Prevention and Building Safety Commission; 675 IAC 13-2.4-153)

**675 IAC 13-2.4-154 Section 1622.4.4; telecommunication towers**

Authority: IC 22-13-2-2; IC 22-13-2-13  
 Affected: IC 22-12; IC 22-13; IC 22-14; IC 22-15; IC 36-7

**Sec. 154.** Delete Section 1622.4.4 Telecommunication towers. (Fire Prevention and Building Safety Commission; 675 IAC 13-2.4-154)

**675 IAC 13-2.4-155 Section 1622.4.5; stacks and chimneys**

Authority: IC 22-13-2-2; IC 22-13-2-13  
 Affected: IC 22-12; IC 22-13; IC 22-14; IC 22-15; IC 36-7

## Proposed Rules

**Sec. 155.** Change the title of Section 1622.4.5 Stacks and chimneys to read as follows: **Stacks and chimneys within the scope of Section 101.2.** (*Fire Prevention and Building Safety Commission; 675 IAC 13-2.4-155*)

**675 IAC 13-2.4-156** Section 1622.4.6; amusement structures

Authority: IC 22-13-2-2; IC 22-13-2-13  
Affected: IC 22-12; IC 22-13; IC 22-14; IC 22-15; IC 36-7

**Sec. 156.** Change the title of Section 1622.4.6 Amusement structures to read as follows: **Amusement structures within the scope of Section 101.2.** (*Fire Prevention and Building Safety Commission; 675 IAC 13-2.4-156*)

**675 IAC 13-2.4-157** Section 1622.4.7; special hydraulic structures

Authority: IC 22-13-2-2; IC 22-13-2-13  
Affected: IC 22-12; IC 22-13; IC 22-14; IC 22-15; IC 36-7

**Sec. 157.** Change the title of Section 1622.4.7 Special hydraulic structures to read as follows: **Special hydraulic structures within the scope of Section 101.2.** (*Fire Prevention and Building Safety Commission; 675 IAC 13-2.4-157*)

**675 IAC 13-2.4-158** Section 1622.4.8; buried structures

Authority: IC 22-13-2-2; IC 22-13-2-13  
Affected: IC 22-12; IC 22-13; IC 22-14; IC 22-15; IC 36-7

**Sec. 158.** Change the title of Section 1622.4.8 Buried Structures to read as follows: **Buried structures within the scope of Section 101.2.** (*Fire Prevention and Building Safety Commission; 675 IAC 13-2.4-158*)

**675 IAC 13-2.4-159** Section 1622.4.9; inverted pendulum

Authority: IC 22-13-2-2; IC 22-13-2-13  
Affected: IC 22-12; IC 22-13; IC 22-14; IC 22-15; IC 36-7

**Sec. 159.** Change the title of Section 1622.4.9 Inverted pendulum to read as follows: **Inverted pendulums within the scope of Section 101.2.** (*Fire Prevention and Building Safety Commission; 675 IAC 13-2.4-159*)

**675 IAC 13-2.4-160** Section 1623; seismically isolated structures

Authority: IC 22-13-2-2; IC 22-13-2-13  
Affected: IC 22-12; IC 22-13; IC 22-14; IC 22-15; IC 36-7

**Sec. 160.** Change the title of Section 1623 Seismically isolated structures to read: **Seismically isolated structures within the scope of Section 101.2.** (*Fire Prevention and Building Safety Commission; 675 IAC 13-2.4-160*)

**675 IAC 13-2.4-161** Section 1623.5.1.8; inspection and replacement

Authority: IC 22-13-2-2; IC 22-13-2-13  
Affected: IC 22-12; IC 22-13; IC 22-14; IC 22-15; IC 36-7

**Sec. 161.** Delete section 1623.5.1.8 Inspection and replacement and substitute to read as follows: **Access for inspection and replacement of all components of the isolation system shall be provided.** (*Fire Prevention and Building Safety Commission; 675 IAC 13-2.4-161*)

**675 IAC 13-2.4-162** Section 1623.5.1.9; quality control

Authority: IC 22-13-2-2; IC 22-13-2-13  
Affected: IC 22-12; IC 22-13; IC 22-14; IC 22-15; IC 36-7

**Sec. 162.** Delete Section 1623.5.1.9 Quality control. (*Fire Prevention and Building Safety Commission; 675 IAC 13-2.4-162*)

**675 IAC 13-2.4-163** Section 1623.5.2.3; nonbuilding structures

Authority: IC 22-13-2-2; IC 22-13-2-13  
Affected: IC 22-12; IC 22-13; IC 22-14; IC 22-15; IC 36-7

**Sec. 163.** Change the title of Section 1623.5.2.3 Nonbuilding structures to read as follows: **Nonbuilding structures within the scope of Section 101.2.** (*Fire Prevention and Building Safety Commission; 675 IAC 13-2.4-163*)

**675 IAC 13-2.4-164** Section 1623.7; design and construction

Authority: IC 22-13-2-2; IC 22-13-2-13  
Affected: IC 22-12; IC 22-13; IC 22-14; IC 22-15; IC 36-7

**Sec. 164.** Delete Section 1623.7 Design and construction review and substitute the following: **See the General Administrative Rules (675 IAC 12-6).** (*Fire Prevention and Building Safety Commission; 675 IAC 13-2.4-164*)

**675 IAC 13-2.4-165** Chapter 17; structural test and special inspections

Authority: IC 22-13-2-2; IC 22-13-2-13  
Affected: IC 22-12; IC 22-13; IC 22-14; IC 22-15; IC 36-7

**Sec. 165.** Delete Chapter 17 Structural test and special inspections and substitute to read as follows: **See the General Administrative Rules (675 IAC 12-6-6(c)(10)(D) and Industrialized Building Systems (675 IAC 15).** (*Fire Prevention and Building Safety Commission; 675 IAC 13-2.4-165*)

**675 IAC 13-2.4-166** Section 1802.1; general

Authority: IC 22-13-2-2; IC 22-13-2-13  
Affected: IC 22-12; IC 22-13; IC 22-14; IC 22-15; IC 36-7

**Sec. 166.** Delete the last sentence of Section 1802.1 General. (*Fire Prevention and Building Safety Commission; 675 IAC 13-2.4-166*)

**675 IAC 13-2.4-167** Section 1802.6; reports

Authority: IC 22-13-2-2; IC 22-13-2-13  
Affected: IC 22-12; IC 22-13; IC 22-14; IC 22-15; IC 36-7

**Sec. 167.** Delete Section 1802.6 Reports and substitute as follows: **See the General Administrative Rules (675 IAC 12-**



**6) and the rules for Industrialized Building Systems (675 IAC 15).** (*Fire Prevention and Building Safety Commission; 675 IAC 13-2.4-167*)

**675 IAC 13-2.4-168 Section 1803.3; site grading**

Authority: IC 22-13-2-2; IC 22-13-2-13  
Affected: IC 22-12; IC 22-13; IC 22-14; IC 22-15; IC 36-7

**Sec. 168. Delete the Exception to Section 1803.3 Site grading.** (*Fire Prevention and Building Safety Commission; 675 IAC 13-2.4-168*)

**675 IAC 13-2.4-169 Section 1803.4; compacted fill material**

Authority: IC 22-13-2-2; IC 22-13-2-13  
Affected: IC 22-12; IC 22-13; IC 22-14; IC 22-15; IC 36-7

**Sec. 169. Delete in Section 1803.4 Compacted fill material the last sentence of the Exception.** (*Fire Prevention and Building Safety Commission; 675 IAC 13-2.4-169*)

**675 IAC 13-2.4-170 Section 1805.3.3; pools**

Authority: IC 22-13-2-2; IC 22-13-2-13  
Affected: IC 22-12; IC 22-13; IC 22-14; IC 22-15; IC 36-7

**Sec. 170. Delete in Section 1805.3.3 Pools the words “this code” and substitute the words “the Indiana Swimming Pool Code (675 IAC 20)”.** (*Fire Prevention and Building Safety Commission; 675 IAC 13-2.4-170*)

**675 IAC 13-2.4-171 Section 1805.4.2.6; forming of concrete**

Authority: IC 22-13-2-2; IC 22-13-2-13  
Affected: IC 22-12; IC 22-13; IC 22-14; IC 22-15; IC 36-7

**Sec. 171. Delete in Section 1805.4.2.6 Forming of concrete the words “building official” and substitute the words “registered design professional”.** (*Fire Prevention and Building Safety Commission; 675 IAC 13-2.4-171*)

**675 IAC 13-2.4-172 Table 1805.5(1); plain masonry and plain concrete foundation walls**

Authority: IC 22-13-2-2; IC 22-13-2-13  
Affected: IC 22-12; IC 22-13; IC 22-14; IC 22-15; IC 36-7

**Sec. 172. Change TABLE 1805.5(1) PLAIN MASONRY AND PLAIN CONCRETE FOUNDATION WALLS as follows: Under Plain Masonry, for a wall height of 8 feet, unbalanced backfill height of 8 feet, and soil lateral load of 30 psf, change “10 (solid<sup>b</sup>)” to “10 (solid)”.** (*Fire Prevention and Building Safety Commission; 675 IAC 13-2.4-172*)

**675 IAC 13-2.4-173 Section 1807.2.8.3; load test**

Authority: IC 22-13-2-2; IC 22-13-2-13  
Affected: IC 22-12; IC 22-13; IC 22-14; IC 22-15; IC 36-7

**Sec. 173. Delete in Section 1807.2.8.3 Load tests the words “building official” and substitute the words “registered design professional”.** (*Fire Prevention and Building Safety Commission; 675 IAC 13-2.4-173*)

**675 IAC 13-2.4-174 Section 1807.2.21; pier or pile location plan**

Authority: IC 22-13-2-2; IC 22-13-2-13  
Affected: IC 22-12; IC 22-13; IC 22-14; IC 22-15; IC 36-7

**Sec. 174. Delete Section 1807.2.21 Pier or pile location plan and substitute as follows: See the General Administrative Rules (675 IAC 12-6) and the rules for Industrialized Building Systems (675 IAC 15).** (*Fire Prevention and Building Safety Commission; 675 IAC 13-2.4-174*)

**675 IAC 13-2.4-175 Section 1807.2.22; special inspections**

Authority: IC 22-13-2-2; IC 22-13-2-13  
Affected: IC 22-12; IC 22-13; IC 22-14; IC 22-15; IC 36-7

**Sec. 175. Delete Section 1807.2.22 Special inspections and substitute: See the General Administrative Rules (675 IAC 12-6-6(c)(10)(D)) and the rules for Industrialized Building Systems (675 IAC 15).** (*Fire Prevention and Building Safety Commission; 675 IAC 13-2.4-175*)

**675 IAC 13-2.4-176 Section 1807.2.23.1; seismic design Category C**

Authority: IC 22-13-2-2; IC 22-13-2-13  
Affected: IC 22-12; IC 22-13; IC 22-14; IC 22-15; IC 36-7

**Sec. 176. Change Section 1807.2.23.1 Seismic design Category C to read as follows: Where a structure is assigned to Seismic Design Category C in accordance with Section 1616, the following shall apply. Individual pile caps, piers or piles shall be interconnected by ties. Ties shall be capable of carrying, in tension and compression, a force equal to the product of the larger pile cap or column load times the seismic coefficient  $S_{DS}$  divided by 10 unless it can be demonstrated that equivalent restraint is provided by reinforced concrete beams within slabs-on-grade or reinforced concrete slabs-on-grade or confinement by competent rock, hard cohesive soils, or very dense granular soils.**

**Exception 1: Piers supporting foundation walls, isolated interior posts detailed so the pier is not subject to lateral, lightly loaded exterior decks and patios, of Group R, Division 3 and Group U, Division 1 occupancies not exceeding two stories of light-frame construction, are not subject to interconnection if it can be shown the soils are of adequate stiffness, subject to the approval of the building official.**

**Exception 2: Other methods may be used where it can be demonstrated by a registered design professional that equivalent restraint can be provided when approved by the building official.**

(*Fire Prevention and Building Safety Commission; 675 IAC 13-2.4-176*)

**675 IAC 13-2.4-177 Section 1809.3.2; dimensions**

Authority: IC 22-13-2-2; IC 22-13-2-13  
Affected: IC 22-12; IC 22-13; IC 22-14; IC 22-15; IC 36-7

## Proposed Rules

**Sec. 177. Change the Exception to Section 1809.3.2 Dimensions to read as follows: The length of the pile is permitted to exceed 30 times the diameter when approved by the building official.** (*Fire Prevention and Building Safety Commission; 675 IAC 13-2.4-177*)

**675 IAC 13-2.4-178 Section 1809.4.2; dimensions**

Authority: IC 22-13-2-2; IC 22-13-2-13

Affected: IC 22-12; IC 22-13; IC 22-14; IC 22-15; IC 36-7

**Sec. 178. Change the Exception to Section 1809.4.2 Dimensions to read as follows: The length of the pile is permitted to exceed 30 times the diameter when documented by the registered design professional and approved by the building official.** (*Fire Prevention and Building Safety Commission; 675 IAC 13-2.4-178*)

**675 IAC 13-2.4-179 Section 1811.4; reinforcement**

Authority: IC 22-13-2-2; IC 22-13-2-13

Affected: IC 22-12; IC 22-13; IC 22-14; IC 22-15; IC 36-7

**Sec. 179. Change at the end of the Exception to Section 1811.4 Reinforcement the words “building official” to the words “registered design professional”.** (*Fire Prevention and Building Safety Commission; 675 IAC 13-2.4-179*)

**675 IAC 13-2.4-180 Section 1901.4; construction documents**

Authority: IC 22-13-2-2; IC 22-13-2-13

Affected: IC 22-12; IC 22-13; IC 22-14; IC 22-15; IC 36-7

**Sec. 180. Delete Section 1901.4 Construction documents and substitute as follows: See the General Administrative Rules (675 IAC 12-6) and the rules for Industrialized Building Systems (675 IAC 15).** (*Fire Prevention and Building Safety Commission; 675 IAC 13-2.4-180*)

**675 IAC 13-2.4-181 Section 1903.6; admixtures**

Authority: IC 22-13-2-2; IC 22-13-2-13

Affected: IC 22-12; IC 22-13; IC 22-14; IC 22-15; IC 36-7

**Sec. 181. Change in Section 1903.6 Admixtures the word “approval” to the word “acceptance”.** (*Fire Prevention and Building Safety Commission; 675 IAC 13-2.4-181*)

**675 IAC 13-2.4-182 Section 1905.6.1; tests**

Authority: IC 22-13-2-2; IC 22-13-2-13

Affected: IC 22-12; IC 22-13; IC 22-14; IC 22-15; IC 36-7

**Sec. 182. Change the title and text of Section 1905.6.1 to read as follows: 1905.6.1 Tests. Concrete shall be tested in accordance with the requirements in Section 1905.6.2 through 1905.6.5.** (*Fire Prevention and Building Safety Commission; 675 IAC 13-2.4-182*)

**675 IAC 13-2.4-183 Section 1905.6.4.1; when required**

Authority: IC 22-13-2-2; IC 22-13-2-13

Affected: IC 22-12; IC 22-13; IC 22-14; IC 22-15; IC 36-7

**Sec. 183. Change Section 1905.6.4.1 When required to read as follows: The building official may require that the results of strength tests of cylinders cured under field conditions be provided.** (*Fire Prevention and Building Safety Commission; 675 IAC 13-2.4-183*)

**675 IAC 13-2.4-184 Section 1905.7; preparation of equipment and place of deposit**

Authority: IC 22-13-2-2; IC 22-13-2-13

Affected: IC 22-12; IC 22-13; IC 22-14; IC 22-15; IC 36-7

**Sec. 184. Change in item 6 of Section 1905.7 Preparation of equipment and place of deposit the word “permitted” to “approved”.** (*Fire Prevention and Building Safety Commission; 675 IAC 13-2.4-184*)

**675 IAC 13-2.4-185 Section 1905.6.5.5; strength evaluation**

Authority: IC 22-13-2-2; IC 22-13-2-13

Affected: IC 22-12; IC 22-13; IC 22-14; IC 22-15; IC 36-7

**Sec. 185. Change Section 1905.6.5.5 Strength evaluation to read as follows: If the criteria of Section 1905.6.5.4 are not met and if the structural adequacy remains in doubt, the building official is permitted to order a strength evaluation in accordance with Chapter 20, for the questionable portion of the structure.** (*Fire Prevention and Building Safety Commission; 675 IAC 13-2.4-185*)

**675 IAC 13-2.4-186 Section 1905.10.4; retempering**

Authority: IC 22-13-2-2; IC 22-13-2-13

Affected: IC 22-12; IC 22-13; IC 22-14; IC 22-15; IC 36-7

**Sec. 186. Change in Section 1905.10.4 Retempering the word “approved” to the word “authorized”.** (*Fire Prevention and Building Safety Commission; 675 IAC 13-2.4-186*)

**675 IAC 13-2.4-187 Section 1906.3; conduits and pipes embedded in concrete**

Authority: IC 22-13-2-2; IC 22-13-2-13

Affected: IC 22-12; IC 22-13; IC 22-14; IC 22-15; IC 36-7

**Sec. 187. Change in Section 1906.3 Conduits and pipes embedded in concrete the words “with approval of” to the words “when authorized by”.** (*Fire Prevention and Building Safety Commission; 675 IAC 13-2.4-187*)

**675 IAC 13-2.4-188 Section 1907.5.1; support**

Authority: IC 22-13-2-2; IC 22-13-2-13

Affected: IC 22-12; IC 22-13; IC 22-14; IC 22-15; IC 36-7

**Sec. 188. Change in Section 1907.5.1 Support the words “where approved” to the words “when authorized”.** (*Fire Prevention and Building Safety Commission; 675 IAC 13-2.4-188*)

**675 IAC 13-2.4-189 Section 1910.4.4.1; walls**

Authority: IC 22-13-2-2; IC 22-13-2-13

Affected: IC 22-12; IC 22-13; IC 22-14; IC 22-15; IC 36-7

**Sec. 189. Delete in Section 1910.4.4.1 Walls the Exception and substitute as follows: See Section 101.2.** (*Fire Prevention and Building Safety Commission; 675 IAC 13-2.4-189*)

**675 IAC 13-2.4-190 Section 1910.4.4.2; footings**

Authority: IC 22-13-2-2; IC 22-13-2-13  
Affected: IC 22-12; IC 22-13; IC 22-14; IC 22-15; IC 36-7

**Sec. 190. Change Section 1910.4.4.2 Footings as follows:**  
**(1) Delete the Exception at the end of the first paragraph and substitute to read as follows: See Section 101.2.**

**(2) Delete Exception 1 of the second paragraph and substitute to read as follows: See Section 101.2.**

(*Fire Prevention and Building Safety Commission; 675 IAC 13-2.4-190*)

**675 IAC 13-2.4-191 Section 1912.5; increase for special inspections**

Authority: IC 22-13-2-2; IC 22-13-2-13  
Affected: IC 22-12; IC 22-13; IC 22-14; IC 22-15; IC 36-7

**Sec. 191. Delete Section 1912.5 Increase for special inspections.** (*Fire Prevention and Building Safety Commission; 675 IAC 13-2.4-191*)

**675 IAC 13-2.4-192 Section 1913.8.3; construction documents**

Authority: IC 22-13-2-2; IC 22-13-2-13  
Affected: IC 22-12; IC 22-13; IC 22-14; IC 22-15; IC 36-7

**Sec. 192. Delete Section 1913.8.3 Construction documents and substitute as follows: See the General Administrative Rules (675 IAC 12-6) and the rules for Industrialized Building Systems (675 IAC 15).** (*Fire Prevention and Building Safety Commission; 675 IAC 13-2.4-192*)

**675 IAC 13-2.4-193 Section 1914.5; preconstruction tests**

Authority: IC 22-13-2-2; IC 22-13-2-13  
Affected: IC 22-12; IC 22-13; IC 22-14; IC 22-15; IC 36-7

**Sec. 193. Delete at the beginning of Section 1914.5 Preconstruction tests the words “When required by the building official” and substitute the words “When required by local ordinance”.** (*Fire Prevention and Building Safety Commission; 675 IAC 13-2.4-193*)

**675 IAC 13-2.4-194 Section 1914.7; joints**

Authority: IC 22-13-2-2; IC 22-13-2-13  
Affected: IC 22-12; IC 22-13; IC 22-14; IC 22-15; IC 36-7

**Sec. 194. Delete in Section 1914.7 Joints the word “approved”.** (*Fire Prevention and Building Safety Commission; 675 IAC 13-2.4-194*)

**675 IAC 13-2.4-195 Section 1916.6; approvals**

Authority: IC 22-13-2-2; IC 22-13-2-13  
Affected: IC 22-12; IC 22-13; IC 22-14; IC 22-15; IC 36-7

**Sec. 195. Change the last sentence of Section 1916.6 Approvals to read as follows: Shop-fabricated concrete-filled pipe columns shall be approved by the building official.** (*Fire Prevention and Building Safety Commission; 675 IAC 13-2.4-195*)

**675 IAC 13-2.4-196 Section 2101.3; construction documents**

Authority: IC 22-13-2-2; IC 22-13-2-13  
Affected: IC 22-12; IC 22-13; IC 22-14; IC 22-15; IC 36-7

**Sec. 196. Delete Sections 2101.3 Construction documents and 2101.3.1 Fireplace drawings and substitute to read as follows: See the General Administrative Rules (675 IAC 12-6) and the rules for Industrialized Building Systems (675 IAC 15).** (*Fire Prevention and Building Safety Commission; 675 IAC 13-2.4-196*)

**675 IAC 13-2.4-197 Section 2102; definitions**

Authority: IC 22-13-2-2; IC 22-13-2-13  
Affected: IC 22-12; IC 22-13; IC 22-14; IC 22-15; IC 36-7

**Sec. 197. Change in Section 2102 Definitions and notations in the definition of MASONRY the word “accepted” to “approved”.** (*Fire Prevention and Building Safety Commission; 675 IAC 13-2.4-197*)

**675 IAC 13-2.4-198 Section 2104.1.2.3; solid units**

Authority: IC 22-13-2-2; IC 22-13-2-13  
Affected: IC 22-12; IC 22-13; IC 22-14; IC 22-15; IC 36-7

**Sec. 198. Change the first sentence of Section 2104.1.2.3 solid units to read as follows: Unless otherwise approved, solid units shall be placed in fully mortared bed and head joints.** (*Fire Prevention and Building Safety Commission; 675 IAC 13-2.4-198*)

**675 IAC 13-2.4-199 Section 2105.1; general**

Authority: IC 22-13-2-2; IC 22-13-2-13  
Affected: IC 22-12; IC 22-13; IC 22-14; IC 22-15; IC 36-7

**Sec. 199. Delete Section 2105.1 General.** (*Fire Prevention and Building Safety Commission; 675 IAC 13-2.4-199*)

**675 IAC 13-2.4-200 Section 2105.4; mortar testing**

Authority: IC 22-13-2-2; IC 22-13-2-13  
Affected: IC 22-12; IC 22-13; IC 22-14; IC 22-15; IC 36-7

**Sec. 200. Change Section 2105.4 Mortar testing to read as follows: When required by local ordinance, mortar shall be tested in accordance with the property specifications of ASTM C-270 or evaluated in accordance with ASTM C-780.** (*Fire Prevention and Building Safety Commission; 675 IAC 13-2.4-200*)

**675 IAC 13-2.4-201 Section 2107.2.1; ACI 530/ASCE 5/Tms 402 Chapter 2**

Authority: IC 22-13-2-2; IC 22-13-2-13  
Affected: IC 22-12; IC 22-13; IC 22-14; IC 22-15; IC 36-7

## Proposed Rules

**Sec. 201. Delete Section 2107.2.1 ACI 530/ASCE 5/TMS 402 Chapter 2.** (*Fire Prevention and Building Safety Commission; 675 IAC 13-2.4-201*)

**675 IAC 13-2.4-202 Section 2108.2; quality assurance provisions**

Authority: IC 22-13-2-2; IC 22-13-2-13

Affected: IC 22-12; IC 22-13; IC 22-14; IC 22-15; IC 36-7

**Sec. 202. Delete Section 2108.2 Quality assurance provisions.** (*Fire Prevention and Building Safety Commission; 675 IAC 13-2.4-202*)

**675 IAC 13-2.4-203 Section 2208.1; welding**

Authority: IC 22-13-2-2; IC 22-13-2-13

Affected: IC 22-12; IC 22-13; IC 22-14; IC 22-15; IC 36-7

**Sec. 203. Delete the last sentence of Section 2208.1 Welding.** (*Fire Prevention and Building Safety Commission; 675 IAC 13-2.4-203*)

**675 IAC 13-2.4-204 Section 2209; general**

Authority: IC 22-13-2-2; IC 22-13-2-13

Affected: IC 22-12; IC 22-13; IC 22-14; IC 22-15; IC 36-7

**Sec. 204. Delete the last sentence of Section 2209.1 General.** (*Fire Prevention and Building Safety Commission; 675 IAC 13-2.4-204*)

**675 IAC 13-2.4-205 Section 2210; steel storage racks**

Authority: IC 22-13-2-2; IC 22-13-2-13

Affected: IC 22-12; IC 22-13; IC 22-14; IC 22-15; IC 36-7

**Sec. 205. Delete Section 2210 Steel storage racks and substitute as follows: Where steel storage racks are part of the structural system of a Class 1 structure the storage racks shall comply with this code.** (*Fire Prevention and Building Safety Commission; 675 IAC 13-2.4-205*)

**675 IAC 13-2.4-206 Section 2303.1.1; lumber**

Authority: IC 22-13-2-2; IC 22-13-2-13

Affected: IC 22-12; IC 22-13; IC 22-14; IC 22-15; IC 36-7

**Sec. 206. Delete in the first sentence of Section 2303.1.1 Lumber the words "by an accreditation body that complies with DOC PS20 or equivalent".** (*Fire Prevention and Building Safety Commission; 675 IAC 13-2.4-206*)

**675 IAC 13-2.4-207 Section 2303.1.8.1; identification**

Authority: IC 22-13-2-2; IC 22-13-2-13

Affected: IC 22-12; IC 22-13; IC 22-14; IC 22-15; IC 36-7

**Sec. 207. Change Section 2303.1.8.1 Identification to read as follows: Wood required by Section 2304.11 to be preservative-treated shall bear the quality mark of an inspection agency that maintains continuing supervision, testing and inspection over the quality of the preservative-treated wood and shall be approved by the building official. The quality mark shall be on a stamp or label affixed to the**

**preservative-treated wood. The quality mark shall include the following:**

1. Identification of treating manufacturer.
2. Type of preservative used.
3. Minimum preservative retention (pef).
4. End use for which the product is treated.
5. AWWPA standard to which the product was treated.
6. Identity of the accredited inspection agency.

(*Fire Prevention and Building Safety Commission; 675 IAC 13-2.4-207*)

**675 IAC 13-2.4-208 Section 2303.2.1; labeling**

Authority: IC 22-13-2-2; IC 22-13-2-13

Affected: IC 22-12; IC 22-13; IC 22-14; IC 22-15; IC 36-7

**Sec. 208. Change Section 2303.2.1 Labeling to read as follows: Fire-retardant-treated lumber and wood structural panels shall bear the identification mark of an approved agency. Such identification marks shall indicate conformance with appropriate standards in accordance with Sections 2303.2.2 through 2303.2.5.** (*Fire Prevention and Building Safety Commission; 675 IAC 13-2.4-208*)

**675 IAC 13-2.4-209 Section 2303.4; trusses**

Authority: IC 22-13-2-2; IC 22-13-2-13

Affected: IC 22-12; IC 22-13; IC 22-14; IC 22-15; IC 36-7

**Sec. 209. Delete Section 2303.4 Trusses and substitute to read as follows: Metal plate connected wood trusses shall be manufactured as required by TPI 1.** (*Fire Prevention and Building Safety Commission; 675 IAC 13-2.4-209*)

**675 IAC 13-2.4-210 Section 2303.4.1; truss design drawings**

Authority: IC 22-13-2-2; IC 22-13-2-13

Affected: IC 22-12; IC 22-13; IC 22-14; IC 22-15; IC 36-7

**Sec. 210. Delete 2303.4.1 Truss design drawings and substitute as follows: See the General Administrative Rules (675 IAC 12-6) and Industrialized Building Systems (675 IAC 15).** (*Fire Prevention and Building Safety Commission; 675 IAC 13-2.4-210*)

**675 IAC 13-2.4-211 Section 2303.5; test standard for joist hangers and connectors**

Authority: IC 22-13-2-2; IC 22-13-2-13

Affected: IC 22-12; IC 22-13; IC 22-14; IC 22-15; IC 36-7

**Sec. 211. Delete Section 2303.5 Test standard for joist hangers and connectors and substitute as follows: Joist hangers and connectors shall be approved.** (*Fire Prevention and Building Safety Commission; 675 IAC 13-2.4-211*)

**675 IAC 13-2.4-212 Section 2304.9.3; joist hangers and framing anchors**

Authority: IC 22-13-2-2; IC 22-13-2-13

Affected: IC 22-12; IC 22-13; IC 22-14; IC 22-15; IC 36-7

**Sec. 212. Delete the last sentence of Section 2304.9.3 Joist**

**hangers and framing anchors.** (*Fire Prevention and Building Safety Commission; 675 IAC 13-2.4-212*)

**675 IAC 13-2.4-213 Section 2304.11.2; wood used above ground**

Authority: IC 22-13-2-2; IC 22-13-2-13  
Affected: IC 22-12; IC 22-13; IC 22-14; IC 22-15; IC 36-7

**Sec. 213. Change the last line of Section 2304.11.2 Wood used above ground to read as follows: Standards for above ground use as referenced in Chapter 35.** (*Fire Prevention and Building Safety Commission; 675 IAC 13-2.4-213*)

**675 IAC 13-2.4-214 Section 2304.11.5; supporting member for permanent appurtenances**

Authority: IC 22-13-2-2; IC 22-13-2-13  
Affected: IC 22-12; IC 22-13; IC 22-14; IC 22-15; IC 36-7

**Sec. 214. Delete the Exception to Section 2304.11.5 Supporting member for permanent appurtenances.** (*Fire Prevention and Building Safety Commission; 675 IAC 13-2.4-214*)

**675 IAC 13-2.4-215 Section 2308.1; general**

Authority: IC 22-13-2-2; IC 22-13-2-13  
Affected: IC 22-12; IC 22-13; IC 22-14; IC 22-15; IC 36-7

**Sec. 215. Change the second sentence of Section 2308.1 General to read as follows: Other methods are permitted to be used where the design has been approved and the design shows compliance with other provisions of this code.** (*Fire Prevention and Building Safety Commission; 675 IAC 13-2.4-215*)

**675 IAC 13-2.4-216 Sections 2308.11.1 and 2308.12.1; numbers of stories**

Authority: IC 22-13-2-2; IC 22-13-2-13  
Affected: IC 22-12; IC 22-13; IC 22-14; IC 22-15; IC 36-7

**Sec. 216. Delete the Exception to Sections 2308.11.1 and 2308.12.1 Number of stories and substitute: See Section 101.2.** (*Fire Prevention and Building Safety Commission; 675 IAC 13-2.4-216*)

**675 IAC 13-2.4-217 Section 2403.1; safety glazing**

Authority: IC 22-13-2-2; IC 22-13-2-13  
Affected: IC 22-12; IC 22-13; IC 22-14; IC 22-15; IC 36-7

**Sec. 217. Change the first paragraph of Section 2403.1 to read as follows: Each pane shall bear the manufacturer's label designating the type and thickness of the glass or glazing material. The identification shall not be omitted unless approved and an affidavit is furnished by the glazing contractor certifying that each light is glazed in accordance with the provisions of this chapter. Safety glazing shall be identified in accordance with Section 2406.1.1.** (*Fire Prevention and Building Safety Commission; 675 IAC 13-2.4-217*)

**675 IAC 13-2.4-218 Section 2603.4.1.9; garage doors**

Authority: IC 22-13-2-2; IC 22-13-2-13  
Affected: IC 22-12; IC 22-13; IC 22-14; IC 22-15; IC 36-7

**Sec. 218. Delete the Exception to Section 2603.4.1.9 Garage doors, and substitute as follows: See Section 101.2.** (*Fire Prevention and Building Safety Commission; 675 IAC 13-2.4-218*)

**675 IAC 13-2.4-219 Section 2606.3; identification**

Authority: IC 22-13-2-2; IC 22-13-2-13  
Affected: IC 22-12; IC 22-13; IC 22-14; IC 22-15; IC 36-7

**Sec. 219. Change in Section 2606.3 Identification, the words "satisfactory to" to the words "approved by".** (*Fire Prevention and Building Safety Commission; 675 IAC 13-2.4-219*)

**675 IAC 13-2.4-220 Section 2606.5; structural requirements**

Authority: IC 22-13-2-2; IC 22-13-2-13  
Affected: IC 22-12; IC 22-13; IC 22-14; IC 22-15; IC 36-7

**Sec. 220. Delete Section 2606.5 Structural requirements, and substitute to read as follows: Light-transmitting plastic materials in their assembly shall be of adequate strength and durability to withstand the loads indicated in Chapter 16 and shall be approved by the building official.** (*Fire Prevention and Building and Safety Commission; 675 IAC 13-2.4-220*)

**675 IAC 13-2.4-221 Chapter 27; electrical**

Authority: IC 22-13-2-2; IC 22-13-2-13  
Affected: IC 22-12; IC 22-13; IC 22-14; IC 22-15; IC 36-7

**Sec. 221. Delete Chapter 27 Electrical, and substitute to read as follows: See the Indiana Electrical Code (675 IAC 17).** (*Fire Prevention and Building Safety Commission; 675 IAC 13-2.4-221*)

**675 IAC 13-2.4-222 Chapter 28; mechanical systems**

Authority: IC 22-13-2-2; IC 22-13-2-13  
Affected: IC 22-12; IC 22-13; IC 22-14; IC 22-15; IC 36-7

**Sec. 222. Delete Chapter 28 Mechanical systems, and substitute to read as follows: See the Indiana Mechanical Code (675 IAC 18) and the Indiana Fuel Gas Code (675 IAC 25).** (*Fire Prevention and Building Safety Commission; 675 IAC 13-2.4-222*)

**675 IAC 13-2.4-223 Chapter 29; plumbing systems**

Authority: IC 22-13-2-2; IC 22-13-2-13  
Affected: IC 22-12; IC 22-13; IC 22-14; IC 22-15; IC 36-7

**Sec. 223. Delete the text of Chapter 29 and substitute as follows:**

**SECTION 2901. PLUMBING CODE**

**Plumbing systems shall comply with the plumbing code. (675 IAC 16).**

**SECTION 2902. Minimum number of fixtures. Plumbing fixtures shall be provided for the type of occupancy and in**

## Proposed Rules

the minimum number shown in TABLE No. 29. Types of occupancies not shown in TABLE No. 29 shall be considered as the most similar listed occupancy.

The number of occupants of a building, for the purposes of Chapter 29, shall be one of the following:

1. The actual or anticipated number of occupants; or
2. The square feet of usable (net) floor space divided by the occupant load factor found in Table 10-A.

**SECTION 2903.** Where plumbing fixtures are required separate facilities shall be provided for each sex.

**EXCEPTIONS:**

1. Separate facilities shall not be required in residential occupancies.
2. Separate employee facilities shall not be required in occupancies in which fifteen (15) or less people are employed.
3. Separate facilities shall not be required in structures or tenant space with a total occupant load, including both employees and customers, of fifteen (15) or less in which food or beverage is served for consumption within the structure or tenant space.

**SECTION 2904.** Number of occupants of each sex: The required water closets, lavatories, and showers or bathtubs shall be distributed equally, except where specified in TABLE No. 29, between the sexes based on the percentage load of each sex anticipated in the occupant load. The occupant load shall be composed of fifty percent (50%) of each sex unless statistical data indicates a different distribution of the sexes.

**SECTION 2905.** Location of employee toilet facilities in occupancies other than use Group A or M occupancies: Access to toilet facilities in occupancies other than use Group A or M occupancies shall be from within the employee's regular working area. The required toilet facilities shall not exceed a distance of five hundred (500) feet (one hundred fifty-two (152) meters). Employee facilities shall be either separate facilities or public facilities.

**EXCEPTION:** Facilities that are required for employees in storage structures or kiosks, and which are located in adjacent structures under the same ownership, lease, or control, shall be a maximum travel distance of five hundred (500) feet (one hundred fifty-two (152) meters) from the employees' regular working area.

1. Location of employee toilet facilities in buildings of use Groups A and M occupancies: Employees shall be provided with toilet facilities in buildings and tenant spaces utilized as restaurants, nightclubs, places of public assembly, and retail sales occupancies. The employee facilities shall be either separate facilities or public facilities.

**EXCEPTION:** Employee toilet facilities shall not be

required in tenant spaces of nine hundred (900) square feet (eighty-four (84) meters squared) or less where the travel distance from the main entrance of the tenant space to a central toilet area does not exceed five hundred (500) feet (one hundred fifty-two (152) meters) and such central toilet facilities are located not more than one (1) story above or below the tenant space.

**SECTION 2906.** Public facilities: The public shall be provided with toilet facilities in structures and tenant spaces utilized as restaurants, nightclubs, places of assembly, and retail sales occupancies. Public toilet facilities shall be located not more than one (1) story above or below the space required to be provided with public toilet facilities and the path of travel to such facilities shall not exceed a distance of five hundred (500) feet (one hundred fifty-two (152) meters). In covered mall buildings, required facilities shall be based on total square footage, and facilities shall be installed in each individual store or in a central toilet area located in accordance with this section. The maximum travel distance to the central toilet facilities in covered mall buildings shall be measured from the main entrance of any store or tenant space.

**EXCEPTION:** Public facilities are not required in structures or tenant spaces with an occupant load of less than one hundred fifty (150) and which do not serve food or beverages to be consumed within the structure or tenant space.

**SECTION 2907.** Access for cleaning: Plumbing fixtures shall be installed so as to afford access for cleaning both the fixture and area around the fixture. Unless conditions such as freezing or structural impairment restricts, all pipes from fixtures shall be routed to the nearest wall.

**SECTION 2908.** Convenience and function: Fixtures shall be set level and in alignment with reference to adjacent walls.

1. Water closets, lavatories and bidets: A water closet, lavatory, or bidet shall not be set closer than fifteen (15) inches (three hundred eighty-two (382) millimeters) from its center to any side wall, partition, vanity, or other obstruction, nor closer than thirty (30) inches (four hundred fifty-seven (457) millimeters) clearance in front of the water closet or bidet to any wall, fixture, or door. Water closet compartments shall not be less than thirty (30) inches (seven hundred sixty-two (762) millimeters) wide and sixty (60) inches (one thousand five hundred twenty-four (1,524) millimeters) deep. There shall be at least eighteen (18) inches (four hundred fifty-seven (457) millimeters) clearance in front of a lavatory to any wall, fixture or door. See Figure 29.

2. Urinals: A urinal shall not be set closer than fifteen (15) inches (three hundred eighty-one (381) millimeters) from the center of the urinal to any side wall, partition, vanity or other obstruction, nor closer than thirty (30) inches

## Proposed Rules

(seven hundred sixty-two (762) millimeters) center-to-center between urinals.

**SECTION 2909. Drinking Fountains.** Where required by TABLE No. 29, drinking fountains shall be installed.

**EXCEPTIONS:**

1. Where water is served in restaurants or where bottled water coolers are provided in other occupancies, drinking fountains shall not be required.
2. Drinking fountains shall not be installed in public rest rooms or nonprivate bathrooms.

**SECTION 2910. Substitution of urinals for water closets.** In each bathroom or toilet room, urinals shall not be substituted for more than fifty percent (50%) of the required water closets.

**SECTION 2911. Access:** Where access by persons with a disability is required by Chapter 11, accessible toilet and other facilities shall be provided as specified in that chapter.

**SECTION 2912. Unisex bathing and toilet rooms.**

**2912.1 General.** Unisex bathing and toilet rooms shall comply with this section and Chapter 11.

In Groups A and M Occupancies, an accessible unisex toilet room shall be provided where an aggregate of six (6) or more male and female water closets are required. In buildings of mixed occupancy, only those water closets required for the Group A or M Occupancy shall be used to determine the unisex toilet room requirement.

**2912.2 Location.** Unisex toilet and bathing rooms shall be located on an accessible route. Unisex toilet rooms shall be

located not more than one (1) story above or below separate-sex toilet facilities. The accessible route from any separate-sex toilet room to a unisex toilet room shall not exceed five hundred (500) feet (one hundred fifty-two thousand four hundred (152,400) millimeters).

Additionally, in passenger transportation facilities and airports, the accessible route from separate-sex toilet facilities to a unisex toilet room shall not pass through security checkpoints.

**2912.3 Clear floor space.** Where doors swing into a unisex toilet or bathing room, a clear floor space not less than thirty (30) inches by forty-eight (48) inches (seven hundred sixty-two (762) millimeters) by one thousand two hundred nineteen (1,219) millimeters shall be provided within the room, beyond the area of the door swing.

**2912.4 Required fixtures.**

**2912.4.1 Unisex toilet rooms.** Unisex toilet rooms shall include only one (1) water closet and only one (1) lavatory. Where a bathing facility is provided within a unisex toilet room, only one (1) shower shall be provided.

**EXCEPTION:** A separate-sex toilet room containing not more than two (2) water closets without urinals, or containing only one (1) water closet and one (1) urinal, may be considered a unisex toilet room.

**2912.4.2 Unisex bathing rooms.** Unisex bathing rooms shall include one (1) shower fixture. Unisex bathing rooms shall also include one (1) water closet and one (1) lavatory. Where storage facilities are provided for separate-sex bathing facilities, accessible storage facilities shall be provided for unisex bathing rooms.

**TABLE NO. 29  
MINIMUM NUMBER OF PLUMBING FACILITIES  
Fixtures**

Number of fixtures per number of occupants

Building Occupancy	Water Closets		Lavatories	Bathtubs/ showers	Drinking Fountains	Service Sink	
	Males	Females					
A	Theaters	1 per 125	1 per 65	1 per 200	--	1 per 1,000	1
	Night Clubs	1 per 40	1 per 40	1 per 75	--	1 per 500	1
	Restaurants	1 per 75	1 per 75	1 per 200	--	1 per 500	1
	Halls, museums, etc.	1 per 125	1 per 65	1 per 200	--	1 per 1,000	1
	Coliseums, arenas	1 per 75	1 per 40	1 per 150	--	1 per 1,000	1
	Churches(b)	1 per 150	1 per 75	1 per 200	--	1 per 1,000	1
	Stadiums, pools, etc.	1 per 100	1 per 50	1 per 150	--	1 per 1,000	1
B	Business	1 per 25		1 per 40	--	1 per 100	1
M	Retail Sales	1 per 500		1 per 750	--	1 per 1,000	1

## Proposed Rules

<b>F</b>	<b>Factory and industrial</b>	<b>1 per 100</b>	<b>1 per 100</b>	<b>emergency showers and eyewash</b>	<b>1 per 400</b>	<b>1</b>
<b>S</b>	<b>Storage</b>	<b>1 per 100</b>	<b>1 per 100</b>	<b>emergency showers and eyewash</b>	<b>1 per 1,000</b>	<b>1</b>
<b>E</b>	<b>Educational</b>	<b>1 per 50</b>	<b>1 per 50</b>	<b>--</b>	<b>1 per 100</b>	<b>1</b>
<b>H</b>	<b>Hazardous</b>	<b>1 per 100</b>	<b>1 per 100</b>	<b>emergency showers and eyewash</b>	<b>1 per 1,000</b>	<b>1</b>
<b>I</b>	<b>Hospitals(c)</b>	<b>1 per room (f)</b>	<b>1 per room (f)</b>	<b>1 per 15</b>	<b>1 per 100</b>	<b>1 per floor</b>
	<b>I-1 Nurseries, day care centers, sanitariums, and nursing homes with nonambulatory patients (c)</b>	<b>1 per 15</b>	<b>1 per 15</b>	<b>1 per 15 (g)</b>	<b>1 per 100</b>	<b>1</b>
	<b>I-2 Nursing homes for ambulatory patients (c)</b>	<b>1 per room (f)</b>	<b>1 per room (f)</b>	<b>1 per 15</b>	<b>1 per 100</b>	<b>1 per floor</b>
	<b>I-3 Mental hospitals, mental sanitariums, etc.</b>	<b>1 per 15</b>	<b>1 per 15</b>	<b>1 per 15</b>	<b>1 per 100</b>	<b>1</b>
	<b>I-3 Jails/reformatories cells</b>	<b>1 per cell</b>	<b>1 per cell</b>	<b>1 per 8</b>	<b>--</b>	<b>--</b>
	<b>I-3 Dormitory or other institutional rooms with 24 hour access to sanitary facilities</b>	<b>1 per 12      1 per 8</b>	<b>1 per 12</b>	<b>1 per 8</b>	<b>--</b>	<b>--</b>
	<b>I-3 Exercise rooms</b>	<b>1 per room</b>	<b>1 per room</b>	<b>--</b>	<b>--</b>	<b>--</b>
	<b>I-3 Employees (c)</b>	<b>1 per 25</b>	<b>1 per 25</b>	<b>--</b>	<b>1 per 100</b>	<b>--</b>
	<b>I-3 Visitors</b>	<b>1 per 75</b>	<b>1 per 100</b>	<b>--</b>	<b>1 per 500</b>	<b>--</b>
<b>R</b>	<b>Lodges, dormitories, and bed and breakfast facilities</b>	<b>1 per 10</b>	<b>1 per 8</b>	<b>1 per 10</b>	<b>1 per 100</b>	<b>1</b>
	<b>Hotels and motels</b>	<b>1 per guest room</b>	<b>1 per guest room</b>	<b>1 per guest room</b>	<b>--</b>	<b>1</b>
	<b>Multiple family housing (d)</b>	<b>1 per dwelling unit</b>	<b>1 per dwelling unit</b>	<b>1 per dwelling unit</b>	<b>--</b>	<b>1 kitchen sink per dwelling unit</b>

**Note (a)** The fixtures shown are based on one (1) fixture being the minimum required for the number of persons indicated or any fraction of the number of persons indicated.

**Note (b)** Fixtures located in adjacent buildings under the ownership or control of the church may be made available during periods the church is occupied.

**Note (c)** Toilet facilities for employees shall be separate from the facilities for inmates or patients.

**Note (d)** One (1) automatic clothes washer connection shall be required per twenty (20) dwelling units.

**Note (e)** One (1) automatic clothes washer connection shall be required per dwelling unit.

**Note (f)** A single-occupant toilet room and one (1) water closet and one (1) lavatory servicing not more than two (2) adjacent patients rooms shall be permitted where such room is provided with direct access from each patient room and with provisions for privacy.

**Note (g)** For nurseries, a maximum of one (1) bathtub shall be required.

*(Fire Prevention and Building Safety Commission; 675 IAC 13-2.4-223)*



**675 IAC 13-2.4-224 Section 3001.2; referenced standards**

Authority: IC 22-13-2-2; IC 22-13-2-13  
Affected: IC 22-12; IC 22-13; IC 22-14; IC 22-15; IC 36-7

**Sec. 224. Change Section 3001.2 Referenced standards to read as follows: Except as otherwise provided for in this code, the design, construction, installation and alteration of elevators and conveying systems that are part of a Class 1 structure shall conform to the Indiana Elevator Safety Code (675 IAC 21).** *(Fire Prevention and Building Safety Commission; 675 IAC 13-2.4-224)*

**675 IAC 13-2.4-225 Section 3001.3; accessibility**

Authority: IC 22-13-2-2; IC 22-13-2-13  
Affected: IC 22-12; IC 22-13; IC 22-14; IC 22-15; IC 36-7

**Sec. 225. Change Section 3001.3 Accessibility to read as follows: See Chapter 11 for the requirements for accessible elevators.** *(Fire Prevention and Building Safety Commission; 675 IAC 13-2.4-225)*

**675 IAC 13-2.4-226 Section 3001.4; change in use**

Authority: IC 22-13-2-2; IC 22-13-2-13  
Affected: IC 22-12; IC 22-13; IC 22-14; IC 22-15; IC 36-7

**Sec. 226. Change Section 3001.4 Change in use to read as follows: See the Indiana Elevator Safety Code (675 IAC 21) for any change of use of an elevator.** *(Fire Prevention and Building Safety Commission; 675 IAC 13-2.4-226)*

**675 IAC 13-2.4-227 Section 3002.4.1**

Authority: IC 22-13-2-2; IC 22-13-2-13  
Affected: IC 22-12; IC 22-13; IC 22-14; IC 22-15; IC 36-7

**Sec. 227. Add Section 3002.4.1 after Section 3002.4 to read as follows: 3002.4.1 Elevator car to accommodate ambulance stretcher in building three stories or less in height. In buildings of I-1, I-2, I-3, and R-4 occupancies that are three stories or less in height, where an elevator is installed, such elevator shall be installed in accordance with the provisions in Section 3002.4.** *(Fire Prevention and Building Safety Commission; 675 IAC 13-2.4-227)*

**675 IAC 13-2.4-228 Section 3005.3; conveyors**

Authority: IC 22-13-2-2; IC 22-13-2-13  
Affected: IC 22-12; IC 22-13; IC 22-14; IC 22-15; IC 36-7

**Sec. 228. Change Section 3005.3 Conveyors to read as follows: Conveyors and conveying systems that are within the scope of Section 101.2 shall comply with ASME B20.1 and Sections 300.3.1 and 300.3.2.** *(Fire Prevention and Building Safety Commission; 675 IAC 13-2.4-228)*

**675 IAC 13-2.4-229 Section 3103.1.1; permit required**

Authority: IC 22-13-2-2; IC 22-13-2-13  
Affected: IC 22-12; IC 22-13; IC 22-14; IC 22-15; IC 36-7

**Sec. 229. Delete Section 3103.1.1 Permit required and**

**Section 3103.2 Construction documents and substitute as follows: See the General Administrative Rules (675 IAC 12-6) and local ordinance.** *(Fire Prevention and Building Safety Commission; 675 IAC 13-2.4-229)*

**675 IAC 13-2.4-230 Section 3107.1; general**

Authority: IC 22-13-2-2; IC 22-13-2-13  
Affected: IC 22-12; IC 22-13; IC 22-14; IC 22-15; IC 36-7

**Sec. 230. Delete Section 3107.1 General.** *(Fire Prevention and Building Safety Commission; 675 IAC 13-2.4-230)*

**675 IAC 13-2.4-231 Section 3109; swimming pool enclosure**

Authority: IC 22-13-2-2; IC 22-13-2-13  
Affected: IC 22-12; IC 22-13; IC 22-14; IC 22-15; IC 36-7

**Sec. 231. Delete Section 3109 Swimming pool enclosures and substitute as follows: See the Indiana Swimming Pool Code (675 IAC 20).** *(Fire Prevention and Building Safety Commission; 675 IAC 13-2.4-231)*

**675 IAC 13-2.4-232 Chapter 32; encroachments into the public right-of-way**

Authority: IC 22-13-2-2; IC 22-13-2-13  
Affected: IC 22-12; IC 22-13; IC 22-14; IC 22-15; IC 36-7

**Sec. 232. Delete Chapter 32 Encroachments into the public right-of-way and substitute as follows: See local ordinance.** *(Fire Prevention and Building Safety Commission; 675 IAC 13-2.4-232)*

**675 IAC 13-2.4-233 Chapter 33; safeguards during construction**

Authority: IC 22-13-2-2; IC 22-13-2-13  
Affected: IC 22-12; IC 22-13; IC 22-14; IC 22-15; IC 36-7

**Sec. 233. Delete Chapter 33 Safeguards during construction.** *(Fire Prevention and Building Safety Commission; 675 IAC 13-2.4-233)*

**675 IAC 13-2.4-234 Chapter 34; existing structures**

Authority: IC 22-13-2-2; IC 22-13-2-13  
Affected: IC 22-12; IC 22-13; IC 22-14; IC 22-15; IC 36-7

**Sec. 234. Delete Chapter 34 Existing structures and substitute as follows: See the General Administrative Rules (675 IAC 12) and local ordinance.** *(Fire Prevention and Building Safety Commission; 675 IAC 13-2.4-234)*

**675 IAC 13-2.4-235 Chapter 35; referenced standards**

Authority: IC 22-13-2-2; IC 22-13-2-13  
Affected: IC 22-12; IC 22-13; IC 22-14; IC 22-15; IC 36-7

**Sec. 235. Change in the first paragraph of Chapter 35 Referenced Standards "Section 102.8" to "Section 101.3".** *(Fire Prevention and Building Safety Commission; 675 IAC 13-2.4-235)*

---

---

## Proposed Rules

---

---

### 675 IAC 13-2.4-236 APPENDICES

Authority: IC 22-13-2-2; IC 22-13-2-13

Affected: IC 22-12; IC 22-13; IC 22-14; IC 22-15; IC 36-7

**Sec. 236. Make the following changes:**

- (1) Delete Appendix A Employee Qualifications.
- (2) Delete Appendix B Board of Appeals.
- (3) Delete Appendix C Group U Agricultural Buildings.
- (4) Delete Appendix D Fire Districts.
- (5) Delete Appendix E Supplementary Accessibility Requirements.
- (6) Delete Appendix F Rodent Proofing.
- (7) Delete Appendix G Flood Resistant Construction.
- (8) Delete Appendix H Signs.
- (9) Delete Appendix J Supplementary Accessibility Requirements for Qualified Historic Buildings and Facilities.

*(Fire Prevention and Building Safety Commission; 675 IAC 13-2.4-236)*

SECTION 2. 675 IAC 13-2.3 IS REPEALED.

#### **Notice of Public Hearing**

*Under IC 4-22-2-24, notice is hereby given that on September 16, 2002 at 10:00 a.m., at the Indiana Government Center-South, 402 West Washington Street, Conference Center Room C, Indianapolis; AND on November 6, 2002 at 10:00 a.m., at the Indiana Government Center-South, 402 West Washington Street, Conference Center Room B, Indianapolis, Indiana the Fire Prevention and Building Safety Commission will hold a public hearing on proposed amendments to the Indiana Building Code, 2003 Edition, which adopts, with Indiana amendments, the 2000 International Building Code. Copies of these rules are now on file at the Indiana Government Center-South, 402 West Washington Street, Room W246 and Legislative Services Agency, One North Capitol, Suite 325, Indianapolis, Indiana and are open for public inspection.*

Patrick Ralston  
Secretary  
Fire Prevention and Building Safety Commission

---

---

## TITLE 675 FIRE PREVENTION AND BUILDING SAFETY COMMISSION

### Proposed Rule

LSA Document #02-116

### DIGEST

Adds 675 IAC 18-1.4, which adopts and amends the 2000 International Mechanical Code as the 2003 Indiana Mechanical Code. Repeals 675 IAC 18-1.3. Effective 30 days after filing with the secretary of state.

### 675 IAC 18-1.3

### 675 IAC 18-1.4

SECTION 1. 675 IAC 18-1.4 IS ADDED TO READ AS FOLLOWS:

#### **Rule 1.4. Indiana Mechanical Code, 2003 Edition**

#### **675 IAC 18-1.4-1 Adoption by reference; title; availability; scope; purpose**

Authority: IC 22-13-2-2

Affected: IC 22-12; IC 22-13; IC 22-14; IC 22-15; IC 36-7-2-9

**Sec. 1. (a)** That certain document being titled the International Mechanical Code, third printing, published by the International Code Council, 5203 Leesburg Pike, Suite 708, Falls Church, Virginia 22041-3401, is hereby adopted by reference as if fully set out in this rule save and except those revisions made in this rule.

**(b)** This rule is available for review and reference at the Fire and Building Services Department, Indiana Government Center-South, 402 West Washington Street, Room W246, Indianapolis, Indiana 46204. *(Fire Prevention and Building Safety Commission; 675 IAC 18-1.4-1)*

#### **675 IAC 18-1.4-2 Chapter 1; administration**

Authority: IC 22-13-2-2

Affected: IC 4-21-5; IC 22-12-7; IC 22-13-2-7; IC 22-13-5; IC 22-14; IC 22-15; IC 36-7-2-9

**Sec. 2. Delete Chapter 1 and substitute to read as follows:**

#### **Section 101 Application**

##### **101.1 Title**

This rule shall be known as the Indiana Mechanical Code, 2003 edition and shall be published, except incorporated documents, by the fire and building services department, for general distribution and use under that title. Wherever the term "this code" is used throughout this rule, it shall mean the Indiana Mechanical Code, 2003 edition.

##### **101.2 Scope and purpose**

The scope and purpose of this code is to establish the minimum requirements for the following:

1. Construction, addition, alteration, erection or assembly of any part of a Class 1 structure at the site where the structure will be used.
2. Installation of any part of the permanent heating, ventilating, air conditioning, electrical, plumbing, sanitary, emergency detection, emergency communication, or fire or explosion suppression systems for a Class 1 structure at the site where it will be used.
3. Work undertaken to alter, remodel, rehabilitate, or add to any part of a Class 1 structure.

4. Safeguarding life or property from the hazards of fire and explosion for Class 1 structures.
5. Fabrication of any part of a Class 1 industrialized building system for installation, assembly, or use at another site, except mobile structures.
6. Work undertaken to relocate any part of a Class 1 structure, except a mobile structure.
7. Assembly of a Class 1 industrialized building system that is not covered by subdivision 5, except mobile structures.
8. Detached one and two family dwellings and townhouses not more than three stories high and their accessory structures shall comply with the Indiana Residential Code, 675 IAC 14.

### 101.3 Appendices and Standards

Provisions in the appendices are not enforceable unless specifically adopted.

The codes and standards referenced in this code shall be considered part of the requirements of this code to the prescribed extent of each such reference. Where differences occur between provisions of this code and referenced codes and standards, the provisions of this code shall apply.

**EXCEPTION:** Where enforcement of a code provision would violate the conditions of the listing, labeling or manufacturer's installation instructions of the equipment, engineered wood product or appliance, the conditions of the listing, labeling or manufacturer's instructions shall apply.

### 101.4 Appeals and Interpretations

Appeals from orders issued by the Fire Prevention and Building Safety Commission, the Office of the State Building Commissioner or the Office of the State Fire Marshal are governed by IC 4-21.5 and IC 22-12-7. Appeals from orders by a local unit of government are governed by IC 22-13-2-7 and local ordinance. Upon the written request of an interested person who has a dispute with a county or municipal government concerning a building rule, the Office of the State Building Commissioner may issue a written interpretation of a building law. The written interpretation as issued under IC 22-13-5 binds the interested person and the county or municipality with whom the interested person has the dispute until overruled under IC 4-21.5. A written interpretation of a building law binds all counties and municipalities if the office of the state building commissioner publishes the written interpretation of the building law in the Indiana Register under IC 4-22.7-7(b).

### 101.5 Plans

Plans shall be submitted for Class 1 structures as required by the General Administrative Rules (675 IAC 12) and the rules for Industrialized Building Systems (675 IAC 15).

### 101.6 Existing Construction

For existing Class 1 structures, see the General Administrative Rules (675 IAC 12) and local ordinance.

### 101.7 Additions and Alterations

Additions and alterations to any Class 1 structure shall conform to that required of a new structure without requiring the existing structure to comply with all the requirements of this code. Additions or alterations shall not cause an existing structure to become unsafe (See the General Administrative Rules (675 IAC 12-4)).

### 101.8 Alternate Materials, Methods, and Equipment

Alternate materials, methods, equipment, and design shall be as required by the General Administrative Rules (675 IAC 12-6-11) and the rules for Industrialized Building Systems (675 IAC 15). (*Fire Prevention and Building Safety Commission; 675 IAC 18-1.4-2*)

### 675 IAC 18-1.4-3 Chapter 2; definitions

Authority: IC 22-13-2-2

Affected: IC 22-12; IC 22-13; IC 22-14; IC 22-15; IC 36-7-2-9

Sec. 3. In Chapter 2, make the following changes:

(a) Change the definition of **APPLIANCE-EXISTING** to read as follows: Any appliance regulated by this code which was legally installed prior to the effective date of this code.

(b) Change the definition of **APPROVED** to read as follows:

**APPROVED** as to materials, equipment, design, and types of construction, acceptance by the code official by one (1) of the following methods:

(1) investigation or tests conducted by recognized authorities; or

(2) investigation or tests conducted by technical or scientific organizations; or accepted principles.

The investigation, tests or principles shall establish that the materials, equipment and types of construction are safe for their intended purpose.

(c) Delete the definition of **BASE FLOOD ELEVATION**.

(d) Delete the definition of **CODE**.

(e) Change the definition of **CODE OFFICIAL** to read as follows: The office of the state building commissioner authorized under IC 22-15-2-7; the office of the state fire marshal authorized under IC 22-14-2-10; the local building official authorized under IC 36-7-9 and local ordinance; the fire department authorized under IC 36-8-17-9, or local ordinance.

(f) Change the definition of **COMMERCIAL FOOD HEAT-PROCESSING APPLIANCES** to read as follows: Appliances used in commercial cooking operations, and which produce grease vapors, steam fumes, smoke or

---

## Proposed Rules

---

odors that are required to be removed through a local exhaust ventilation system.

(g) Delete the definition of COMPENSATING HOODS.

(h) Delete the definition of CONSTRUCTION DOCUMENTS and substitute as follows: See the General Administrative Rules (675 IAC 12-6) and the rules for Industrialized Building Systems (675 IAC 15).

(i) Change the definition of EQUIPMENT, EXISTING to read as follows: Any equipment regulated by this code which was legally installed prior to the effective date of this code.

(j) Add the definition for FIRE PREVENTION CODE to read as follows:

**FIRE PREVENTION CODE.** See the INDIANA BUILDING CODE (675 IAC 13) and the INDIANA FIRE CODE (675 IAC 22).

(k) Delete the definition of FLOOD ZONES.

(l) Delete the definition of HOOD and substitute to read as follows: See Section 506 of this code.

(m) Change the definition of IMMEDIATELY DANGEROUS TO LIFE OR HEALTH (IDLH) to read as follows: The concentration of airborne contaminants that poses a threat of death, immediate or delayed permanent adverse health effects, or effects that could prevent escape from such an environment.

(n) Add the following definitions after the definition of INDIRECT REFRIGERATION SYSTEM and before the definition of JOINT, FLANGED:

(1) ICC ELECTRICAL CODE means the INDIANA ELECTRICAL CODE (675 IAC 17).

(2) ICC BUILDING CODE means the INDIANA BUILDING CODE (675 IAC 13).

(3) INTERNATIONAL BUILDING, FIRE, FUEL GAS, PLUMBING, and ENERGY CONSERVATION CODES mean the INDIANA BUILDING, FIRE, FUEL GAS, PLUMBING, and ENERGY CONSERVATIONS CODES (675 IAC 13, 675 IAC 22, 675 IAC 25, 675 IAC 15 and 675 IAC 19).

(o) Delete the definition of LABELED and substitute to read as follows: Equipment, devices, appliances or materials to which has been attached a label, symbol, or other identifying mark of an organization engaged in product evaluation, that maintains periodic inspection of production of labeled equipment or materials and by whose labeling the manufacturer indicates compliance with appropriate standards or performance in a specified manner.

(p) Delete the definition of LISTED and substitute to read as follows: Equipment, appliances, devices, or materials included in a list published by an organization engaged in product evaluation, that maintains periodic inspection of production of listed equipment or materials and whose listing states either that the equipment or material meets appropriated standards or has been tested and found suitable for use in a specified manner.

(q) Change the definition of REGISTERED DESIGN

PROFESSIONAL to read as follows: A registered architect or professional engineer who is registered under IC 25-4 or IC 25-31. If a registered design professional is not required by the General Administrative Rules (675 IAC 12-6) or the rules for Industrialized Building Systems (675 IAC 15), then it means the owner.

*(Fire Prevention and Building Safety Commission; 675 IAC 18-1.4-3)*

### 675 IAC 18-1.4-4 Section 301.2; energy utilization

Authority: IC 22-13-2-2

Affected: IC 22-12; IC 22-13; IC 22-14; IC 22-15; IC 36-7-2-9

**Sec. 4.** In Section 301.2 Energy utilization, delete “all structures” and insert “all Class I structures”. *(Fire Prevention and Building Safety Commission; 675 IAC 18-1.4-4)*

### 675 IAC 18-1.4-5 Section 301.4; listed and labeled

Authority: IC 22-13-2-2

Affected: IC 22-12; IC 22-13; IC 22-14; IC 22-15; IC 36-7-2-9

**Sec. 5.** In Section 301.4 Listed and labeled, delete “in accordance with Section 105”. *(Fire Prevention and Building Safety Commission; 675 IAC 18-1.4-5)*

### 675 IAC 18-1.4-6 Section 301.5; labeling

Authority: IC 22-13-2-2

Affected: IC 22-12; IC 22-13; IC 22-14; IC 22-15; IC 36-7-2-9

**Sec. 6.** Delete Section 301.5 Labeling. *(Fire Prevention and Building Safety Commission; 675 IAC 18-1.4-6)*

### 675 IAC 18-1.4-7 Section 301.6; information

Authority: IC 22-13-2-2

Affected: IC 22-12; IC 22-13; IC 22-14; IC 22-15; IC 36-7-2-9

**Sec. 7.** In Item 4 of Section 301.6 Information, delete “approval” and insert “acceptance”. *(Fire Prevention and Building Safety Commission; 675 IAC 18-1.4-7)*

### 675 IAC 18-1.4-8 Section 301.13; flood hazard

Authority: IC 22-13-2-2

Affected: IC 22-12; IC 22-13; IC 22-14; IC 22-15; IC 36-7-2-9

**Sec. 8.** Delete Section 301.13 Flood hazard and substitute “See local ordinance”. *(Fire Prevention and Building Safety Commission; 675 IAC 18-1.4-8)*

### 675 IAC 18-1.4-9 Section 301.15; rodent proofing

Authority: IC 22-13-2-2

Affected: IC 22-12; IC 22-13; IC 22-14; IC 22-15; IC 36-7-2-9

**Sec. 9.** Delete Section 301.15 Rodent proofing. *(Fire Prevention and Building Safety Commission; 675 IAC 18-1.4-9)*

### 675 IAC 18-1.4-10 Section 304.1; general

Authority: IC 22-13-2-2

Affected: IC 22-12; IC 22-13; IC 22-14; IC 22-15; IC 36-7-2-9

**Sec. 10.** Change Section 304.1 General to read as follows:

Equipment and appliances shall be installed in accordance with the conditions of the listing, the manufacturer's installation instructions and this code unless otherwise approved. *(Fire Prevention and Building Safety Commission; 675 IAC 18-1.4-10)*

**675 IAC 18-1.4-11 Section 304.4; public garages**

Authority: IC 22-13-2-2  
Affected: IC 22-12; IC 22-13; IC 22-14; IC 22-15; IC 36-7-2-9

**Sec. 11.** In Section 304.4, delete "service station" and insert "motor fuel dispensing facilities". *(Fire Prevention and Building Safety Commission; 675 IAC 18-1.4-11)*

**675 IAC 18-1.4-12 Section 401.4; exists**

Authority: IC 22-13-2-2  
Affected: IC 22-12; IC 22-13; IC 22-14; IC 22-15; IC 36-7-2-9

**Sec. 12.** Change Item 3 in Section 401.4 Exits as follows: Add the words "by the Indiana Building Code" to item 3 of this section following the words "as required". *(Fire Prevention and Building Safety Commission; 675 IAC 18-1.4-12)*

**675 IAC 18-1.4-13 Section 401.7; contaminant sources**

Authority: IC 22-13-2-2  
Affected: IC 22-12; IC 22-13; IC 22-14; IC 22-15; IC 36-7-2-9

**Sec. 13.** Delete Section 401.7 Contaminant sources. *(Fire Prevention and Building Safety Commission; 675 IAC 18-1.4-13)*

**675 IAC 18-1.4-14 Section 406.1; general**

Authority: IC 22-13-2-2  
Affected: IC 22-12; IC 22-13; IC 22-14; IC 22-15; IC 36-7-2-9

**Sec. 14.** Delete Section 406.1 General and insert the following: Uninhabited spaces, such as crawl spaces and attics shall be provided with natural ventilation openings as required by the Indiana Building Code (675 IAC 13). *(Fire Prevention and Building Safety Commission; 675 IAC 18-1.4-14)*

**675 IAC 18-1.4-15 Section 501.1; scope**

Authority: IC 22-13-2-2  
Affected: IC 22-12; IC 22-13; IC 22-14; IC 22-15; IC 36-7-2-9

**Sec. 15.** Change Section 501.1 Scope to read as follows: This chapter shall govern the design, construction and installation of mechanical exhaust systems within the scope of Section 101.2, including dust stock and refuse conveyor systems and exhaust systems serving appliances used for commercial cooking operations. *(Fire Prevention and Building Safety Commission; 675 IAC 18-1.4-15)*

**675 IAC 18-1.4-16 Section 501.2; independent systems required**

Authority: IC 22-13-2-2  
Affected: IC 22-12; IC 22-13; IC 22-14; IC 22-15; IC 36-7-2-9

**Sec. 16.** Change Section 501.2 Independent system required to read as follows: Single or combined mechanical

exhaust systems from bath, toilet, urinal, locker, service sink closets and similar rooms shall be independent of all other systems. Type I exhaust systems shall be independent of all other exhaust systems, single or combined. Type II exhaust systems for food-processing operations shall be independent of all other exhaust systems. Kitchen exhaust systems shall be constructed in accordance with Section 505 for domestic equipment and Section 506 for commercial equipment. *(Fire Prevention and Building Safety Commission; 675 IAC 18-1.4-16)*

**675 IAC 18-1.4-17 Section 501.3; outdoor discharge**

Authority: IC 22-13-2-2  
Affected: IC 22-12; IC 22-13; IC 22-14; IC 22-15; IC 36-7-2-9

**Sec. 17.** Delete Section 501.3 Outdoor discharge and insert the following: The air removed by every mechanical exhaust system shall discharge to the atmosphere. The termination point for exhaust ducts discharging to the atmosphere shall be not less than the following:

- (1) Ducts conveying explosive or flammable vapors, fumes, or dusts: 30 feet from property line; 10 feet from openings into the building; 6 feet from exterior walls or roofs; 30 feet from combustible walls or openings into the building which are in the direction of the exhaust discharge; or 10 feet above adjoining grade.
- (2) Other product-conveying outlets; 10 feet from property line; 3 feet from exterior wall or roof; 10 feet from openings into the building; or 10 feet above adjoining grade.
- (3) Environmental air duct exhaust: 3 feet from property line; or 3 feet from openings into the building.

Air shall not be exhausted into an attic or crawl space. *(Fire Prevention and Building Safety Commission; 675 IAC 18-1.4-17)*

**675 IAC 18-1.4-18 Section 501.4; pressure equalization**

Authority: IC 22-13-2-2  
Affected: IC 22-12; IC 22-13; IC 22-14; IC 22-15; IC 36-7-2-9

**Sec. 18.** Delete Section 501.4 Pressure equalization and insert the following: Mechanical exhaust systems shall be sized to remove the quantity of the air required by this code. The system shall operate when air is required to be exhausted. Where mechanical exhaust is required in a room or space in other occupancies in Use Group R-2 and R-3 as defined by the Indiana Building Code (675 IAC 13), such space shall be maintained with a neutral or negative pressure. If a greater quantity of air is supplied by a mechanical ventilating supply system that is removed by a mechanical exhaust system from a room, an approved means shall be provided for the natural exit of the excess air supplied. If only a mechanical exhaust system is installed for a room or if a greater quantity of air is removed by a mechanical exhaust system, than is supplied by a mechanical ventilating supply system for a room, an approved means shall be provided for the natural supply of the

## Proposed Rules

deficiency in the air supplied. (*Fire Prevention and Building Safety Commission; 675 IAC 18-1.4-18*)

**675 IAC 18-1.4-19 Section 502.8.11; silane gas**

Authority: IC 22-13-2-2

Affected: IC 22-12; IC 22-13; IC 22-14; IC 22-15; IC 36-7-2-9

Sec. 19. Change the third line of Section 502.8.11 Silane gas to read as follows: "ing the maximum allowable quantities per control area as required by the Indiana Building Code (675 IAC 13) shall". (*Fire Prevention and Building Safety Commission; 675 IAC 18-1.4-19*)

**675 IAC 18-1.4-20 Section 502.9.1; where required**

Authority: IC 22-13-2-2

Affected: IC 22-12; IC 22-13; IC 22-14; IC 22-15; IC 36-7-2-9

Sec. 20. Delete the second sentence of Item 1 in Section 502.9.1 Where required. (*Fire Prevention and Building Safety Commission; 675 IAC 18-1.4-20*)

**675 IAC 18-1.4-21 Section 502.15.1; design**

Authority: IC 22-13-2-2

Affected: IC 22-12; IC 22-13; IC 22-14; IC 22-15; IC 36-7-2-9

Sec. 21. Change Section 502.15.1 Design to read as follows: Revise the fifth line of Item 1 to read: "25 percent of the LFL. In all cases, the sys-". (*Fire Prevention and Building Safety Commission; 675 IAC 18-1.4-21*)

**675 IAC 18-1.4-22 Section 506, Section 507, Section 508 and Section 509; commercial kitchen grease ducts and exhaust equipment, commercial kitchen hoods, commercial kitchen makeup air, and fire suppression systems**

Authority: IC 22-13-2-2

Affected: IC 22-12; IC 22-13; IC 22-14; IC 22-15; IC 36-7-2-9

Sec. 22. Delete Section 506 Commercial kitchen grease ducts and exhaust equipment; Section 507 Commercial kitchen hoods; Section 508 Commercial kitchen makeup air; and Section 509 Fire suppression systems and insert the following: 506.1.1 For the purposes of this section, the following definitions shall apply:

\***AIR POLLUTION CONTROL DEVICES.** Equipment and devices used for the purpose of cleaning air passing through or by them in such a manner as to reduce or remove the impurities contained therein.\*

\***COMBUSTIBLE MATERIAL.** Material subject to increase in combustibility or flame spread rating beyond the limits established in the definition of limited-combustible.

**CONTINUOUS EXTERNAL WELD.** A metal joining method without interruption as related to visibility and quality, located on the outside of the surfaces that directly contain and/or convey the grease-laden vapors of the cooking process(es). For the purpose of this definition, it

specifically includes the exhaust compartment of hoods and welded joints of exhaust ducts, yet specifically does not include filter support frames or appendages inside hoods.

**DAMPER.** A valve or plate within a duct or its terminal components for controlling draft or the flow of gases, including air.

**DUCTS (or Duct System).** A continuous passageway for the transmission of air and vapors that, in addition to the containment components themselves, may include duct fittings, dampers, plenums, and/or other items or air handling equipment.

**FUME INCINERATORS.** Devices utilizing intense heat or fire to break down and/or oxidize vapors and odors contained in gases or air being exhausted into the atmosphere.

**GREASE.** Rendered animal fat, vegetable shortening, and other such oily matter used for the purposes of and resulting from cooking and/or preparing foods. Grease may be liberated and entrained with exhaust air, or may be visible as a liquid or solid.

**GREASE DUCTS.** A containment system for the transportation of air and grease vapors, designed and installed to reduce the possibility of the accumulation of combustible condensation and the occurrence of damage should a fire occur within the system.

**GREASE FILTER.** A component of the grease vapor removal system that deflects the air and vapors passing through it in a manner that causes the grease vapor concentration and/or condensation for the purpose of collection, leaving the exiting air with a lower amount of combustible matter.

**GREASE REMOVAL DEVICES.** Other components of the grease and vapor removal system that do not fit the definition of grease filter yet are designed, installed, and perform by removing vapor suspended grease particles from the exhaust air/vapor stream or are designed to assist other devices in the removal of such vapors or particles.

**GREASE TIGHT.** Constructed and performing in such a manner as not to permit the passage of any grease under normal cooking conditions.\*

**HOOD** is an air-intake device connected to a mechanical exhaust system for collecting and removing grease, vapors, fumes, smoke, steam, heat, or odors from commercial food heat-processing equipment.

**TYPE I HOOD** is a kitchen hood for collecting and removing grease and smoke.

**TYPE II HOOD** is a general kitchen hood for collecting and removing steam, vapor, heat, or odors.

**CANOPY HOOD** means a hood located above the cooking equipment it serves and which overhangs equipment on all open sides.

**COMPENSATING HOOD** is a hood that has an outside air supply with air delivered below or within the hood.

When makeup air is diffused directly into the exhaust within the hood cavity, it becomes a short-circuit hood.

**\*LABELED.** Equipment or materials to which has been attached a label, symbol, or other identifying mark of an organization engaged in product evaluation, that maintains periodic inspection of production of labeled equipment or materials and by whose labeling the manufacturer indicates compliance with appropriate standards or performance in a specified manner.

**LIMITED-COMBUSTIBLE.** As applied to a building construction material, a material, not complying with the definition of noncombustible material, that, in the form in which it is used, has a potential heat value not exceeding three thousand five hundred (3,500) Btu per pound and complies with one (1) of the following paragraphs (a) or (b). Materials subject to increase in combustibility or flame spread rating beyond the limits herein established through the effects of age, moisture, or other atmospheric condition shall be considered combustible.

(a) Materials having a structural base of noncombustible material, with a surfacing not exceeding a thickness of one-eighth ( $\frac{1}{8}$ ) inch, which has a flame spread rating not greater than fifty (50).

(b) Materials, in the form and thickness used, other than as described in (a), having neither a flame spread rating greater than twenty-five (25) nor evidence of continued progressive combustion and of such composition that surfaces that would be exposed by cutting through the material on any plane would have neither a flame spread rating greater than twenty-five (25) nor evidence of continued progressive combustion.

**LIQUIDTIGHT.** Constructed and performing in such a manner as not to permit the passage of any liquid at any temperature.

**NONCOMBUSTIBLE MATERIAL.** A material that, in the form in which it is used and under the conditions anticipated, will not ignite, burn, support combustion, or release flammable vapors when subjected to fire or heat.\*

**MAKEUP AIR.** Air supplied to the room where the hood is located approximately equal to the amount of air exhausted.

**\*THERMAL RECOVERY UNIT.** A device or series of devices whose purpose is to reclaim only the heat content of air, vapors, gases, and/or fluids that were being expelled through the exhaust system and to transfer the thermal energy so reclaimed to a location whereby a useful purpose may be served.\*

**506.2 General requirements for hoods**

**506.2.1 Type I Hoods.** Commercial food heat-processing appliances used in a process that produce smoke or grease-laden vapors shall be equipped with an exhaust system complying with Type I Hood requirements.

**506.2.2 Type II Hoods.** Commercial food heat-processing appliances producing steam or heat that does not generate smoke or grease-laden vapors such as dishwashing

machines shall be equipped with an exhaust system complying with Type II Hood requirements.

**506.2.3 Solid Fuel.** All commercial food heat-processing appliances using solid fuel shall be served by a separate exhaust system that complies with Type I Hood requirements.

**506.2.4 Alteration, Replacement, Relocation.** Notification in writing shall be given to the code official of any alteration, replacement, or relocation of any exhaust system equipment, exhaust system, extinguishing equipment, or any part thereof.

**506.2.5 Alternates.** Alternate materials, methods, and design shall be in accordance with the General Administrative Rules, 675 IAC 12-6-11.

**506.3 Type I exhaust hood construction**

**506.3.1 \*Materials.** The hood or that portion of a primary collection means designed for collecting cooking vapors and residues shall be constructed of and be supported by steel not less than forty-three thousandths (0.043) inch (No. 18 Mean Steel Gage) or stainless steel not less than thirty-seven thousandths (0.037) inch (No. 20 Mean Steel Gage) in thickness, or of other approved materials of equivalent strength, fire resistance, and corrosion resistance.\* Hoods of copper shall be of copper sheets weighing at least twenty-four (24) ounces per square foot.

**506.3.2 Painting or Coating.** Surfaces that come into contact with food, and surfaces from which food may drain, drip, or be subjected to splash, spillage, or other food soiling shall:

- (1) not impart toxic substances, odor, color, or taste to food;
- (2) be smooth and cleanable;
- (3) be corrosion-resistant with a material that is noncracking and nondripping; and
- (4) not be coated with a lead based coating.

**506.3.3 Seams, Joints.** All seams, joints, and penetrations of the hood enclosure that directs and captures grease-laden vapors and exhaust gases, to its lower outermost perimeter of the entire hood assembly shall have a liquidtight continuous external weld or be sealed by labeled devices. Internal hood joints, seams, filter support frames, and appendages attached inside the hood need not be welded but shall be sealed or otherwise be made greasetight. All materials used to seal interior joints shall be labeled.

**506.3.4 Insulation.** Insulation materials other than electrical insulation shall be identified as having a flame spread rating of twenty-five (25) or less when tested in accordance with ASTM E84.

**506.3.5 Hood Size and Location.** For canopy type hoods, the inside edge of the hood shall overhang or extend a horizontal distance of not less than six (6) inches beyond the edge of the cooking surface on all exposed sides, and the vertical distance between the lip of the hood and the cooking surface shall not exceed four (4) feet.

## Proposed Rules

Hoods of the noncanopy or backshelf types shall be located a maximum of three (3) feet above the cooking surface. The inside edge of the hood shall overhang or extend a horizontal distance of not less than three (3) inches beyond the edge of the cooking surface on exposed ends. The front edge of the hood shall be set back a maximum of twelve (12) inches from the edge of the cooking surface.

**506.3.6 Labeled Hoods.** Labeled hood assemblies shall be considered as complying with this chapter and shall be installed in accordance with the conditions of labeling and the manufacturer's instructions.

**506.4 Exhaust hood assemblies with integrated supply air plenums**

**506.4.1 General.** The construction and size of the hood shall comply with the requirements of subsection 506.3.

**506.4.2 \*Supply Fire Dampers.** A fire damper shall be installed in the supply air plenum at each point where a supply air duct inlet or a supply air outlet penetrates the continuously welded shell of the assembly. The damper shall be constructed of at least the same gage as the shell. The actuation device of the damper shall have a maximum rating of two hundred eighty-six degrees Fahrenheit (286°F). Supply air plenums that discharge air from their face rather than from the bottom or into the exhaust hood and that are isolated from the exhaust hood by the continuously welded shell extending to the lower outermost perimeter of the entire hood assembly do not require a fire damper.\*

**506.4.3 Exhaust Fire Dampers.** Fire dampers shall not be installed in an exhaust hood assembly.

**EXCEPTION:** Labeled hood assemblies with exhaust dampers shall be permitted.

**506.4.4 Labeled Hood Assemblies.** Labeled hood assemblies shall be installed in accordance with the conditions of the labeling and the manufacturer's instructions.

**506.5 Grease removal devices in hoods**

**506.5.1 \*Grease Removal Devices.** Labeled grease filters, baffles, or other approved grease removal devices for use with commercial cooking equipment shall be provided for Type I hoods. Mesh filters shall not be used.

**506.5.2 Installations.** The distance between the grease removal device and the cooking surface shall be as great as possible. Where grease removal devices are used in conjunction with charcoal or charcoal-type broilers, including gas or electrically heated charbroilers, a minimum vertical distance of four (4) feet shall be maintained between the lower edge of the grease removal device and the cooking surface.

**EXCEPTIONS:** 1. Grease removal devices supplied as part of labeled hood assemblies shall be installed in accordance with the terms of the labeling and the manufacturer's instructions.

2. For cooking equipment without exposed flame and where fire gases bypass grease removal devices, the

minimum vertical distance may be reduced to not less than six (6) inches.\*

**506.5.3 Protection.** Grease removal devices shall be protected from combustion gas outlets and from direct flame impingement where the distance between the grease removal device and the appliance flue outlet (heat source) is less than eighteen (18) inches. This protection may be accomplished by the installation of a steel or stainless steel baffle plate between the heat source and the grease removal device. The baffle plate shall be so sized and located that flames or combustion gases must travel a distance not less than eighteen (18) inches from the heat source to the grease removal device.

**EXCEPTION:** See Exceptions No. 1 and No. 2 to subsection 506.5.2.

**506.5.4 \*Filters.** Filters shall be tight-fitting and firmly held in place, and shall be readily accessible and removable for cleaning. Filters shall be installed at an angle not less than forty-five (45) degrees from the horizontal. Filters shall be equipped with a drip tray beneath the lower edge of the filters. The tray shall be kept to the minimum size needed to collect the grease and be pitched to drain to an enclosed metal container having a capacity not exceeding one (1) gallon.\*

**506.6 Type II exhaust hood construction**

**506.6.1 Materials.** Type II hoods shall be constructed of galvanized steel, stainless steel, copper, twenty-four thousandths (0.024) inch (No. 24 gage) steel, or other approved material.

Hoods constructed of copper shall be of copper sheets weighing at least twenty-four (24) ounces per square foot. Hoods constructed of stainless steel shall have a minimum thickness of thirty-thousandths (0.030) inch.

**506.6.2 Fabrication and Installation.** Hoods shall be secured in place by noncombustible supports. Joints and seams shall be substantially tight. Solder shall not be used except for sealing a joint or seam.

**506.6.3 Painting and Coating.** Surfaces that come into contact with food, and surfaces from which food may drain, drip, or be subjected to splash, spillage, or other food soiling shall:

- (1) not impart toxic substances, odor, color, or taste to food;
- (2) be smooth and cleanable;
- (3) be corrosion-resistant with a material that is noncracking and nondripping; and
- (4) not be coated with a lead based coating.

**506.6.4 Hood size and location.** For canopy type hoods, the inside edge of the hood shall overhang or extend a horizontal distance of not less than six (6) inches beyond the edge of the cooking surface or equipment served on all exposed sides, and the vertical distance between the lip of the hood and the cooking surface or equipment served shall not exceed four (4) feet.

Hoods of noncanopy or backshelf types shall be located a



maximum of three (3) feet above the cooking surface or equipment served. The inside edge of the hood shall overhang or extend a horizontal distance of not less than three (3) inches beyond the edge of the cooking surface or equipment served on exposed ends. The front edge of the hood shall be set back a maximum of twelve (12) inches from the edge of the cooking surface or equipment served.

**506.7 Air movement**

**506.7.1 Makeup Air.** Each room provided with an exhaust system required by this chapter shall have filtered air supplied to the room approximately equal to the amount of air to be exhausted and shall be adequate to prevent a negative pressure in the commercial cooking areas from exceeding two-hundredths (0.02) inch of water column. Windows and doors shall not be used for the purpose of supplying makeup air.

The makeup air shall not reduce the temperature of the occupied space to less than sixty-five degrees Fahrenheit (65°F) at five (5) feet above the floor throughout the room.

**506.7.2 Compensating Hoods.** Compensating hoods shall extract at least fifty percent (50%) of the required air flow from the kitchen area.

**EXCEPTION:** Labeled hoods that are installed in accordance with the conditions of the labeling and the manufacturer's instructions.

**506.7.3 Capacity of Canopy Hoods.** Canopy-type cooking hoods shall exhaust through the hood a minimum quantity of air determined by application of the formulas in items 1 through 4 below:

- WHERE:**
- A = the horizontal surface area of the hood, in square feet.
  - P = that part of the perimeter of the hood that is open, in feet.
  - D = distance in feet between the lower lip of the hood and the cooking surface.
  - Q = quantity of air, in cubic feet per minute.

When cooking equipment is installed back-to-back and is covered by a common island-type hood, the airflow required may be calculated using the formula for three (3) sides exposed. When all appliances are electric, the airflow required may be reduced to eighty percent (80%) of the formula value. Type II hood airflow requirements shall be in accordance with item 4 below:

1. Type I hoods for use over charcoal and other solid-fuel charbroilers shall be provided with separate exhaust systems. Undefined cooking equipment other than charcoal and solid-fuel charbroilers may be installed under a common hood. The minimum airflow for charcoal, solid-fuel, and grease-burning charbroilers and undefined equipment shall be:

Number of Exposed Sides	Formula
4 (island or central hood)	Q = 300A
3 or less	Q = 200A
Alternate formula	Q = 100PD

2. Type I hoods when the cooking equipment includes appliances such as deep-fat fryers:

Number of Exposed Sides	Formula
4 (island or central hood)	Q = 150A
3 or less	Q = 100A
Alternate formula	Q = 100PD

3. Type I hoods where the cooking equipment includes appliances such as rotisseries, grills, and ranges:

Number of Exposed Sides	Formula
4 (island or central hood)	Q = 100A
3 or less	Q = 75A
Alternate formula	Q = 50PD

4. Type I hoods where the cooking equipment includes appliances such as ranges, roasters, roasting ovens, pastry ovens, and equipment approved for use under a Type II hood, such as pizza ovens. Solid-fuel ovens shall be provided with separate exhaust systems:

Number of Exposed Sides	Formula
4 (island or central hood)	Q = 75A
3 or less	Q = 50A
Alternate formula	Q = 50PD

**EXCEPTION:** Labeled exhaust hoods are to be installed in accordance with the conditions of labeling and the manufacturer's instructions.

**506.7.4 Capacity of Noncanopy Hoods.** In addition to all other requirements for hoods specified in this section, the volume of air exhausting through noncanopy-type hoods to the duct system shall be not less than three hundred (300) cubic feet per minute per lineal foot of hood.

**EXCEPTION:** Labeled exhaust hoods installed in accordance with the conditions of labeling and the manufacturer's instructions.

**506.7.5 Exhaust Duct Velocity.** The exhaust velocity for duct systems serving Type I hoods shall not be less than one thousand five hundred (1,500) cubic feet per minute.

**506.8 Duct systems**

**506.8.1 Materials.** Grease ducts and plenums serving a Type I hood shall be constructed of at least fifty-five thousandths (0.055) inch thick (No. 16 manufacturer's standard gage) steel or stainless steel at least forty-four thousandths (0.044) inch in thickness.

**EXCEPTION:** Labeled grease ducts installed in accordance with the conditions of labeling and the manufacturer's recommendations.

Ducts and plenums serving Type II hoods shall be constructed of rigid metallic materials as set forth in Chapter 6. Duct bracing and supports shall comply with Chapter 6. Ducts subject to positive pressure shall be sealed.

**506.8.2 Seams and Joints.** Seams and joints shall be made with a continuous liquidtight weld or braze made on the external surface of the duct system.

**EXCEPTIONS:** 1. Labeled grease ducts installed in accordance with the conditions of the label and manufacturer's recommendations.

## Proposed Rules

2. Penetrations sealed by labeled devices.
3. Duct to hood collar connections as shown below in Figure 506.8 shall be permitted.

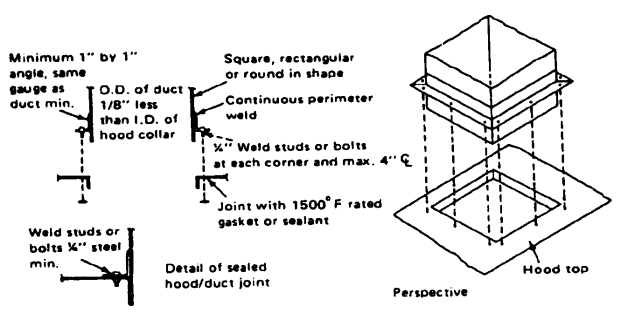

\*Figure No. 506.8

When a centrifugal fan with bottom horizontal discharge is located outside the building, a duct or duct fitting that diverts the discharge from the grease exhaust duct system in an upward direction may be connected to the fan outlet, provided the following conditions are met:

1. The duct or duct fitting shall be constructed of metal as set forth in Chapter 6 of this code.
2. The maximum total developed length of the duct or duct fitting measured along the center line shall not exceed three (3) times the vertical dimension of the fan outlet.
3. The duct or duct fitting shall be provided with openings at the lowest point to permit drainage of grease to an approved collection device that is provided with ready access.

**506.8.3 Construction.** Ducts exposed to the outside atmosphere or subject to a corrosive environment shall be protected against corrosion by galvanization of metal parts, protection with noncorrosive paints, waterproof insulation, or other approved methods of protection.

**506.8.4 Openings.** Openings for installation, servicing, and inspection of labeled fire protection system devices and duct cleaning shall be provided in ducts and enclosures. Shaft enclosure openings required to reach access panels in the ductwork shall be large enough for removal of the access panel.

Openings for installation, servicing, and inspection shall be provided at the sides or at the top of the duct, whichever is more accessible, and at changes of direction.

**EXCEPTION:** Portions of the duct that are accessible from the duct entry or discharge.

\*For labeled hoods with dampers in the exhaust collar, an access panel for cleaning and inspections shall be provided in the duct or the hood collar. This panel shall be as close to the hood as possible but not to exceed eighteen (18) inches.

Exhaust fans with ductwork connected to both sides shall

have access for cleaning and inspection within three (3) feet on each side of the fan.

Openings shall conform to the following:

1. On horizontal ducts at least one (1) twenty by twenty (20 × 20) inch opening shall be provided for personnel entry. Where an opening of this size is not possible, openings large enough to permit cleaning to bare metal shall be provided at a maximum of twelve (12) foot intervals.

2. In horizontal sections, the lower edge of the opening shall be not less than one and one-half (1½) inches from the bottom of the duct.

3. On vertical ductwork where personnel entry is possible, access shall be provided at the top of the vertical riser to accommodate descent. Where personnel entry is not possible, access for cleaning shall be provided on each floor.

4. Access panels shall be of the same material and thickness as the duct. Access panels shall have a gasket or sealant that is rated for one thousand five hundred degrees Fahrenheit (1,500°F) and shall be greasetight. Fasteners used to secure the access panels, such as bolts, weld studs, latches, or wing nuts, shall be carbon steel or stainless steel and shall not penetrate duct walls.

**EXCEPTION:** Labeled grease duct access door assemblies (access panels) shall be installed in accordance with the conditions of labeling and the manufacturer's instructions.

5. Openings for installation, servicing, and inspection of labeled fire protection system devices and duct cleaning shall be provided in ducts and enclosures.

**506.8.5 Access.** A sign shall be placed on all access panels stating:

**ACCESS PANEL—DO NOT OBSTRUCT\***

**506.8.6 Exhaust Dampers.** Exhaust dampers shall not be installed in exhaust duct systems.

**EXCEPTION:** Exhaust fire dampers shall be permitted if labeled and installed in accordance with the conditions of labeling and the manufacturer's instructions.

**506.9 Duct installation**

**506.9.1 Bracing and Supports.** Duct bracing and supports shall be of noncombustible material securely attached to the supporting structure and designed to carry gravity and lateral loads within the stress limitations of the building code. Bolts, screws, rivets, and other mechanical fasteners shall not penetrate duct walls.

**506.9.2 Prevention of Grease Accumulation.** Duct systems serving a Type I hood shall be so constructed and installed that grease cannot become pocketed in any portion thereof, and the system shall slope not less than one-fourth (¼) inch per lineal foot toward the hood or toward an approved grease reservoir. Where horizontal ducts exceed seventy-five (75) feet in length, the slope shall be not less than one (1) inch per lineal foot. When a centrifugal fan is used, it shall be positioned so the discharge

outlet is either vertical or bottom horizontal with the air so diverted that there will be no impingement on the roof, other equipment, or parts of the structure. A vertical discharge fan shall be manufactured with an approved drain outlet at the bottom of the housing to permit drainage of grease to an approved collection device that is provided with ready access.

**506.9.3 Duct Enclosure.** A grease duct serving a Type I hood which penetrates required fire-resistive construction shall be enclosed in a duct enclosure from the point of penetration. A duct shall only penetrate exterior walls at locations where unprotected openings are permitted by the building code. Duct enclosures shall be constructed as the building code requires shaft enclosures to be constructed, except that labeled duct enclosure systems conforming to the fire-resistive construction requirements of the building code for shafts shall be allowed. Duct enclosures shall be of at least one-hour fire-resistive construction and shall be of two-hour fire-resistive construction in Types I-A and II-A buildings, as defined in the building code.

**EXCEPTION:** Single story noncombustible construction where the duct does not penetrate fire-resistive construction.

The duct enclosure shall be sealed around the duct at the point of penetration of fire-resistive construction and vented to the exterior through weather-protected openings. The enclosure shall be separated from the duct by at least three (3) inches and not more than twelve (12) inches and shall serve a single grease exhaust duct system, except that labeled duct enclosure systems conforming to the fire-resistive construction requirements of the building code for shafts shall be allowed.

**506.9.4 Fire-Resistive Access Opening.** When openings are located in ducts within a fire-resistive shaft or a duct enclosure, access openings shall be provided in the shaft or duct enclosure at each opening. These access openings shall be equipped with tight-fitting sliding or hinged self-closing fire rated doors which are equal in fire-resistive protection to that of the shaft or duct enclosure. These access openings required to reach access panels in the ductwork shall be large enough to allow removal of the access panels.

**506.9.5 Duct System for Multiple Hoods.** A separate grease duct system shall be provided for each Type I hood, except that a single duct system may serve more than one (1) hood of a single business located in the same story of a building, provided that all hoods served by the system shall be located in the same room or adjoining rooms; portions of the interconnecting ducts shall not pass through any construction which would require the opening to be protected as specified in the building code.

**506.9.6 Wall Penetration.** Ducts shall not pass through area separation walls.

**506.9.7 \*Interconnection.** Duct systems shall not be

interconnected with any other building ventilating or exhaust system.

**506.9.8 Termination of Exhaust Systems.** The exhaust system shall terminate as follows:

1. Outside the building with a fan or duct; or
2. Through the roof or through a wall.

**506.9.8.1 Rooftop terminations shall be as follows:**

1. With a minimum of ten (10) feet of clearance from the outlet to adjacent buildings, property lines, and air intakes. Where space limitations absolutely prevent a ten (10) foot horizontal separation from an air intake, a vertical separation will be acceptable with the exhaust outlet being a minimum of three (3) feet above any air intake located within ten (10) feet horizontally.
2. With the exhaust flow directed up and away from the surface of the roof and a minimum of forty (40) inches above the roof surface.
3. With the ability to drain grease out of any traps or low points formed in the fan or duct near the termination of the system to a rainproof collection container or to a remote grease trap.
4. With a labeled grease duct; or
5. With a hinged up-discharge fan supplied with flexible weatherproof electrical cable and service hold-open retainer to permit proper inspection and cleaning and that is labeled for commercial cooking equipment, provided the ductwork extends a minimum of eighteen (18) inches above the roof surface, and the fan discharges a minimum of forty (40) inches above the roof surface.
6. With another approved fan, provided it conforms to subsections 506.9.8.1 item 2 and 506.9.8.1 item 3.
7. If exterior fans are located outside the roofline, they shall be provided with safe access and work surface for inspection and cleaning.

**506.9.8.2 Wall Terminations.** Wall terminations shall be as follows:

1. Through a noncombustible wall with a minimum of ten (10) foot of clearance from the outlet to adjacent buildings, property lines, grade level, combustible construction, electrical equipment or lines, and the closest point of any air intake at or below the plane of the exhaust termination. The closest point of any air intake above the plane of the exhaust termination shall be a minimum of ten (10) feet distant, plus twenty-five hundredths (0.25) foot per each one (1) degree from horizontal, the angle of degree being measured from the center of the exhaust termination to the center of the air intake.
2. With the exhaust flow directed perpendicularly outward from the wall face or upward.
3. With all the ductwork pitched to drain the grease back to the hood(s), or with a drain provided to bring the grease back to a container within the building or to a remote grease trap.
4. With a labeled grease duct.\*

## Proposed Rules

### 506.10 Exhaust fans

**506.10.1 \*Exhaust Fans for Commercial Cooking Equipment.** Approved up-discharge fans with motors surrounded by the air stream shall be hinged, supplied with flexible weatherproof electrical cable and service hold-open retainers, and labeled for this use. Other exhaust fans for this use shall be approved for continuous operation. Both shall be installed to comply with the following requirements:

1. All wiring and electrical equipment shall comply with the Indiana Electrical Code, 675 IAC 17.
2. Means shall be provided for inspections, servicing, and cleaning.\*
3. Fans manufactured from steel shall be nonsparking.

**506.10.2 \*Airflow.** The air velocity through any duct shall be not less than one thousand five hundred (1,500) feet per minute.

Exhaust air volumes for hoods shall be of sufficient level to provide for capture and removal of grease-laden cooking vapors. Test data or performance acceptable to the code official, or both, shall be provided, displayed, or both, upon request by the code official.

**EXCEPTION:** Lower exhaust air volumes shall be permitted during no-loading cooking conditions provided they are sufficient to capture and remove flue gases and residual vapors from cooking equipment.

**506.10.3 Hood Fans.** Hood exhaust fan(s) shall continue to operate after the extinguishing system has been activated unless fan shutdown is required by a labeled component of the ventilation system or by the design of the extinguishing system. It is not required to restart the hood exhaust fan when the extinguishing system is activated if the exhaust fan and all cooking equipment served by the fan had previously been shut down.\*

### 506.11 Electrical equipment

**506.11.1. Motors, lights, and other electrical devices** shall not be installed in hoods or located in the path of travel of exhaust products.

**EXCEPTION:** Where specifically labeled for such use and installed in accordance with the conditions of labeling.

\*Wiring or wiring systems shall not be installed in ducts.\* All electrical equipment shall be installed in accordance with the Indiana Electrical Code, 675 IAC 17.

### 506.12 Auxiliary equipment

**506.12.1 \*Fume incinerators, thermal recovery units, air pollution control devices, or other devices** shall be permitted to be installed in ducts or hoods or located in the path of travel of exhaust products when specifically approved under the General Administrative Rules, 675 IAC 12-6-11. The equipment shall not increase the fire hazard.\*

### 506.13 Clearance to combustibles

**506.13.1 \*Hoods and ducts** shall have a clearance of at least eighteen (18) inches to combustible material, three (3) inches to limited-combustible material, and zero (0)

inches to noncombustible material. When these clearances cannot be maintained, one (1) of the following methods shall be used:

1. When the labeled hood, duct, or duct enclosure system is installed in accordance with the provisions of its labeling and the manufacturer's instructions for reduced clearance.
2. Duct enclosures in accordance with subsection 506.9.3.
3. Combustible material protected as follows:

Type of Protection	Clearance to Combustible Material
0.013-in. (28 gage) sheet metal spaced out 1 in. on noncombustible spacers.	9 in.
0.027-in. (22 gage) sheet metal on 1 in. mineral wool bats reinforced with wire mesh or equivalent spaced out 1 in. on noncombustible spacers.*	3 in.

### 506.14 Performance test

**506.14.1** Upon completion and before final approval, if final approval is required by local ordinance, of the installation of a ventilation system serving commercial food heat-processing equipment, an air balance to verify the rate of exhaust and supply airflow shall be performed and documented.

### 506.15 Fire-extinguishing equipment

**506.15.1** Approved fire-extinguishing equipment shall be provided for the protection of all Type I hoods. Portable fire extinguishers shall be provided in the kitchen for the protection of the cooking equipment.

**506.15.2** Approved fire-extinguishing equipment shall be provided to protect cooking appliances such as deep fat fryers, griddles, upright broilers, charbroilers, grease-burning charbroilers, range tops, and grills. Protection shall also be provided for the enclosed plenum space within the hood above the filters and in the exhaust ducts serving the hood.

**506.15.3** See Section 903.2.14.2 of the Indiana Building Code.

### 506.16 Types of fire-extinguishing equipment

**506.16.1 \*Types.** Fire-extinguishing equipment shall include both fixed automatic fire-extinguishing systems and portable fire extinguishers.\*

**506.16.2 System.** The automatic fire-extinguishing system for commercial cooking systems shall be of a type recognized for protection of commercial cooking equipment and exhaust systems of the type and arrangement protected. Preengineered automatic dry- and wet-chemical extinguishing systems shall be tested in accordance with UL 300 and listed and labeled for the intended application. Other types of automatic fire-extinguishing systems shall be listed and labeled for specific use as protection

for commercial cooking operations. The system shall be installed in accordance with this code, its listing and the manufacturer's installation instructions. Other automatic fixed pipe systems shall be of an approved design and shall be one (1) of the following types:

1. Automatic sprinkler system shall be designed and installed in accordance with National Fire Protection Association Standard 13 (675 IAC 13-1-8).

2. Water spray system shall be designed and installed in accordance with National Fire Protection Association Standard 13 and 15 (675 IAC 13-1-8 and 675 IAC 22-2.2-4).

3. Carbon dioxide, dry chemical, wet chemical extinguishing systems shall be designed and installed in accordance with National Fire Protection Association Standard 12, 17, 17A, and 2001 (675 IAC 13-1-5, 675 IAC 13-1-9.5, 675 IAC 13-1-9.6, and 675 IAC 13-1-28).

**506.16.3 Dry Chemical Type.** Alkaline dry chemical-type portable fire extinguishers shall be installed in the kitchen area for the protection of the cooking equipment. Extinguishers shall have a minimum rating of forty (40) B (sodium bicarbonate or potassium bicarbonate base) and shall be conspicuously located and readily accessible along exit paths from the area. The extinguishers shall be a minimum of ten (10) feet and maximum of twenty (20) feet from the cooking equipment. The top of the extinguishers shall be a maximum of five (5) feet above the floor and shall be protected from physical damage.

**506.17 Design requirement for the fire extinguisher equipment**

**506.17.1 Chemical Systems.** The chemical used in a system shall not be substituted for the required chemical unless the substitute is labeled for that particular system, and is recommended by the manufacturer of the equipment, and is approved. Systems shall be designed on the basis of the flow and extinguishing characteristics of a specific formulation of chemical. Chemical solutions of different formulations or manufacturer shall not be mixed. A nameplate shall be permanently affixed to the control panel identifying the agent or agents labeled for use in the system.

**506.17.2 Installation Instructions.** The manufacturer's installation and maintenance manual shall be used to identify the system limitations and the applications for which chemical extinguishing systems shall be considered acceptable. Only labeled system components referenced or permitted in the manufacturer's installation and maintenance manual shall be installed as part of the system.

**506.17.3 Container Location.** Chemical containers and expellant gas assemblies shall be located within the minimum and maximum temperature range indicated in the manufacturer's installation and maintenance manual. Chemical containers and expellant gas assemblies shall not be located where they would be subjected to mechanical, chemical, or other damage.

Chemical containers and expellant gas assemblies shall be located where they are readily accessible for inspection. The top of chemical and expellant gas assemblies shall not be located more than eight (8) feet above the floor.

**506.17.4 Material.** Wherever "pipe" is used in this chapter, it shall be understood to also mean "tube". Pipe and fittings shall be of noncombustible material having physical and chemical characteristics compatible with the chemical solution. Pipe fittings shall be compatible with the piping materials and connection method.

**506.17.5 Penetrations.** Where pipe penetrates a duct or hood, the penetration shall have a liquidtight continuous external weld or shall be sealed by a labeled device.

**506.17.6 Installation.** Pipe and fittings shall be installed in accordance with the manufacturer's installation and maintenance manual. Pipe shall be reamed and cleaned before assembly. Pipe-thread compound or tape shall not be used in agent distribution pipe and fitting connections.

**EXCEPTION:** Pipe-thread tape shall be permitted when installed in accordance with the manufacturer's installation and maintenance manual.

**506.17.7 Supports.** The piping system shall be rigidly supported to prevent movement and shall be protected from mechanical or other damage.

**506.17.8 Nozzles.** Discharge nozzles shall be labeled for the purpose. All discharge nozzles shall be provided with caps or other suitable devices to prevent the entrance of grease, vapors, moisture, or other foreign materials into the piping. Nozzles shall be selected in accordance with the manufacturer's installation and maintenance manual.

**506.18 Shutdown devices and signals**

**506.18.1 Operation.** The operation of fire-extinguishing equipment other than wet chemical and water fire-extinguishing equipment shall automatically shut off all sources of fuel or power to all equipment requiring protection by that fire-extinguishing equipment. Any gas appliance not requiring protection but located under the same exhaust system shall also be shut off. All shutdown devices shall be considered integral parts of the fire-extinguishing equipment and shall function with the operation of the fire-extinguishing equipment. This equipment shall be of the type that requires manual resetting prior to fuel or power restoration. All reset devices shall have ready access.

Wet chemical and water fire-extinguishing equipment shall be provided with an automatic means to ensure the shutdown of fuel or power to the protected appliances and other appliances located under the exhaust system protected by the fire-extinguishing equipment upon the system activation.

**506.18.2 Exhaust Fans.** Exhaust fans shall continue to operate after the fire-extinguishing system has been activated. Supply air fans serving exhaust hood assemblies with integrated supply air plenums shall be shut off when the fire-extinguishing equipment is activated.

## Proposed Rules

**506.18.3 Alarms.** The operation of any fire-extinguishing equipment applicable to this code shall be connected to any type of fire alarm system serving the building, when such alarm system is present. Power to operate the fire-extinguishing equipment shall be monitored by a supervisory alarm.

**506.19 Manual activation of fire-extinguishing equipment**

**506.19.1 Fixed pipe automatic fire-extinguishing equipment** shall be installed to conform with the following requirements:

1. An accessible manual activation device installed at an approved location not more than five (5) feet above the floor shall be provided for wet chemical, dry chemical, carbon dioxide, or other approved equipment. The activation device shall be either mechanical or electrically operated. If electrical power is used, the equipment shall be connected to standby power and a visual means shall be provided to show that the extinguishing equipment is energized.

**EXCEPTION:** An automatic sprinkler or water spray system shall not require manual activation.

2. Instructions for manually operating the fire-extinguishing equipment shall be posted at a location immediately adjacent to the manual activation device within the kitchen.

3. Automatic sprinkler or water spray systems shall be controlled by a separate readily accessible indicating type control valve that is identified.

**506.20 Installation approval of fire-extinguishing equipment**

**506.20.1** The installer of the fire-extinguishing equipment shall document to the owner that the completed system has been installed in accordance with this code and the manufacturer's installation and maintenance manual. This documentation shall include testing in accordance with the manufacturer's installation and maintenance manual. This documentation shall include complete details of the tests performed. This documentation shall include a set of as-built drawings showing the equipment layout and the equipment type. It shall identify the cooking equipment protected and its location under the hood. This documentation shall be permanently maintained on-site. If this documentation is not maintained on-site, then a new test of the system shall be required. The tests performed by the installer shall include operation of mechanical and/or electrical actuation devices. Where distribution piping for fire-extinguishing equipment other than sprinkler or water spray type which cannot be visually inspected shall be air pressure tested to a pressure of not less than twenty (20) psi.

Sprinkler or water spray piping shall be hydrostatically tested where sprinkler or water spray piping is required. After the test, the system shall be charged and placed in the normal operating condition in accordance with the manufacturer's installation and maintenance manual.

**506.21 Maintenance of exhaust hood systems and fire-extinguishing equipment**

**506.21.1.** Maintenance shall be in accordance with the Indiana Fire Prevention Code, 675 IAC 22.

**506.22 Copyright**

**506.22.1.** Portions of this rule are reprinted from NFPA 96-1991, Vapor Removal from Commercial Cooking Equipment, Copyright 1991, National Fire Protection Association, Quincy, Massachusetts 02269. Those portions are found at the following sections of this rule:

506.1

506.3

506.4

506.5

506.8

506.9

506.10

506.11

506.12

506.13

506.16

Asterisks in the text indicate the beginning and ending of each portion of NFPA 96-1991 which is incorporated verbatim. (*Fire Prevention and Building Safety Commission; 675 IAC 18-1.4-22*)

**675 IAC 18-1.4-23 Section 510.1; general**

Authority: IC 22-13-2-2

Affected: IC 22-12; IC 22-13; IC 22-14; IC 22-15; IC 36-7-2-9

**Sec. 23.** Change Section 510.1 General to read as follows: This section shall govern the design and construction of duct systems for hazardous exhaust that are within the scope of Section 101.2 and shall determine where such systems are required. Hazardous exhaust systems are systems designed to capture and control hazardous emissions generated from product handling or processes, and convey those emissions to the outdoors. Hazardous emissions include flammable vapors, gases, fumes, mists or dusts, and volatile or airborne materials posing a health hazard, such as toxic or corrosive materials. For the purposes of this section, the health-hazard rating of materials shall be as specified in NFPA 704. (*Fire Prevention and Building Safety Commission; 675 IAC 18-1.4-23*)

**675 IAC 18-1.4-24 Section 511.1; dust, stock and refuse conveying systems**

Authority: IC 22-13-2-2

Affected: IC 22-12; IC 22-13; IC 22-14; IC 22-15; IC 36-7-2-9

**Sec. 24.** Change Section 511.1 Dust, stock and refuse conveying systems to read as follows: Dust, stock and refuse conveying systems that are within the scope of Section 101.2 shall comply with the provisions of Section 510 and Sections 511.1 through 511.2. (*Fire Prevention and Building Safety Commission; 675 IAC 18-1.4-24*)

**675 IAC 18-1.4-25 Section 512.1; general**

Authority: IC 22-13-2-2  
 Affected: IC 22-12; IC 22-13; IC 22-14; IC 22-15; IC 36-7-2-9

**Sec. 25. Change Section 512.1 General to read as follows: When a subslab soil exhaust system is provided and is within the scope of Section 101.2, the duct shall conform to the requirements of this section. (Fire Prevention and Building Safety Commission; 675 IAC 18-1.4-25)**

**675 IAC 18-1.4-26 Section 513; smoke control systems**

Authority: IC 22-13-2-2  
 Affected: IC 22-12; IC 22-13; IC 22-14; IC 22-15; IC 36-7-2-9

**Sec. 26. Delete Section 513 Smoke control systems and insert the following: See Section 909 of the Indiana Building Code (675 IAC 13). (Fire Prevention and Building Safety Commission; 675 IAC 18-1.4-26)**

**675 IAC 18-1.4-27 Section 603.3; metallic ducts**

Authority: IC 22-13-2-2  
 Affected: IC 22-12; IC 22-13; IC 22-14; IC 22-15; IC 36-7-2-9

**Sec. 27. Change Section 603.3 Metallic ducts to read as follows:**

**603.3 Metallic ducts. All metallic ducts shall be constructed and sealed as specified in the SMACNA HVAC Duct Construction Standards - Metal and Flexible.**

**EXCEPTION: Ducts installed within single dwelling units shall have a minimum thickness as specified in TABLE 603.3.**

**603.3.1 Sealants. Ducts shall be sealed with sealants listed for that purpose, and the sealant shall comply with the flame spread and smoke developed requirement when required by the Indiana Building Code (675 IAC 13) and this code. Ducts shall be sealed in accordance with SMACNA HVAC Duct Construction Standards.**

**603.3.2 Support. All duct suspension and support systems for seismic loads shall comply with the Indiana Building Code (675 IAC 13) and as specified by a registered design professional.**

**TABLE 603.3**

**DUCT CONSTRUCTION MINIMUM SHEET METAL THICKNESSES FOR SINGLE DWELLING UNITS**

DUCT SIZE	GALVANIZED STEEL		APPROXIMATE ALUMINUM B&S GAGE
	Minimum thickness (inches)	Equivalent galvanized Gage No.	
Round ducts and enclosed rectangular ducts			
14" or less	0.013	30	26
Over 14"	0.016	28	24
Exposed rectangular ducts			
14" or less	0.016	28	24
Over 14"	0.019	26	22

For SI: 1 inch = 25.4 mm.

*(Fire Prevention and Building Safety Commission; 675 IAC 18-1.4-27)*

**675 IAC 18-1.4-28 Section 607.2.1; smoke control system**

Authority: IC 22-13-2-2  
 Affected: IC 22-12; IC 22-13; IC 22-14; IC 22-15; IC 36-7-2-9

**Sec. 28. Change Section 607.2.1 Smoke control system as follows: Change "Section 512" to read "Section 909 of the Indiana Building Code (675 IAC 13)". (Fire Prevention and Building Safety Commission; 675 IAC 18-1.4-28)**

**675 IAC 18-1.4-29 Section 607.3.2.1; smoke damper actuation methods**

Authority: IC 22-13-2-2  
 Affected: IC 22-12; IC 22-13; IC 22-14; IC 22-15; IC 36-7-2-9

**Sec. 29. In Section 607.3.2.1 Smoke damper actuation methods, after "Section 907.10", insert "of the Indiana Building Code (675 IAC 13)". (Fire Prevention and Building Safety Commission; 675 IAC 18-1.4-29)**

**675 IAC 18-1.4-30 Section 607.5; where required**

Authority: IC 22-13-2-2  
 Affected: IC 22-12; IC 22-13; IC 22-14; IC 22-15; IC 36-7-2-9

**Sec. 30. Change Section 607.5 Where required to read as follows: Fire dampers, smoke dampers, combination fire/smoke dampers and ceiling radiation dampers shall be provided at the locations prescribed in this section and the Indiana Building Code (675 IAC 13) and as shown on the construction drawings as prepared by the registered design professional. Where an assembly is required to have both fire dampers and smoke dampers, combination fire/smoke dampers or a fire damper and a smoke damper shall be required. (Fire Prevention and Building Safety Commission; 675 IAC 18-1.4-30)**

**675 IAC 18-1.4-31 Section 607.5.1; fire walls**

Authority: IC 22-13-2-2  
 Affected: IC 22-12; IC 22-13; IC 22-14; IC 22-15; IC 36-7-2-9

**Sec. 31. Change Section 607.5.1 Fire walls to read as follows: Ducts and air transfer openings permitted in fire walls in accordance with Section 705.11 of the Indiana Building Code (675 IAC 13) shall be protected with approved fire dampers installed in accordance with their listing. (Fire Prevention and Building Safety Commission; 675 IAC 18-1.4-31)**

**675 IAC 18-1.4-32 Section 607.5.2; fire barriers**

Authority: IC 22-13-2-2  
 Affected: IC 22-12; IC 22-13; IC 22-14; IC 22-15; IC 36-7-2-9

**Sec. 32. Change item 2 in Section 607.5.2 Fire barriers to read as follows: 2. Ducts are used as part of an approved smoke control system in accordance with Section 909 of the Indiana Building Code (675 IAC 13). (Fire Prevention and Building Safety Commission; 675 IAC 18-1.4-32)**

## Proposed Rules

### 675 IAC 18-1.4-33 Table 803.10.6; connector clearances to combustibles

Authority: IC 22-13-2-2

Affected: IC 22-12; IC 22-13; IC 22-14; IC 22-15; IC 36-7-2-9

Sec. 33. In TABLE 803.10.6 CONNECTOR CLEARANCES TO COMBUSTIBLES, change, at the bottom of the MINIMUM CLEARANCE (inches) column, "(As determined by the code official)" to read "(as approved by the code official)". (*Fire Prevention and Building Safety Commission; 675 IAC 18-1.4-33*)

### 675 IAC 18-1.4-34 Section 804; direct-vent, integral vent, mechanical vent and ventilation/exhaust venting

Authority: IC 22-13-2-2

Affected: IC 22-12; IC 22-13; IC 22-14; IC 22-15; IC 36-7-2-9

Sec. 34. Change the title of Section 804 DIRECT-VENT, INTEGRAL VENT, MECHANICAL VENT AND VENTILATION/EXHAUST VENTING to read as follows: DIRECT-VENT, INTEGRAL VENT AND MECHANICAL DRAFT SYSTEMS. (*Fire Prevention and Building Safety Commission; 675 IAC 18-1.4-34*)

### 675 IAC 18-1.4-35 Section 901.1; scope

Authority: IC 22-13-2-2

Affected: IC 22-12; IC 22-13; IC 22-14; IC 22-15; IC 36-7-2-9

Sec. 35. Change the last sentence of Section 901.1 Scope to read as follows: The approval, design, installation, construction and alteration of gas-fired appliances that are within the scope of Section 101.2 shall be regulated by the Indiana Fuel Gas Code (675 IAC 25). (*Fire Prevention and Building Safety Commission; 675 IAC 18-1.4-35*)

### 675 IAC 18-1.4-36 Section 914; sauna heaters

Authority: IC 22-13-2-2

Affected: IC 22-12; IC 22-13; IC 22-14; IC 22-15; IC 36-7-2-9

Sec. 36. Change the title to Section 914 Sauna heaters to read as follows: Sauna heaters within the scope of Section 101.2. (*Fire Prevention and Building Safety Commission; 675 IAC 18-1.4-36*)

### 675 IAC 18-1.4-37 Section 915.1; general

Authority: IC 22-13-2-2

Affected: IC 22-12; IC 22-13; IC 22-14; IC 22-15; IC 36-7-2-9

Sec. 37. Change Section 915.1 General to read as follows: The installation of liquid-fueled stationary internal combustion engines and gas turbines, including storage and piping that are within the scope of Section 101.2, shall meet the requirements of NFPA 37 (675 IAC 13-1-27). (*Fire Prevention and Building Safety Commission; 675 IAC 18-1.4-37*)

### 675 IAC 18-1.4-38 Section 916.1; general

Authority: IC 22-13-2-2

Affected: IC 22-12; IC 22-13; IC 22-14; IC 22-15; IC 36-7-2-9

Sec. 38. Change Section 916.1 General to read as follows: Pool and spa heaters that are within the scope of Section 101.2 shall be installed in accordance with the manufacturer's instructions. Oil-fired pool heaters shall be tested in accordance with UL 726. (*Fire Prevention and Building Safety Commission; 675 IAC 18-1.4-38*)

### 675 IAC 18-1.4-39 Section 917.1; cooking appliances

Authority: IC 22-13-2-2

Affected: IC 22-12; IC 22-13; IC 22-14; IC 22-15; IC 36-7-2-9

Sec. 39. Change the first sentence of Section 917.1 Cooking appliances to read as follows: Cooking appliances that are within the scope of Section 101.2 and that are designed for permanent installation and are part of a Class 1 structure shall be listed, labeled, and installed in accordance with the manufacturer's installation instructions. (*Fire Prevention and Building Safety Commission; 675 IAC 18-1.4-39*)

### 675 IAC 18-1.4-40 Section 923.1; general

Authority: IC 22-13-2-2

Affected: IC 22-12; IC 22-13; IC 22-14; IC 22-15; IC 36-7-2-9

Sec. 40. Change the second line of Section 923.1 General to read as follows: "kilns that are within the scope of Section 101.2 and that are used for ceramics, have a maximum interior vol-...". (*Fire Prevention and Building Safety Commission; 675 IAC 18-1.4-40*)

### 675 IAC 18-1.4-41 Section 924.1; general

Authority: IC 22-13-2-2

Affected: IC 22-12; IC 22-13; IC 22-14; IC 22-15; IC 36-7-2-9

Sec. 41. Change the first line of Section 924.1 General to read as follows: "Stationary fuel cell power plants that are within the scope of Section 101.2 and having a...". (*Fire Prevention and Building Safety Commission; 675 IAC 18-1.4-41*)

### 675 IAC 18-1.4-42 Section 1001.1; scope

Authority: IC 22-13-2-2

Affected: IC 22-12; IC 22-13-2-9; IC 22-14; IC 22-15; IC 36-7-2-9

Sec. 42. Change Section 1001.1 Scope as follows:

(1) Change the first sentence of Section 1001.1 Scope to read as follows: This chapter shall govern the installation and alteration of boilers, water heaters and pressure vessels that are within the scope of Section 101.2.

(2) Add Exception 8 to read as follows: 8. Boilers, water heaters and pressure vessels regulated by the Boiler and Pressure Vessel Board (680 IAC 2) under IC 22-13-2-9 are not regulated by this code.

(*Fire Prevention and Building Safety Commission; 675 IAC 18-1.4-42*)

### 675 IAC 18-1.4-43 Section 1003.3; welding

Authority: IC 22-13-2-2

Affected: IC 22-12; IC 22-13; IC 22-14; IC 22-15; IC 36-7-2-9



**Sec. 43. Change Section 1003.3 Welding by inserting “approved” before “nationally”.** (*Fire Prevention and Building Safety Commission; 675 IAC 18-1.4-43*)

**675 IAC 18-1.4-44 Section 1101.6; general**  
Authority: IC 22-13-2-2  
Affected: IC 22-12; IC 22-13; IC 22-14; IC 22-15; IC 36-7-2-9

**Sec. 44. Change Section 1101.6 General to read as follows: Refrigeration systems within the scope of Section 101.2 shall comply with the requirements of this code and, except as modified by this code, ASHRAE 15. Ammonia-refrigerating systems shall comply with this code and, except as modified by this code, ASHRAE 15.** (*Fire Prevention and Building Safety Commission; 675 IAC 18-1.4-44*)

**675 IAC 18-1.4-45 Section 1102.2.2; purity**  
Authority: IC 22-13-2-2  
Affected: IC 22-12; IC 22-13; IC 22-14; IC 22-15; IC 36-7-2-9

**Sec. 45. Change Section 1102.2.2 Purity to read as follows: Refrigerants used in refrigeration systems shall be new, recovered or reclaimed refrigerants in accordance with Section 1102.2.2.1, Section 1102.2.2.2 or Section 1102.2.2.3. The installer shall furnish to the owner or the owner’s representative, a signed declaration that the refrigerant used meets the requirements of Section 1102.2.2.1, Section 1102.2.2.2 or Section 1102.2.2.3.** (*Fire Prevention and Building Safety Commission; 675 IAC 18-1.4-45*)

**675 IAC 18-1.4-46 Section 1109.1; testing required**  
Authority: IC 22-13-2-2  
Affected: IC 22-12; IC 22-13; IC 22-14; IC 22-15; IC 36-7-2-9

**Sec. 46. Change the third line of Section 1109.1 Testing required to read as follows: “manufacturer’s instructions and local ordinance:...”.** (*Fire Prevention and Building Safety Commission; 675 IAC 18-1.4-46*)

**675 IAC 18-1.4-47 Section 1206.9.1; flood hazard**  
Authority: IC 22-13-2-2  
Affected: IC 22-12; IC 22-13; IC 22-14; IC 22-15; IC 36-7-2-9

**Sec. 47. Delete Section 1206.9.1 Flood hazard and insert “See local Ordinance.”.** (*Fire Prevention and Building Safety Commission; 675 IAC 18-1.4-47*)

**675 IAC 18-1.4-48 Section 1305.2.1; flood hazard**  
Authority: IC 22-13-2-2  
Affected: IC 22-12; IC 22-13; IC 22-14; IC 22-15; IC 36-7-2-9

**Sec. 48. Delete Section 1305.2.1 Flood hazard and insert “See local ordinance.”.** (*Fire Prevention and Building Safety Commission; 675 IAC 18-1.4-48*)

**675 IAC 18-1.4-49 Section 1401.1; scope**  
Authority: IC 22-13-2-2  
Affected: IC 22-12; IC 22-13; IC 22-14; IC 22-15; IC 36-7-2-9

**Sec. 49. Change Section 1401.1 Scope to read as follows: This chapter shall govern the construction, installation and alteration of systems, equipment and appliances intended to utilize solar energy for space heating or cooling, or domestic hot water heating.** (*Fire Prevention and Building Safety Commission; 675 IAC 18-1.4-49*)

**675 IAC 18-1.4-50 Chapter 15; referenced standards**  
Authority: IC 22-13-2-2  
Affected: IC 22-12; IC 22-13; IC 22-14; IC 22-15; IC 36-7-2-9

**Sec. 50. Change in the third sentence of Chapter 15, “Section 102.8” to “Section 101.3”.** (*Fire Prevention and Building Safety Commission; 675 IAC 18-1.4-50*)

SECTION 2. 675 IAC 18-1.3 IS REPEALED.

***Notice of Public Hearing***

*Under IC 4-22-2-24, notice is hereby given that on September 16, 2002 at 10:00 a.m., at the Indiana Government Center-South, 402 West Washington Street, Conference Center Room B, Indianapolis; AND on November 6, 2002 at 10:00 a.m., at the Indiana Government Center-South, 402 West Washington Street, Conference Center Room B, Indianapolis, Indiana the Fire Prevention and Building Safety Commission will hold a public hearing on proposed new rules to adopt and amend the 2000 International mechanical code as the 2003 Indiana mechanical code, 2003 edition. Copies of these rules are now on file at the Indiana Government Center-South, 402 West Washington Street, Room W246 and Legislative Services Agency, One North Capitol, Suite 325, Indianapolis, Indiana and are open for public inspection.*

Patrick Ralston  
Secretary  
Fire Prevention and Building Safety Commission

---

---

**TITLE 675 FIRE PREVENTION AND BUILDING SAFETY COMMISSION**

**Proposed Rule**  
LSA Document #02-117

**DIGEST**

Adds 675 IAC 22-2.3 to adopt and amend the 2000 International Fire Code, fourth printing, as the 2003 Indiana Fire Code. Repeals 675 IAC 22-2.2. Effective 30 days after filing with the secretary of state.

**675 IAC 22-2.2**  
**675 IAC 22-2.3**

SECTION 1. 675 IAC 22-2.3 IS ADDED TO READ AS FOLLOWS:

## Proposed Rules

### Rule 2.3. Indiana Fire Code, 2003 Edition

#### 675 IAC 22-2.3-1 Adoption by reference

Authority: IC 22-13-2-2

Affected: IC 22-12-7; IC 22-13; IC 22-14; IC 36-8-17

Sec. 1. That a certain document being titled the International Fire Code, 2000 Edition, as published by the International Fire Code Institute and the International Code Council, Inc., 5203 Leesburg Pike, Suite 708, Falls Church, Virginia 22041-3401, is hereby adopted by reference as if fully set out in this rule save and except those revisions made in sections 3 through 342 of this rule. (*Fire Prevention and Building Safety Commission; 675 IAC 22-2.3-1*)

#### 675 IAC 22-2.3-2 Section 101.1; title; availability

Authority: IC 22-13-2-2

Affected: IC 22-12-7; IC 22-13; IC 22-14; IC 36-8-17

Sec. 2. Delete Section 101.1 in its entirety and substitute the following: 101.1 Title; Availability.

(a) This rule shall be known as the 2003 Indiana Fire Code, and shall be published, except incorporated documents, by the Department of Fire and Building Services for general distribution and use under that title. Wherever the term "this code" is used throughout this rule, it shall mean the 2003 Indiana Fire Code.

(b) This rule and incorporated documents therein are available to review and as reference at the Department of Fire and Building Services, Indiana Government Center-South, 402 West Washington Street, Room W246, Indianapolis, Indiana 46204. (*Fire Prevention and Building Safety Commission; 675 IAC 22-2.3-2*)

#### 675 IAC 22-2.3-3 Section 101.2; scope

Authority: IC 22-13-2-2

Affected: IC 22-12-7; IC 22-13; IC 22-14; IC 36-8-17

Sec. 3. Delete Section 101.2 and substitute the following: The provisions of this code shall apply to existing conditions as well as to conditions arising after the adoption thereof. Buildings, systems, and uses legally in existence at the adoption of this code shall be permitted to continue so long as they are maintained in a condition that is equivalent to the quality and fire resistive characteristics that existed when the building was constructed, altered, added to, or repaired. (*Fire Prevention and Building Safety Commission; 675 IAC 22-2.3-3*)

#### 675 IAC 22-2.3-4 Section 101.3; intent

Authority: IC 22-13-2-2

Affected: IC 22-12-7; IC 22-13; IC 22-14; IC 36-8-17

Sec. 4. Delete Section 101.3 in its entirety and substitute to read as follows: 101.3 Intent. The intent of this code is to prescribe maintenance, new construction requirements and operational rules for the safeguarding to a reasonable

degree, of life and property from the hazards of fire or explosion arising from the storage, handling, or use of substances, materials, and devices. (*Fire Prevention and Building Safety Commission; 675 IAC 22-2.3-4*)

#### 675 IAC 22-2.3-5 Section 102; application

Authority: IC 22-13-2-2

Affected: IC 22-12-7; IC 22-13; IC 22-14; IC 36-8-17

Sec. 5. Delete Section 102; Application without substitution. (*Fire Prevention and Building Safety Commission; 675 IAC 22-2.3-5*)

#### 675 IAC 22-2.3-6 Section 103; department of fire prevention

Authority: IC 22-13-2-2

Affected: IC 22-12-7; IC 22-13; IC 22-14; IC 36-8-17

Sec. 6. Delete Section 103; Department of Fire Prevention. (*Fire Prevention and Building Safety Commission; 675 IAC 22-2.3-6*)

675 IAC 22-2.3-7 Sections 104.1, 104.2, 104.3, 104.3.1, 104.4, 104.5, 104.6, 104.6.1, 104.6.2, 104.6.3, 104.6.4; general, applications and permits, right of entry, warrant, identification, notices and orders, official records, approvals and variances, inspections, fire records, administrative

Authority: IC 22-13-2-2

Affected: IC 22-12-7; IC 22-13; IC 22-14; IC 36-8-17

Sec. 7. Delete Sections 104.1 through 104.6 without substitution. (*Fire Prevention and Building Safety Commission; 675 IAC 22-2.3-7*)

#### 675 IAC 22-2.3-8 Section 104.7; approved materials and equipment

Authority: IC 22-13-2-2

Affected: IC 22-12-7; IC 22-13; IC 22-14; IC 36-8-17

Sec. 8. Delete the text of Section 104.7 and substitute the following: 104.7 Approval. Wherever in this code the State Fire Marshal, his deputies, or the chief of the fire department or code official are authorized to approve any location, method, material, system, or product in achieving compliance with this code, that decision shall be based on the following:

- (1) Investigation or tests conducted by recognized authorities; or
- (2) Investigation or tests conducted by technical or scientific organizations; or
- (3) Accepted principles.

The investigation, tests or principles shall establish that the materials, equipment and types of construction are safe for their intended purpose. (*Fire Prevention and Building Safety Commission; 675 IAC 22-2.3-8*)

**675 IAC 22-2.3-9 Section 104.7.1; material and equipment reuse**

Authority: IC 22-13-2-2  
Affected: IC 22-12-7; IC 22-13; IC 22-14; IC 36-8-17

**Sec. 9. Delete Section 104.7.1.** (*Fire Prevention and Building Safety Commission; 675 IAC 22-2.3-9*)

**675 IAC 22-2.3-10 Section 104.7.2; technical assistance**

Authority: IC 22-13-2-2  
Affected: IC 22-12-7; IC 22-13; IC 22-14; IC 36-8-17

**Sec. 10. In Section 104.7.2, delete the last sentence.** (*Fire Prevention and Building Safety Commission; 675 IAC 22-2.3-10*)

**675 IAC 22-2.3-11 Sections 104.8, 104.9, 104.10; modifications, alternative materials and methods, fore investigations**

Authority: IC 22-13-2-2  
Affected: IC 22-12-7; IC 22-13; IC 22-14; IC 36-8-17

**Sec. 11. Delete Sections 104.8 through 104.10 without substitution.** (*Fire Prevention and Building Safety Commission; 675 IAC 22-2.3-11*)

**675 IAC 22-2.3-12 Section 105; permits**

Authority: IC 22-13-2-2  
Affected: IC 22-12-7; IC 22-13; IC 22-14; IC 36-8-17

**Sec. 12. Delete Section 105 without substitution.** (*Fire Prevention and Building Safety Commission; 675 IAC 22-2.3-12*)

**675 IAC 22-2.3-13 Section 106; inspections**

Authority: IC 22-13-2-2  
Affected: IC 22-12-7; IC 22-13; IC 22-14; IC 36-8-17

**Sec. 13. Delete Section 106 without substitution.** (*Fire Prevention and Building Safety Commission; 675 IAC 22-2.3-13*)

**675 IAC 22-2.3-14 Section 107.1; maintenance of safeguards**

Authority: IC 22-13-2-2  
Affected: IC 22-12-7; IC 22-13; IC 22-14; IC 36-8-17

**Sec. 14. Delete Section 107.1 without substitution.** (*Fire Prevention and Building Safety Commission; 675 IAC 22-2.3-14*)

**675 IAC 22-2.3-15 Section 107.2; test and inspection records**

Authority: IC 22-13-2-2  
Affected: IC 22-12-7; IC 22-13; IC 22-14; IC 36-8-17

**Sec. 15. Amend Section 107.2.1 Test and Inspection Records to read as follows: Written records of maintenance, test, and inspections shall be maintained on the premises where the equipment is located, or at a corporate central office and shall be made immediately available to the inspection authority on request.** (*Fire Prevention and Building Safety Commission; 675 IAC 22-2.3-15*)

**675 IAC 22-2.3-16 Sections 108, 109, 110, 111; board of appeals, violations, unsafe buildings, stop work order**

Authority: IC 22-13-2-2  
Affected: IC 22-12-7; IC 22-13; IC 22-14; IC 36-8-17

**Sec. 16. Delete Sections 108 through 111 without substitution.** (*Fire Prevention and Building Safety Commission; 675 IAC 22-2.3-16*)

**675 IAC 22-2.3-17 Section 201.3; terms defined in other codes**

Authority: IC 22-13-2-2  
Affected: IC 22-12-7; IC 22-13; IC 22-14; IC 36-8-17

**Sec. 17. Delete the text of Section 201.3 Terms defined in other codes and substitute to read as follows: Where terms are not defined in this code and are defined in the Indiana Building Code, Indiana Electrical Code, Indiana Fuel Gas Code, Indiana Mechanical Code, or Indiana Plumbing Code, such terms shall have the meanings ascribed to them as in those codes.** (*Fire Prevention and Building Safety Commission; 675 IAC 22-2.3-17*)

**675 IAC 22-2.3-18 Section 201.3.1; terms defined in other codes**

Authority: IC 22-13-2-2  
Affected: IC 22-12-7; IC 22-13; IC 22-14; IC 36-8-17

**Sec. 18. Add Section 201.3.1 to read as follows: 201.3.1. Terms defined in other codes. Where the terms in International Building Code, International Mechanical Code, International Fuel Gass Code, or International Plumbing Code appear in this code, change "International" to "Indiana". Where the ICC Electrical Code is used, it shall mean Indiana Electrical Code.** (*Fire Prevention and Building Safety Commission; 675 IAC 22-2.3-18*)

**675 IAC 22-2.3-19 Section 202; general definitions**

Authority: IC 22-13-2-2  
Affected: IC 22-12-7; IC 22-13; IC 22-14; IC 25-24; IC 25-31; IC 36-8-17

**Sec. 19. In Section 202, change the following definitions to read:**

**APPROVED.** As to materials, equipment, design, and types of construction, acceptance by the code official by one of the following methods:

- (1) Investigation or tests conducted by recognized authorities; or
- (2) Investigation or tests conducted by technical or scientific organizations; or
- (3) Accepted principles.

The investigation, tests or principal shall established that the materials, equipment and types of construction are safe for the intended purpose.

**AUTOMOTIVE SERVICE STATION. MOTOR FUEL DISPENSING FACILITY.** See Section 2202.1.

## Proposed Rules

**CODE OFFICIAL.** The office of the state building commissioner authorized under IC 22-15-2-7; the office of the state fire marshal authorized under IC 22-14-2-10; the local building official authorized under IC 36-7-9 and local ordinance; the fire department authorized under IC 36-8-17-9 or local ordinance.

**FACILITY.** A building or use in a fixed location, including exterior storage areas for flammable and combustible substances and hazardous materials, piers, wharves, tank farms and similar uses.

**HIGH VOLATILE LIQUID.** A liquefied compressed gas with a boiling point of less than 65°F (20°C).

**OCCUPANCY CLASSIFICATION.** Occupancy classification shall be as specified in the Building Code in effect at the time of construction, alteration, or change of occupancy.

**REGISTERED DESIGN PROFESSIONAL.** A registered architect or professional engineer registered under IC 25-4 or IC 25-31. If a registered design professional is not required by 675 IAC 12-6 or 675 IAC 15, then it means the owner.

*(Fire Prevention and Building Safety Commission; 675 IAC 22-2.3-19)*

### 675 IAC 22-2.3-20 Section 202; general definitions

Authority: IC 22-13-2-2

Affected: IC 22-12-7; IC 22-13; IC 22-14; IC 36-8-17

Sec. 20. In Section 202, delete the following definitions: **CONSTRUCTION DOCUMENTS**, **FIRE ALARM SPECIAL AMUSEMENT BUILDING**, and **TIRES, BULK STORAGE OF**. *(Fire Prevention and Building Safety Commission; 675 IAC 22-2.3-20)*

### 675 IAC 22-2.3-21 Section 202; general definitions

Authority: IC 22-13-2-2

Affected: IC 22-12-7; IC 22-13; IC 22-14; IC 36-8-17

Sec. 21. In Section 202, add the following definitions: **BUILDING CODE.** The building code in effect in Indiana at the time of construction, remodeling, alteration, addition, or repair of a structure.

**CHIEF:** See **CODE OFFICIAL**.

**COMMISSION** is the Indiana Fire Prevention and Building Safety Commission as set forth at IC 22-12-2-1. **COMPATIBLE** is approved equipment which functions effectively with other approved equipment within an alarm system.

**CONTROL UNIT** is a combination of equipment which contains the primary and secondary power supplies, receives signals from initiating devices, transmits signals to signaling devices, and electrically supervises the system circuitry.

**ELECTRICAL CODE** is the electrical code in effect in Indiana at the time of construction, remodeling, alteration, addition, or repair of a structure.

**FIRE ALARM SIGNAL.** An audible or visual signal, indicating the existence of an emergency requiring immediate action

**FIRE ALARM SYSTEM.** A Combination of approved equipment which with operation of an alarm initiating device produces an alarm signal.

**FLAME RESISTANT MATERIAL** is material that has been modified in its chemical composition by impregnation, coating or has inherent composition that makes the material resistant to ignition and combustion when exposed to a small ignition source.

**FLAME RETARDANT.** An approved chemical, chemical compound or mixture which, when applied in an approved manner to any fabric or other material, will render such fabric or material incapable of supporting combustion.

**INSPECTION AUTHORITY.** See **CODE OFFICIAL**.

**MARINE SERVICE STATION. MARINE MOTOR FUEL DISPENSING FACILITY.** See Section 2202.1.

**MECHANICAL CODE.** The mechanical code in effect in Indiana at the time of construction, remodeling, alteration, addition, or repair of a structure.

**PLUMBING CODE.** The plumbing code in effect in Indiana at the time of construction, remodeling, alteration, addition, or repair of a structure.

**QUALIFIED INDIVIDUAL** is a person who has successfully completed instruction related to the equipment being installed, serviced, or repaired.

**SERVICING FIRE DEPARTMENT:** See **CODE OFFICIAL**.

**TRAINED PERSONNEL (Individual):** See **QUALIFIED PERSONNEL (Individual)**.

*(Fire Prevention and Building Safety Commission; 675 IAC 22-2.3-21)*

### 675 IAC 22-2.3-22 Section 301.2; permits

Authority: IC 22-13-2-2

Affected: IC 22-12-7; IC 22-13; IC 22-14; IC 36-8-17

Sec. 22. Delete Section 301.2 Permits without substitution. *(Fire Prevention and Building Safety Commission; 675 IAC 22-2.3-22)*

### 675 IAC 22-2.3-23 Section 304.2; storage

Authority: IC 22-13-2-2

Affected: IC 22-12-7; IC 22-13; IC 22-14; IC 36-8-17

Sec. 23. Amend Section 304.2 Storage to read as follows: **Storage of combustible rubbish shall not produce conditions that will create a fire hazard that endangers the safety of persons or property.** *(Fire Prevention and Building Safety Commission; 675 IAC 22-2.3-23)*

### 675 IAC 22-2.3-24 Section 307.2; permits

Authority: IC 22-13-2-2

Affected: IC 22-12-7; IC 22-13; IC 22-14; IC 36-8-17

**Sec. 24. Amend Section 307.2 to read as follows: Notification.** Prior to commencement of open burning, the fire department having jurisdiction shall be notified. *(Fire Prevention and Building Safety Commission; 675 IAC 22-2.3-24)*

**675 IAC 22-2.3-25 Section 307.2.2; prohibited open burning**

Authority: IC 22-13-2-2  
Affected: IC 22-12-7; IC 22-13; IC 22-14; IC 36-8-17

**Sec. 25. Amend Section 307.2.2 to read as follows: Discontinuance.** The chief is authorized to require open burning be immediately discontinued if such fires constitute a hazardous condition. *(Fire Prevention and Building Safety Commission; 675 IAC 22-2.3-25)*

**675 IAC 22-2.3-26 Section 307.2.3; material restrictions**

Authority: IC 22-13-2-2  
Affected: IC 22-12-7; IC 22-13; IC 22-14; IC 36-8-17

**Sec. 26. Add Section 307.2.3 to read as follows: 307.2.3 Material restrictions.** Open burning of rubbish containing paper products is prohibited. *(Fire Prevention and Building Safety Commission; 675 IAC 22-2.3-26)*

**675 IAC 22-2.3-27 Section 307.4; attendance**

Authority: IC 22-13-2-2  
Affected: IC 22-12-7; IC 22-13; IC 22-14; IC 36-8-17

**Sec. 27. Amend Section 307.4 to read as follows: Burning material shall be constantly attended by a person knowledgeable in the use of the fire-extinguishing equipment required by this section and familiar with any limitations which restrict open burning.** An attendant shall supervise the burning material until the fire has been extinguished. *(Fire Prevention and Building Safety Commission; 675 IAC 22-2.3-27)*

**675 IAC 22-2.3-28 Section 308.3; open flame**

Authority: IC 22-13-2-2  
Affected: IC 22-12-7; IC 22-13; IC 22-14; IC 36-8-17

**Sec. 28. Amend Section 308.3 by deleting “obtaining a permit in accordance with Section 105.6” and substituting “notifying the fire department having jurisdiction”.** *(Fire Prevention and Building Safety Commission; 675 IAC 22-2.3-28)*

**675 IAC 22-2.3-29 Section 308.3.4; religious ceremonies**

Authority: IC 22-13-2-2  
Affected: IC 22-12-7; IC 22-13; IC 22-14; IC 36-8-17

**Sec. 29. In section 308.3.4, delete “in the opinion of the code official, adequate” and substitute “approved”.** *(Fire Prevention and Building Safety Commission; 675 IAC 22-2.3-29)*

**675 IAC 22-2.3-30 Section 308.4.1; approval**

Authority: IC 22-13-2-2  
Affected: IC 22-12-7; IC 22-13; IC 22-14; IC 36-8-17

**Sec. 30. Amend Section 308.4.1 to read as follows: Prior to using a torch or flame-producing device to remove paint from a structure, the fire department having jurisdiction shall be notified.** *(Fire Prevention and Building Safety Commission; 675 IAC 22-2.3-30)*

**675 IAC 22-2.3-31 Section 308.5; open-flame devices**

Authority: IC 22-13-2-2  
Affected: IC 22-12-7; IC 22-13; IC 22-14; IC 36-8-17

**Sec. 31. Amend Section 308.5 to read as follows: In the first sentence, delete all text after “hazardous fire areas, except” and substitute “when approved”.** *(Fire Prevention and Building Safety Commission; 675 IAC 22-2.3-31)*

**675 IAC 22-2.3-32 Section 310.2; prohibited areas**

Authority: IC 22-13-2-2  
Affected: IC 22-12-7; IC 22-13; IC 22-14; IC 36-8-17

**Sec. 32. Amend Section 310.2 to read as follows: Whenever smoking constitutes a fire hazard in any area of piers, wharfs, warehouses, stores, industrial plants, institutions, schools, places of assembly, and in open spaces where combustible materials are stored or handled, the chief is authorized to order the owner or occupant to post approved NO SMOKING signs in each building, structure, room, or place in which smoking is prohibited. Such signs shall be conspicuously and suitably located and shall be maintained.**

**EXCEPTIONS: 1. Buildings or structures which are smoke-free environments and are posted as such at all public and employee entrances.**

**2. No visible evidence of prohibited smoking exists within the building or structure.**

*(Fire Prevention and Building Safety Commission; 675 IAC 22-2.3-32)*

**675 IAC 22-2.3-33 Section 311.2.2; fire protection**

Authority: IC 22-13-2-2  
Affected: IC 22-12-7; IC 22-13; IC 22-14; IC 36-8-17

**Sec. 33. Amend Section 311.2.2 by deleting exceptions 1 and 2.** *(Fire Prevention and Building Safety Commission; 675 IAC 22-2.3-33)*

**675 IAC 22-2.3-34 Section 313.1; vehicle storage**

Authority: IC 22-13-2-2  
Affected: IC 22-12-7; IC 22-13; IC 22-14; IC 36-8-17

**Sec. 34. Amend Section 313.1, Exception 1 by deleting “See Section 8-4 of NFPA 58” and substituting “Section 15 of this code”.** *(Fire Prevention and Building Safety Commission; 675 IAC 22-2.3-34)*

**675 IAC 22-2.3-35 Section 315.1; general**

Authority: IC 22-13-2-2  
Affected: IC 22-12-7; IC 22-13; IC 22-14; IC 36-8-17

**Sec. 35. Amend Section 315.1 by deleting the last sen-**

## Proposed Rules

tence. (*Fire Prevention and Building Safety Commission; 675 IAC 22-2.3-35*)

### 675 IAC 22-2.3-36 Section 316; outdoor carnivals and fairs

Authority: IC 22-13-2-2

Affected: IC 22-12-7; IC 22-13; IC 22-14; IC 36-8-17

Sec. 36. Add Section 316 Outdoor Carnivals and Fairs to read as follows:

#### SECTION 316. CARNIVALS AND FAIRS

316.1 General. The grounds of carnivals and fairs, including concession booths, shall be in accordance with Section 316.

#### 316.2 Grounds.

316.2.1 General. Grounds shall be in accordance with Section 316.2.

316.2.2 Access. Fire apparatus access roads shall be provided in accordance with Section 503.

#### 316.2.3 Fire appliances.

316.2.3.1 General. Fire appliances shall be provided for the entire midway, as required by the chief.

316.2.3.2 Location. Maximum travel distance to a portable fire extinguisher shall not exceed seventy-five (75) feet (22,860 mm).

316.2.4 Electrical equipment. Electrical equipment and installations shall comply with the Electrical Code (675 IAC 17).

#### 316.3 Concession Stands.

316.3.1 General. Concession stands shall be in accordance with Section 316.3.

316.3.2 Location. Concession stands utilized for cooking shall have a minimum of ten (10) feet (3,048 mm) of clearance on two (2) sides and shall not be located within ten (10) feet (3,048 mm) of amusement rides or devices.

316.3.3 Fire extinguishers. A 40-B:C-rated dry chemical fire extinguisher shall be provided where deep-fat fryers are used.

#### 316.4 Internal Combustion Power Sources.

316.4.1 General. Internal combustion power sources, including motor vehicles, generators and similar equipment, shall be in accordance with Section 316.4.

316.4.2 Fueling. Fuel tanks shall be of adequate capacity to permit uninterrupted operation during normal operating hours. Refueling shall be conducted only when the ride is not in use.

316.4.3 Protection. Internal combustion power sources shall be isolated from contact with the public by either physical guards, fencing or an enclosure.

316.4.4 Fire extinguishers. A minimum of one (1) fire extinguisher with a rating of not less than 2-A:10-B:C shall be provided. (*Fire Prevention and Building Safety Commission; 675 IAC 22-2.3-36*)

### 675 IAC 22-2.3-37 Section 408.7.3; notification

Authority: IC 22-13-2-2

Affected: IC 22-12-7; IC 22-13; IC 22-14; IC 36-8-17

Sec. 37. Change Section 408.7.3 to read as follows: Provisions shall be made for residents in Use Conditions 3, 4, and 5 as defined in the Indiana Building Code Section 308.4 to immediately notify staff of an emergency. (*Fire Prevention and Building Safety Commission; 675 IAC 22-2.3-37*)

### 675 IAC 22-2.3-38 Section 501.2; permits

Authority: IC 22-13-2-2

Affected: IC 22-12-7; IC 22-13; IC 22-14; IC 36-8-17

Sec. 38. Delete Section 501.2 without substitution. (*Fire Prevention and Building Safety Commission; 675 IAC 22-2.3-38*)

### 675 IAC 22-2.3-39 Section 501.3; construction documents

Authority: IC 22-13-2-2

Affected: IC 22-12-7; IC 22-13; IC 22-14; IC 36-8-17

Sec. 39. In Section 501.3, delete "and approval" without substitution. (*Fire Prevention and Building Safety Commission; 675 IAC 22-2.3-39*)

### 675 IAC 22-2.3-40 Section 503.1.1; buildings and facilities

Authority: IC 22-13-2-2

Affected: IC 22-12-7; IC 22-13; IC 22-14; IC 36-8-17

Sec. 40. Change Section 503.1.1 as follows: Delete the EXCEPTION and substitute the following: EXCEPTION: Buildings protected throughout by a supervised automatic fire sprinkler system and not used for high-piled combustible storage in excess of twelve thousand (12,000) square feet. (*Fire Prevention and Building Safety Commission; 675 IAC 22-2.3-40*)

### 675 IAC 22-2.3-41 Section 503.1.2; additional access

Authority: IC 22-13-2-2

Affected: IC 22-12-7; IC 22-13; IC 22-14; IC 36-8-17

Sec. 41. Delete Section 503.1.2. (*Fire Prevention and Building Safety Commission; 675 IAC 22-2.3-41*)

### 675 IAC 22-2.3-42 Section 503.1.4; lumber storage

Authority: IC 22-13-2-2

Affected: IC 22-12-7; IC 22-13; IC 22-14; IC 36-8-17

Sec. 42. Add Section 503.1.4 to read as follows: For exterior lumber storage, see Section 1903.6. (*Fire Prevention and Building Safety Commission; 675 IAC 22-2.3-42*)

### 675 IAC 22-2.3-43 Section 503.2.2; authority

Authority: IC 22-13-2-2

Affected: IC 22-12-7; IC 22-13; IC 22-14; IC 36-8-17

Sec. 43. Change Section 503.2.2 to read as follows: Vertical clearances or widths required by this section shall be increased when vertical clearances or widths do not provide fire apparatus access for the largest vehicle ex-

pected to be used by the servicing fire department. (*Fire Prevention and Building Safety Commission; 675 IAC 22-2.3-43*)

**675 IAC 22-2.3-44 Section 503.2.3; surface**

Authority: IC 22-13-2-2

Affected: IC 22-12-7; IC 22-13; IC 22-14; IC 36-8-17

Sec. 44. Change Section 503.2.3 to read as follows: Fire apparatus access roads shall be designed and constructed to support the imposed live loads of the heaviest piece of fire department apparatus available to the servicing fire department and shall be provided with a surface so as to provide all-weather driving capabilities. (*Fire Prevention and Building Safety Commission; 675 IAC 22-2.3-44*)

**675 IAC 22-2.3-45 Section 503.2.4; turning radius**

Authority: IC 22-13-2-2

Affected: IC 22-12-7; IC 22-13; IC 22-14; IC 36-8-17

Sec. 45. Change Section 503.2.4 to read as follows: The turning radius of a fire apparatus access road shall be determined after consultation with the servicing fire department and shall be at least equal to the minimum required radius for the fire apparatus. Such roads shall be designed and constructed to permit turning of the longest piece of fire apparatus available to the servicing fire department. (*Fire Prevention and Building Safety Commission; 675 IAC 22-2.3-45*)

**675 IAC 22-2.3-46 Section 503.2.5; dead ends**

Authority: IC 22-13-2-2

Affected: IC 22-12-7; IC 22-13; IC 22-14; IC 36-8-17

Sec. 46. Change Section 503.2.5 to read as follows: Dead-end fire apparatus access roads in excess of one hundred fifty (150) feet in length shall be designed and constructed so as to allow the turning around of the longest piece of fire apparatus available to the servicing fire department. (*Fire Prevention and Building Safety Commission; 675 IAC 22-2.3-46*)

**675 IAC 22-2.3-47 Section 503.2.6; bridges and elevated surfaces**

Authority: IC 22-13-2-2

Affected: IC 22-12-7; IC 22-13; IC 22-14; IC 36-8-17

Sec. 47. Amend Section 503.2.6 to read as follows:

(1) In the third sentence, delete “when required by the code official”.

(2) Amend the last sentence to read as follows: Where elevated surfaces designed for emergency vehicle use are adjacent to surfaces which are not designed for such use, approved barriers or approved signs shall be installed.

(*Fire Prevention and Building Safety Commission; 675 IAC 22-2.3-47*)

**675 IAC 22-2.3-48 Section 503.2.7; grade**

Authority: IC 22-13-2-2

Affected: IC 22-12-7; IC 22-13; IC 22-14; IC 36-8-17

Sec. 48. Change Section 503.2.7 to read as follows: The gradient for all fire apparatus access roads shall not exceed the maximum that the apparatus available to the servicing fire department can accommodate. (*Fire Prevention and Building Safety Commission; 675 IAC 22-2.3-48*)

**675 IAC 22-2.3-49 Section 503.3; marking**

Authority: IC 22-13-2-2

Affected: IC 22-12-7; IC 22-13; IC 22-14; IC 36-8-17

Sec. 49. Change Section 503.3 to read as follows: When required by local ordinance, signs, or other notices shall be provided and maintained for the fire apparatus access roads to identify such roads and prohibit the obstruction thereof. (*Fire Prevention and Building Safety Commission; 675 IAC 22-2.3-49*)

**675 IAC 22-2.3-50 Section 503.5; required gates or barricades**

Authority: IC 22-13-2-2

Affected: IC 22-12-7; IC 22-13; IC 22-14; IC 36-8-17

Sec. 50. Amend Section 503.5 by adding to the beginning “When required by local ordinance”. (*Fire Prevention and Building Safety Commission; 675 IAC 22-2.3-50*)

**675 IAC 22-2.3-51 Section 504.1; required access**

Authority: IC 22-13-2-2

Affected: IC 22-12-7; IC 22-13; IC 22-14; IC 36-8-17

Sec. 51. In Section 504.1, delete the last sentence. (*Fire Prevention and Building Safety Commission; 675 IAC 22-2.3-51*)

**675 IAC 22-2.3-52 Section 504.2; maintenance of exterior doors and openings**

Authority: IC 22-13-2-2

Affected: IC 22-12-7; IC 22-13; IC 22-14; IC 36-8-17

Sec. 52. In Section 504.2, change the first sentence to read as follows: Exterior doors and their function shall be maintained in accordance with 675 IAC 12-4-9. (*Fire Prevention and Building Safety Commission; 675 IAC 22-2.3-52*)

**675 IAC 22-2.3-53 Section 506; key boxes**

Authority: IC 22-13-2-2

Affected: IC 22-12-7; IC 22-13; IC 22-14; IC 36-8-17

Sec. 53. Delete the text of Section 506 and substitute to read as follows: When Required. Whenever the servicing fire department has instituted a key box emergency access system, a key box compatible with that system shall be installed in an accessible location if:

(1) the building is protected with an automatic sprinkler system equipped with a local or transmitted water-flow alarm, or

(2) the building is provided with any fire alarm system equipped with an outside audible/visual signaling device, or

(3) the building is provided with any fire alarm system

## Proposed Rules

where the alarm is transmitted to an off-site location, or to the fire alarm center for the servicing fire department.

**506.2 Responsibility for Key Box.** Key boxes are to be provided by the building owner and shall contain such keys necessary to access all protected areas of the building. Multi-tenant buildings may share an owner-provided box, and the building owner shall assume responsibility for insuring that keys are updated as appropriate. Tenant-provided boxes may not be shared with any other tenant, and the tenant assumes responsibility for key updates for the subject tenant space.

**EXCEPTION:** Key boxes for apartment houses are not required to contain keys to individual apartment dwelling units.

**506.3 Existing Buildings.** When a design release is issued by the office of the state building commissioner or a permit by local government when a design release is not required for construction, buildings prior to the effective date of this code shall not be required to provide a key box or key boxes under this section. Any new tenancy within a space previously occupied by a different tenant shall require that a key box be provided in accordance with Sections 902.4 and 902.4.1. Existing buildings required to install a key box or key boxes by this section shall not be in violation of this section until one (1) year after the effective date of this code. *(Fire Prevention and Building Safety Commission; 675 IAC 22-2.3-53)*

**675 IAC 22-2.3-54 Section 507.2.1; exterior access to shaftways**

Authority: IC 22-13-2-2  
Affected: IC 22-12-7; IC 22-13; IC 22-14; IC 36-8-17

**Sec. 54.** In Section 507.2.1, delete “from the outside of the building”. *(Fire Prevention and Building Safety Commission; 675 IAC 22-2.3-54)*

**675 IAC 22-2.3-55 Section 508.1, Section 508.2; required water supply, type of water supply**

Authority: IC 22-13-2-2  
Affected: IC 22-12-7; IC 22-13; IC 22-14; IC 36-8-17

**Sec. 55.** Delete Sections 508.1 and 508.2 and substitute the following: **Required Water Supply for Fire Protection.** A water supply capable of supplying the required fire flow, for firefighting purposes, as determined by local ordinance, shall be provided to all premises upon which a Class 1 building or a portion of Class 1 buildings are hereafter constructed. The water supply shall be provided as follows:

- (1) When a public water supply is available to a premises, there shall be provided fire hydrants and mains capable of supplying the required fire flow.
- (2) When a public water supply is not available to a premises, the water supply shall consist of a pond,

stream, river, canal, lake, reservoir, quarry, pressure tank, elevated tank, swimming pool, other fixed systems, or fire department delivered portable system capable of providing the required fire flow. The on-site water supply shall be accessible to the fire department and be located within one hundred fifty (150) feet of the Class 1 building or structure being protected with an automatic fire-extinguishing system. If the on-site water supply is not within one hundred fifty (150) feet of the structure being protected, the water supply shall be connected to on-site fire hydrants and mains capable of supplying the required fire flow. The owner shall verify the water supply requirements with the servicing fire department prior to final design and construction.

(3) Private fire service mains and appurtenances shall be installed in accordance with NFPA 24.

(4) Water tanks for private fire protection shall be installed in accordance with NFPA 22.

*(Fire Prevention and Building Safety Commission; 675 IAC 22-2.3-55)*

**675 IAC 22-2.3-56 Section 508.3; fire flow**

Authority: IC 22-13-2-2  
Affected: IC 22-12-7; IC 22-13; IC 22-14; IC 36-8-17

**Sec. 56.** Change Section 508.3 to read as follows: **In setting the requirements for the fire flow, the chief may be guided by Appendix B, when required by local ordinance.** *(Fire Prevention and Building Safety Commission; 675 IAC 22-2.3-56)*

**675 IAC 22-2.3-57 Section 508.5.1; where required**

Authority: IC 22-13-2-2  
Affected: IC 22-12-7; IC 22-13; IC 22-14; IC 36-8-17

**Sec. 57.** In Section 508.5.1, delete “where required by the code official”. *(Fire Prevention and Building Safety Commission; 675 IAC 22-2.3-57)*

**675 IAC 22-2.3-58 Section 508.5.2; inspection, testing and maintenance**

Authority: IC 22-13-2-2  
Affected: IC 22-12-7; IC 22-13; IC 22-14; IC 36-8-17

**Sec. 58.** In Section 508.5.2, delete the first sentence. *(Fire Prevention and Building Safety Commission; 675 IAC 22-2.3-58)*

**675 IAC 22-2.3-59 Section 509.1; features**

Authority: IC 22-13-2-2  
Affected: IC 22-12-7; IC 22-13; IC 22-14; IC 36-8-17

**Sec. 59.** In Section 509.1, change the fifth sentence to read as follows: **A layout of the fire command center and all features required by this section shall be submitted to the fire department having jurisdiction prior to installation.** *(Fire Prevention and Building Safety Commission; 675 IAC 22-2.3-59)*



**675 IAC 22-2.3-60 Section 601.2; permits**  
 Authority: IC 22-13-2-2  
 Affected: IC 22-12-7; IC 22-13; IC 22-14; IC 36-8-17

**Sec. 60. Delete Section 601.2 without substitution.** (*Fire Prevention and Building Safety Commission; 675 IAC 22-2.3-60*)

**675 IAC 22-2.3-61 Section 603.3.1; maximum outside fuel oil storage above ground**  
 Authority: IC 22-13-2-2  
 Affected: IC 22-12-7; IC 22-13; IC 22-14; IC 36-8-17

**Sec. 61. In Section 603.3.1, delete “NFPA 31” and insert “Chapter 34 of this code”.** (*Fire Prevention and Building Safety Commission; 675 IAC 22-2.3-61*)

**675 IAC 22-2.3-62 Section 603.3.3; underground storage of fuel oil**  
 Authority: IC 22-13-2-2  
 Affected: IC 22-12-7; IC 22-13; IC 22-14; IC 36-8-17

**Sec. 62. In Section 603.3.3, delete “NFPA 31” and insert “Chapter 34 of this code”.** (*Fire Prevention and Building Safety Commission; 675 IAC 22-2.3-62*)

**675 IAC 22-2.3-63 Section 603.4; portable unvented heaters**  
 Authority: IC 22-13-2-2  
 Affected: IC 22-12-7; IC 22-13; IC 22-14; IC 36-8-17

**Sec. 63. Change Section 603.4 to read as follows: 603.4 Portable unvented heaters. The use of listed portable unvented oil-burning heating appliances shall be limited to supplemental heating in detached single family residences. EXCEPTION: Upon approval of the code official, portable unvented oil-burning heating appliances may be permitted in any occupancy during the construction process when such is necessary for the construction and the use does not represent a hazard of life or property.** (*Fire Prevention and Building Safety Commission; 675 IAC 22-2.3-63*)

**675 IAC 22-2.3-64 Section 603.8.5; discontinuance**  
 Authority: IC 22-13-2-2  
 Affected: IC 22-12-7; IC 22-13; IC 22-14; IC 36-8-17

**Sec. 64. Delete the text of Section 603.8.5 and substitute to read as follows: The chief is authorized to require incinerator use to be immediately discontinued if the use of the incinerator constitutes a hazardous condition.** (*Fire Prevention and Building Safety Commission; 675 IAC 22-2.3-64*)

**675 IAC 22-2.3-65 Section 604.1; installation**  
 Authority: IC 22-13-2-2  
 Affected: IC 22-12-7; IC 22-13; IC 22-14; IC 36-8-17

**Sec. 65. In Section 604.1, delete “NFPA 110 and NFPA 111”.** (*Fire Prevention and Building Safety Commission; 675 IAC 22-2.3-65*)

**675 IAC 22-2.3-66 Section 604.1.1; stationary generators**  
 Authority: IC 22-13-2-2  
 Affected: IC 22-12-7; IC 22-13; IC 22-14; IC 36-8-17

**Sec. 66. In Section 604.1.1, delete “comply” and insert “be listed in accordance with”.** (*Fire Prevention and Building Safety Commission; 675 IAC 22-2.3-66*)

**675 IAC 22-2.3-67 Section 605.3; working space and clearance**  
 Authority: IC 22-13-2-2  
 Affected: IC 22-12-7; IC 22-13; IC 22-14; IC 36-8-17

**Sec. 67. In Section 605.3, delete EXCEPTION 2.** (*Fire Prevention and Building Safety Commission; 675 IAC 22-2.3-67*)

**675 IAC 22-2.3-68 Section 605.5.1; power supply**  
 Authority: IC 22-13-2-2  
 Affected: IC 22-12-7; IC 22-13; IC 22-14; IC 36-8-17

**Sec. 68. In Section 605.5.1, delete “power tap or multiplug adapter and”.** (*Fire Prevention and Building Safety Commission; 675 IAC 22-2.3-68*)

**675 IAC 22-2.3-69 Section 606.5; access**  
 Authority: IC 22-13-2-2  
 Affected: IC 22-12-7; IC 22-13; IC 22-14; IC 36-8-17

**Sec. 69. In Section 606.5, delete “as required by the code official”.** (*Fire Prevention and Building Safety Commission; 675 IAC 22-2.3-69*)

**675 IAC 22-2.3-70 Section 606.6.1; periodic testing**  
 Authority: IC 22-13-2-2  
 Affected: IC 22-12-7; IC 22-13; IC 22-14; IC 36-8-17

**Sec. 70. In Section 606.6.1, delete “and as required by the code official”.** (*Fire Prevention and Building Safety Commission; 675 IAC 22-2.3-70*)

**675 IAC 22-2.3-71 Section 606.11.3; ammonia refrigerants**  
 Authority: IC 22-13-2-2  
 Affected: IC 22-12-7; IC 22-13; IC 22-14; IC 36-8-17

**Sec. 71. Amend Section 606.11.3 by adding Exception 2 to read as follows: 2. When the code official determines, upon review of an engineering analysis prepared in accordance with Section 104.7.2, that a fire or explosion hazard would not result from discharging ammonia directly to atmosphere.** (*Fire Prevention and Building Safety Commission; 675 IAC 22-2.3-71*)

**675 IAC 22-2.3-72 Section 606.13; notification of discharges**  
 Authority: IC 22-13-2-2  
 Affected: IC 22-12-7; IC 22-13; IC 22-14; IC 36-8-17

**Sec. 72. Amend Section 606.13 Notification of discharges**

## Proposed Rules

to read as follows: **606.13 Notification of refrigerant discharges.** The code official shall be notified immediately when a discharge becomes reportable under Section 2703.3.1. (*Fire Prevention and Building Safety Commission; 675 IAC 22-2.3-72*)

### **675 IAC 22-2.3-73 Section 607; elevator recall and maintenance**

Authority: IC 22-13-2-2  
Affected: IC 22-12-7; IC 22-13; IC 22-14; IC 36-8-17

**Sec. 73.** Delete the text of Section 607 and substitute to read as follows: **See the Indiana Elevator Code.** (*Fire Prevention and Building Safety Commission; 675 IAC 22-2.3-73*)

### **675 IAC 22-2.3-74 Section 609; commercial kitchen hoods**

Authority: IC 22-13-2-2  
Affected: IC 22-12-7; IC 22-13; IC 22-14; IC 36-8-17

**Sec. 74.** Delete the text of Section 609 and substitute to read: **See the Indiana Mechanical Code.** (*Fire Prevention and Building Safety Commission; 675 IAC 22-2.3-74*)

### **675 IAC 22-2.3-75 Section 703.2; opening protectives**

Authority: IC 22-13-2-2  
Affected: IC 22-12-7; IC 22-13; IC 22-14; IC 36-8-17

**Sec. 75.** Amend the first sentence of Section 703.2 to read as follows: **Opening protectives shall be maintained in accordance with the rules of the commission.** (*Fire Prevention and Building Safety Commission; 675 IAC 22-2.3-75*)

### **675 IAC 22-2.3-76 Section 703.2.1; signs**

Authority: IC 22-13-2-2  
Affected: IC 22-12-7; IC 22-13; IC 22-14; IC 36-8-17

**Sec. 76.** Change Section 703.2.1 to read as follows: **A sign shall be displayed permanently near or on each required fire door in letters not less than one (1) inch (25.4 mm) high to read as follows:**

(1) For doors designed to be kept normally open: **FIRE DOOR - DO NOT BLOCK.**

(2) For doors designed to be kept normally closed: **FIRE DOOR - KEEP CLOSED.**

**For the purposes of this section, fire door means an assembly which is part of an area or occupancy separation.** (*Fire Prevention and Building Safety Commission; 675 IAC 22-2.3-76*)

### **675 IAC 22-2.3-77 Section 704; floor openings and shafts**

Authority: IC 22-13-2-2  
Affected: IC 22-12-7; IC 22-13; IC 22-14; IC 36-8-17

**Sec. 77.** Delete Section 704 without substitution. (*Fire Prevention and Building Safety Commission; 675 IAC 22-2.3-77*)

### **675 IAC 22-2.3-78 Section 804.5; a natural cut tree**

Authority: IC 22-13-2-2  
Affected: IC 22-12-7; IC 22-13; IC 22-14; IC 36-8-17

**Sec. 78.** Add Section 804.5 to read as follows: **804.5 A natural cut tree.** At least two (2) working days prior to placing a natural cut tree in a public building the fire department having jurisdiction shall be notified. (*Fire Prevention and Building Safety Commission; 675 IAC 22-2.3-78*)

### **675 IAC 22-2.3-79 Section 806.2; wall and ceiling finish**

Authority: IC 22-13-2-2  
Affected: IC 22-12-7; IC 22-13; IC 22-14; IC 36-8-17

**Sec. 79.** Amend Section 806.2 by adding "Section 803 of" after "with" and before "the" in the first sentence. (*Fire Prevention and Building Safety Commission; 675 IAC 22-2.3-79*)

### **675 IAC 22-2.3-80 Section 901.2; construction documents**

Authority: IC 22-13-2-2  
Affected: IC 22-12-7; IC 22-13; IC 22-14; IC 36-8-17

**Sec. 80.** Amend Section 901.2 to read as follows: **Complete plans and specifications for fire alarm systems; fire-extinguishing systems, including automatic sprinklers and wet dry standpipes; halon systems and other special types of automatic fire-extinguishing systems; basement pipeinlets; and other fire-protection systems and appurtenances thereto shall be submitted for review prior to system installation in accordance with 675 IAC 12-6 and with the local unit of government where required by local ordinance. Plans and specifications for fire alarm systems shall include, but not be limited to, a floor plan; location of all alarm-initiating and alarm-signaling devices; alarm control and trouble-signaling equipment; annuncuatuon; power connection; battery calculations; conductor type and sizes; voltage drop calculations; and manufacturer, model numbers and listing information for all equipment, devices and materials.** (*Fire Prevention and Building Safety Commission; 675 IAC 22-2.3-80*)

### **675 IAC 22-2.3-81 Section 901.2.1; statement of compliance**

Authority: IC 22-13-2-2  
Affected: IC 22-12-7; IC 22-13; IC 22-14; IC 36-8-17

**Sec. 81.** In Section 901.2.1, delete "where required by the code official". (*Fire Prevention and Building Safety Commission; 675 IAC 22-2.3-81*)

### **675 IAC 22-2.3-82 Section 901.3; permits**

Authority: IC 22-13-2-2  
Affected: IC 22-12-7; IC 22-13; IC 22-14; IC 36-8-17

**Sec. 82.** Delete Section 901.3 without substitution. (*Fire Prevention and Building Safety Commission; 675 IAC 22-2.3-82*)

**675 IAC 22-2.3-83 Section 901.4; installation**

Authority: IC 22-13-2-2  
Affected: IC 22-12-7; IC 22-13; IC 22-14; IC 36-8-17

**Sec. 83. In Section 901.4, delete text after the first sentence and substitute to read as follows: Alterations to fire protection systems shall be done in accordance with the applicable rules of the commission. (Fire Prevention and Building Safety Commission; 675 IAC 22-2.3-83)**

**675 IAC 22-2.3-84 Section 901.4.3; additional fire protection systems**

Authority: IC 22-13-2-2  
Affected: IC 22-12-7; IC 22-13; IC 22-14; IC 36-8-17

**Sec. 84. Delete Section 901.4.3 without substitution. (Fire Prevention and Building Safety Commission; 675 IAC 22-2.3-84)**

**675 IAC 22-2.3-85 Section 901.5; installation acceptance testing**

Authority: IC 22-13-2-2  
Affected: IC 22-12-7; IC 22-13; IC 22-14; IC 36-8-17

**Sec. 85. In Section 901.5, delete “and as approved by the code official”. (Fire Prevention and Building Safety Commission; 675 IAC 22-2.3-85)**

**675 IAC 22-2.3-86 Section 901.7; systems out of service**

Authority: IC 22-13-2-2  
Affected: IC 22-12-7; IC 22-13; IC 22-14; IC 36-8-17

**Sec. 86. In Section 901.7, delete “where required by the code official”. (Fire Prevention and Building Safety Commission; 675 IAC 22-2.3-86)**

**675 IAC 22-2.3-87 Section 902; definitions**

Authority: IC 22-13-2-2  
Affected: IC 22-12-7; IC 22-13; IC 22-14; IC 36-8-17

**Sec. 87. In Section 902, make the following changes:**  
**(1) Change the definition of ALARM SIGNAL to read as follows: ALARM SIGNAL. An audible or visual signal, indicating the existence of an emergency requiring immediate action.**

**(2) Add the following definition to read as follows:**  
**ADULT LEVEL 3, 4 OR 5 SECURITY. A maximum of high-medium security assignment constituting an assignment of convicted adult to a penal facility and correctional program that are designed to insure that the person remains within a walled or fenced facility where entry and exit of any person occurs only through supervised gates and where periodic inmate population accounting and supervision occurs each day.**  
**LABELED. Equipment or materials to which has been attached a label, symbol, or other identifying mark of an organization engaged in product evaluation, that maintains periodic inspection or production of labeled equipment or materials and by whose labeling the**

**manufacturer indicates compliance with appropriate standards or performance in a specified manner.**

**MAXIMUM SECURITY FACILITY (LEVEL I) Facility has cells designed for individual occupancy for long-term treatment and short-term intervention during periods of disruptive behavior. Offenders are assigned to these facilities if they are classified as Very High Risk, High Risk or are committed on a Determinant Sentence by the court. All offender programs are provided at the facility location until students enter the transition phase of the program or participate in a supervised off-ground program.**

**MEDIUM SECURITY FACILITY (LEVEL II) Facility has cells designed for individual occupancy during periods of disruptive behavior. Offenders are assigned to these facilities if they are classified as Medium Risk. All offender programs are provided at the facility location until students enter the transition phase of the program or participate in a supervised off-ground program.**

**TIRES, BULK STORAGE OF: Storage of tires where the area available for storage exceeds 20,000 cubic feet (566 mm<sup>3</sup>).**

**(3) Delete the definition of RECORD DRAWINGS. (Fire Prevention and Building Safety Commission; 675 IAC 22-2.3-87)**

**675 IAC 22-2.3-88 Section 903.2.1.3; Group A-3**

Authority: IC 22-13-2-2  
Affected: IC 22-12-7; IC 22-13; IC 22-14; IC 36-8-17

**Sec. 88. Change Section 903.2.1.3 Group A-3 as follows: (1) Change “Exception” to read “Exception 1:”.**

**(2) Add Exception 2 to read as follows: Exception 2. Fire areas having all the following; less than 1,000 occupants, one hour minimum fire resistive construction, and the main floor located at the same level as the level of exit discharge of the main entrance and exit.**

**(Fire Prevention and Building Safety Commission; 675 IAC 22-2.3-88)**

**675 IAC 22-2.3-89 Section 903.3.1.1.1; exempt locations**

Authority: IC 22-13-2-2  
Affected: IC 22-12-7; IC 22-13; IC 22-14; IC 36-8-17

**Sec. 89. Change Section 903.3.1.1.1 Exempt Locations as follows:**

**(1) Delete item 5 and substitute the following: Elevator equipment rooms and hoistways used exclusively for the operation of elevators and which are separated from the remainder of the building by two (2) hour fire resistive construction. Penetrations between machine rooms and hoistways necessary for the safe operation of an elevator and vents required by Section 3004 of this code need not be fire-rated.**

**(2) Add item 6 to read as follows: 6. Adult prison cells of**

## Proposed Rules

**Adult Level 3, 4 or 5 security, Maximum Security Facility (Level I), or Medium Security (Level II).**

*(Fire Prevention and Building Safety Commission; 675 IAC 22-2.3-89)*

**675 IAC 22-2.3-90 Section 903.3.1.2; NFPA 13R sprinkler systems**

Authority: IC 22-13-2-2

Affected: IC 22-12-7; IC 22-13; IC 22-14; IC 36-8-17

**Sec. 90. In Section 903.3.1.2, add "Occupancies" after "Group R".** *(Fire Prevention and Building Safety Commission; 675 IAC 22-2.3-90)*

**675 IAC 22-2.3-91 Section 903.3.5.1.1; limited area sprinkler systems**

Authority: IC 22-13-2-2

Affected: IC 22-12-7; IC 22-13; IC 22-14; IC 36-8-17

**Sec. 91. In the EXCEPTION for Section 903.3.5.1.1 limited area sprinkler systems, delete "an approved" to and insert "a listed".** *(Fire Prevention and Building Safety Commission; 675 IAC 22-2.3-91)*

**675 IAC 22-2.3-92 Section 903.3.6; hose threads**

Authority: IC 22-13-2-2

Affected: IC 22-12-7; IC 22-13; IC 22-14; IC 36-8-17

**Sec. 92. Amend Section 903.3.6 to read as follows: Fire hose threads used in connection with automatic sprinkler systems shall be compatible with the equipment used by the servicing fire department.** *(Fire Prevention and Building Safety Commission; 675 IAC 22-2.3-92)*

**675 IAC 22-2.3-93 Section 903.3.7; fire department connections**

Authority: IC 22-13-2-2

Affected: IC 22-12-7; IC 22-13; IC 22-14; IC 36-8-17

**Sec. 93. Change Section 903.3.7 Fire department connections to read as follows: The servicing fire department shall be consulted before placing the fire department hose connections at specific locations or the connections shall be placed as required by local ordinance.** *(Fire Prevention and Building Safety Commission; 675 IAC 22-2.3-93)*

**675 IAC 22-2.3-94 Section 903.4.2; alarms**

Authority: IC 22-13-2-2

Affected: IC 22-12-7; IC 22-13; IC 22-14; IC 36-8-17

**Sec. 94. Change Section 903.4.2 Alarms to read as follows: Listed audible and visible devices shall be connected to every automatic sprinkler system. Such sprinkler water-flow alarm devices shall be activated by water flow equivalent to the flow of a single sprinkler of the smallest orifice size installed in the system. Alarm devices shall be provided on the exterior of the building facing the public street, road or highway that is in accordance with its legal address.**

Where buildings are not directly facing the public street, road or highway or are in excess of 250 feet from the public street, road or highway, the servicing fire department shall be consulted in determining a location prior to the installation of the exterior audible and visible device. Where a fire alarm system is installed, actuation of the automatic sprinkler system shall actuate the building fire alarm system.

**EXCEPTION: Sprinkler systems which are monitored by an approved supervisory station are not required to have the listed audible and visible device located on the exterior wall facing the public street, road or highway.**

*(Fire Prevention and Building Safety Commission; 675 IAC 22-2.3-94)*

**675 IAC 22-2.3-95 Section 903.4.3; floor control valves**

Authority: IC 22-13-2-2

Affected: IC 22-12-7; IC 22-13; IC 22-14; IC 36-8-17

**Sec. 95. Change Section 903.4.3 Floor control valves as follows:**

**(1) Change "approved" to "a listed".**

**(2) Change "high-rise buildings" to "buildings 4 stories or more in height".**

*(Fire Prevention and Building Safety Commission; 675 IAC 22-2.3-95)*

**675 IAC 22-2.3-96 Section 903.6; existing buildings**

Authority: IC 22-13-2-2

Affected: IC 22-12-7; IC 22-13; IC 22-14; IC 36-8-17

**Sec. 96. Delete Section 903.6 without substitution.** *(Fire Prevention and Building Safety Commission; 675 IAC 22-2.3-96)*

**675 IAC 22-2.3-97 Section 904.2; where required**

Authority: IC 22-13-2-2

Affected: IC 22-12-7; IC 22-13; IC 22-14; IC 36-8-17

**Sec. 97. In Section 904.2, delete "approved by the code official" and insert "in accordance with the rules of the commission".** *(Fire Prevention and Building Safety Commission; 675 IAC 22-2.3-97)*

**675 IAC 22-2.3-98 Section 904.2.1; hood system suppression**

Authority: IC 22-13-2-2

Affected: IC 22-12-7; IC 22-13; IC 22-14; IC 36-8-17

**Sec. 98. In Section 904.2.1, delete "this code" and insert "Indiana Mechanical Code".** *(Fire Prevention and Building Safety Commission; 675 IAC 22-2.3-98)*

**675 IAC 22-2.3-99 Section 904.11; commercial cooking systems**

Authority: IC 22-13-2-2

Affected: IC 22-12-7; IC 22-13; IC 22-14; IC 36-8-17

**Sec. 99. Delete the last sentence of Section 904.11 Com-**

mercial cooking systems and substitute as follows: Automatic fire-extinguishing systems, for new installations, shall be installed in accordance with the Indiana Mechanical Code (675 IAC 18). (*Fire Prevention and Building Safety Commission; 675 IAC 22-2.3-99*)

**675 IAC 22-2.3-100** Section 904.11.1, Section 904.11.2, Section 904.11.3, Section 904.11.4; manual system operation, system interconnection, carbon dioxide systems, special provisions for automatic sprinkler systems

Authority: IC 22-13-2-2  
Affected: IC 22-12-7; IC 22-13; IC 22-14; IC 36-8-17

**Sec. 100.** Delete Sections 904.11.1 through 904.11.4 and substitute: See the Indiana Mechanical Code (675 IAC 18). (*Fire Prevention and Building Safety Commission; 675 IAC 22-2.3-100*)

**675 IAC 22-2.3-101** Section 904.11.5; commercial cooking equipment

Authority: IC 22-13-2-2  
Affected: IC 22-12-7; IC 22-13; IC 22-14; IC 36-8-17

**Sec. 101.** Delete the text of Section 904.11.5 and substitute to read as follows: Alkaline dry chemical-type portable fire extinguishers shall be installed in the kitchen area for the protection of the cooking equipment. Extinguishers shall have a minimum rating of forty (40) B (sodium bicarbonate or potassium bicarbonate base) and shall be conspicuously located and readily accessible along exit paths from the area. The extinguishers shall be a minimum of ten (10) feet and maximum of twenty (20) feet from the cooking equipment. The top of the extinguishers shall be a maximum of five (5) feet above the floor and shall be protected from physical damage. Cooking equipment involving vegetable or animal oils and fats shall be protected by a Class K rated portable extinguisher.

**EXCEPTION:** If portable fire extinguishers were not required at the time of installation of the cooking equipment, they shall be installed in accordance with the current Indiana Mechanical Code (675 IAC 18).

(*Fire Prevention and Building Safety Commission; 675 IAC 22-2.3-101*)

**675 IAC 22-2.3-102** Section 904.11.6.1, 904.11.6.2, 904.11.6.3, 904.11.6.4, 904.11.6.5; ventilation system, grease extractors, cleaning, extinguishing system service, fusible link and sprinkler head replacement

Authority: IC 22-13-2-2  
Affected: IC 22-12-7; IC 22-13; IC 22-14; IC 36-8-17

**Sec. 102.** Delete Sections 904.11.6.1 through 904.11.6.5 and substitute to read as follows:

**904.11.6.1** If grease extractors are installed, they shall be operated when the commercial food heat-processing equipment is used.

Extinguishing systems shall be inspected and serviced at least every six (6) months or after activation of the system. Inspection and servicing shall be by qualified individuals, and a service and inspection report shall be left at the site. A Certificate of Inspection shall be forwarded to the chief of the fire department having jurisdiction upon completion of servicing or inspection. All inspections performed shall be to the code in effect at the time of installation, alteration, or modification.

Fusible links, sprinklers, and automatic spray nozzles shall be replaced at least annually, or more frequently if necessary, to ensure proper operation of the system, and other protection devices shall be serviced or replaced in accordance with the manufacturer's instructions.

**EXCEPTION 1.** Frangible bulbs need not be replaced annually.

**EXCEPTION 2.** When automatic bulb-type sprinklers or spray nozzles are used and an annual examination shows no buildup of grease or other material on the sprinkler or spray nozzle.

Hoods, grease-removal devices, fans, ducts, and other appurtenances shall be cleaned at frequent intervals in accordance with section 1006.1.

**904.11.6.2** Exhaust systems with Type I hoods shall be installed in accordance with the mechanical code in effect at the time of installation or alteration, and maintained in accordance with the conditions of labeling (if labeled), the manufacturer's instructions and the following:

(1) A cleaning schedule shall be posted on site for every exhaust system with a Type I hood. The schedule shall indicate methods of cleaning and the time interval between cleaning.

(2) Surfaces subject to oil or grease deposits shall be cleaned to bare metal at intervals frequent enough to prevent oil or grease deposits from exceeding a thickness of twenty-five thousandths (0.025) inch. Exhaust systems with Type I hoods shall be inspected by a qualified person at least every six (6) months.

(3) Flammable solvents or other flammable cleaning agents shall not be used.

(4) Care shall be taken not to apply cleaning chemicals to fusible links or other detection devices of the fire-extinguishing equipment.

(5) At the start of the cleaning process, electrical switches shall be locked out. **WHEN CLEANING PROCEDURES ARE COMPLETED, ALL ELECTRICAL SWITCHES, DETECTION DEVICES, AND SYSTEM COMPONENTS SHALL BE RETURNED TO AN OPERABLE CONDITION BY QUALIFIED PERSONNEL.**

## Proposed Rules

(6) Records of cleaning, maintenance, and inspections shall be maintained on site for a period of three (3) years, and a certificate of inspection shall be forwarded to the chief of the fire department having jurisdiction upon completion.

**EXCEPTION:** Where the local health official or the Indiana Department of Health has more stringent cleaning requirements than those stated above, they shall take precedence over these requirements.

**904.11.6.2.1 Existing Equipment.** Exhaust systems with Type I hoods installed prior to the effective date of this code shall be maintained in accordance with the mechanical code in effect when the exhaust system with a Type I hood was installed.

**EXCEPTION:** All exhaust systems with Type I hoods shall be cleaned in accordance with the requirements of this section.

**904.11.6.3 Where Required.** Fire-extinguishing equipment for Type I hoods shall be installed in accordance with the Indiana Mechanical Code (675 IAC 18) in effect at the time of installation, and maintained in accordance with section 904.11.6.1 of this code.

**EXCEPTION:** Fire-extinguishing systems for Type I hoods that serve deep fat fryers and other cooking appliances shall be either a system listed for application with such equipment or an automatic fire-extinguishing system that is specifically designed for such application.

*(Fire Prevention and Building Safety Commission; 675 IAC 22-2.3-102)*

### **675 IAC 22-2.3-103 Section 905.2; installation standards**

Authority: IC 22-13-2-2

Affected: IC 22-12-7; IC 22-13; IC 22-14; IC 36-8-17

**Sec. 103.** Add an exception to 905.2 to read as follows: **Exception:** In other than high rise buildings where buildings are sprinklered in accordance with Section 903.3.1.1, the water supply pressure for the standpipe system is not required to exceed the pressure requirements for the sprinkler system. *(Fire Prevention and Building Safety Commission; 675 IAC 22-2.3-103)*

### **675 IAC 22-2.3-104 Section 905.2.1; fire department connections**

Authority: IC 22-13-2-2

Affected: IC 22-12-7; IC 22-13; IC 22-14; IC 36-8-17

**Sec. 104.** Add Section 905.2.1 after 905.2 to read as follows: **905.2.1 Fire Department connections.** The location of fire department connections shall be in accordance with Section 903.3.7. *(Fire Prevention and Building Safety Commission; 675 IAC 22-2.3-104)*

### **675 IAC 22-2.3-105 Section 905.3.5.1; hose and cabinet**

Authority: IC 22-13-2-2

Affected: IC 22-12-7; IC 22-13; IC 22-14; IC 36-8-17

**Sec. 105.** Delete Section 905.3.5.1 Hose and cabinet and substitute to read as follows: Proper cap and chain shall be provided for the hose connection valve assembly. Hose connection valve assembly shall comply with the provisions in Section 903.3.6. *(Fire Prevention and Building Safety Commission; 675 IAC 22-2.3-105)*

### **675 IAC 22-2.3-106 Section 905.4; location of Class I standpipe connections**

Authority: IC 22-13-2-2

Affected: IC 22-12-7; IC 22-13; IC 22-14; IC 36-8-17

**Sec. 106.** Change Section 905.4 Location of Class I standpipe hose connections as follows:

(1) Delete item 1 and substitute as follows: 1. In every required stairway, a hose connection shall be provided for each floor level above or below grade. Hose connections shall be located at an intermediate floor level landing between floors. Where there are multiple intermediate floor landings between floors, hose connections shall be located at the landing closest to being midway between floors. If intermediate floor level landings are not provided in the required stairway, the hose connection shall be located on the floor-level landing.

(2) Delete item 6 and substitute as follows: 6. Where the most remote portion of a non-sprinklered floor or story is more than 150 feet from a hose connection or the most remote portion of a sprinklered floor or story is 200 feet from a hose connection, additional hose connections shall be provided in exit passageways which are 1-hour rated.

*(Fire Prevention and Building Safety Commission; 675 IAC 22-2.3-106)*

### **675 IAC 22-2.3-107 Section 905.8; dry standpipes**

Authority: IC 22-13-2-2

Affected: IC 22-12-7; IC 22-13; IC 22-14; IC 36-8-17

**Sec. 107.** Change Section 905.8 Dry standpipes to read as follows: In buildings requiring standpipes, dry standpipes complying with NFPA 14 are permitted when, the building or structure is unheated and the standpipe is subject to freezing temperatures. *(Fire Prevention and Building Safety Commission; 675 IAC 22-2.3-107)*

### **675 IAC 22-2.3-108 Section 906.1; where required**

Authority: IC 22-13-2-2

Affected: IC 22-12-7; IC 22-13; IC 22-14; IC 36-8-17

**Sec. 108.** Delete Section 906.1 and substitute to read as follows: Portable fire extinguishers shall be installed where required by TABLE 906.1 and where required by local ordinance. *(Fire Prevention and Building Safety Commission; 675 IAC 22-2.3-108)*

### **675 IAC 22-2.3-109 Section 907.1.1; construction documents**

Authority: IC 22-13-2-2

Affected: IC 22-12-7; IC 22-13; IC 22-14; IC 36-8-17

**Sec. 109.** Delete the text of Section 907.1.1 Construction documents and substitute to read as follows: See the General Administrative Rules (675 IAC 12-6). (*Fire Prevention and Building Safety Commission; 675 IAC 22-2.3-109*)

**675 IAC 22-2.3-110** Section 907.2.1.1; system initiation in Group A occupancies with an occupant load of 1,000 or more

Authority: IC 22-13-2-2  
Affected: IC 22-12-7; IC 22-13; IC 22-14; IC 36-8-17

**Sec. 110.** Delete the Exception to Section 907.2.1.1 System initiation in Group A occupancies with an occupant load of 1,000 or more. (*Fire Prevention and Building Safety Commission; 675 IAC 22-2.3-110*)

**675 IAC 22-2.3-111** Section 907.2.3; Group E

Authority: IC 22-13-2-2  
Affected: IC 22-12-7; IC 22-13; IC 22-14; IC 36-8-17

**Sec. 111.** Change Section 907.2.3 Group E as follows:  
(1) Delete EXCEPTION 2.3 and substitute to read as follows: 2.3 Shops and laboratories involving dust or vapors are protected by heat detectors or other listed detection devices.

(2) Delete in EXCEPTION 2.6, “, except in locations specifically designated by the building official”.

(*Fire Prevention and Building Safety Commission; 675 IAC 22-2.3-111*)

**675 IAC 22-2.3-112** Section 907.2.10.1.1.1; R1 hotels and motels

Authority: IC 22-13-2-2  
Affected: IC 22-12-7; IC 22-13; IC 22-14; IC 36-8-17

**Sec. 112.** Add Section 907.2.10.1.1.1 after Section 907.2.10.1.1 as follows: 907.2.10.1.1.1 R1 Hotels and Motels.

(1) This Section only applies to hotels and motels.  
(2) All hotels and motels must have functional smoke detectors and comply with this Section and Section 907.2.10.1.1

(3) Except as provided in (6), a detector must be installed in all interior corridors adjacent to sleeping rooms and must be spaced no further apart than thirty (30) feet on center or more than fifteen (15) feet from any wall.

(4) The detectors must be hard wired into a building’s electrical system, except as provided in (6).

(5) The detectors must be wired in a manner that activates all the devices in a corridor when one is activated, except as provided in (6).

(6) All single level dwellings, all seasonably occupied dwellings, and all hotels and motels with twelve (12) sleeping rooms or less (and containing no interior corridors) are exempt from the requirements of (3), (4), and (5). In such units:

- (A) a detector must be installed in each sleeping room; and
- (B) the detector may be battery operated, when allowed by section 907.2.10.2.

If a battery operated detector is installed, it must contain a tamper resistant cover to protect the batteries.

For the purpose of Section 907.2.10.1.1.1, the following definitions shall apply:

**DWELLING** means a residence with at least one (1) dwelling unit as set forth in IC 22-12-1-4(a)(1)(B) and IC 22-12-1-5(a)(1).

**HOTELS AND MOTELS** means buildings or structures kept, maintained, used, advertised, or held out to the public as inns or places where sleeping accommodations are furnished for hire for transient guest.

**SEASONALLY OCCUPIED DWELLINGS** means hotels and motels open to the public for occupancy by guests only during any period of time between April 15 and October 15 each year.

**SINGLE LEVEL DWELLING** means all single level (no more than one (1) level above ground) hotels and motels that have no interior corridors, and whose individual rooms have exterior exits.

(*Fire Prevention and Building Safety Commission; 675 IAC 22-2.3-112*)

**675 IAC 22-2.3-113** Section 907.2.10.1.2; Groups R-2, R-3, R-4 and I-1

Authority: IC 22-13-2-2  
Affected: IC 22-12-7; IC 22-13; IC 22-14; IC 36-8-17

**Sec. 113.** In Section 907.2.10.1.2, delete “and maintained”. (*Fire Prevention and Building Safety Commission; 675 IAC 22-2.3-113*)

**675 IAC 22-2.3-114** Section 907.2.10.1.4; additions, alterations or repairs to Group R

Authority: IC 22-13-2-2  
Affected: IC 22-12-7; IC 22-13; IC 22-14; IC 36-8-17

**Sec. 114.** Change the Exception to Section 907.2.10.1.4 to read as follows: **Exception: Repairs are exempt from the requirements of this section.** (*Fire Prevention and Building Safety Commission; 675 IAC 22-2.3-114*)

**675 IAC 22-2.3-115** Section 907.2.15; special egress-control devices

Authority: IC 22-13-2-2  
Affected: IC 22-12-7; IC 22-13; IC 22-14; IC 36-8-17

**Sec. 115.** Amend Section 907.2.15 by changing the test to read: **When special egress-control devices or systems are installed, such devices or systems shall be maintained in accordance with the building code requirements for the original installation.** (*Fire Prevention and Building Safety Commission; 675 IAC 22-2.3-115*)

**675 IAC 22-2.3-116** Section 907.3; where required-retroactive in existing buildings and structures

Authority: IC 22-13-2-2  
Affected: IC 22-12-7; IC 22-13; IC 22-14; IC 36-8-17

**Sec. 116.** Delete in Section 907.3 Where required -

## Proposed Rules

retroactive in existing buildings and structures without substitution. (*Fire Prevention and Building Safety Commission; 675 IAC 22-2.3-116*)

**675 IAC 22-2.3-117 Section 907.4.5; protective covers**

Authority: IC 22-13-2-2

Affected: IC 22-12-7; IC 22-13; IC 22-14; IC 36-8-17

**Sec. 117. Delete Section 907.4.5 Protective Covers and substitute to read as follows: Listed manual fire alarm box protective covers may be installed when approved.** (*Fire Prevention and Building Safety Commission; 675 IAC 22-2.3-117*)

**675 IAC 22-2.3-118 Section 907.8 Presignal system**

Authority: IC 22-13-2-2

Affected: IC 22-12-7; IC 22-13; IC 22-14; IC 36-8-17

**Sec. 118. Delete Section 907.8 without substitution.** (*Fire Prevention and Building Safety Commission; 675 IAC 22-2.3-118*)

**675 IAC 22-2.3-119 Section 907.9.1; zoning indicator panel**

Authority: IC 22-13-2-2

Affected: IC 22-12-7; IC 22-13; IC 22-14; IC 36-8-17

**Sec. 119. Change Section 907.9.1 Zoning indicator panel to read as follows: A zoning indicator panel and associated controls shall be provided in a location the servicing fire department will use as their main entrance point to the building. The panel shall be identifiable and accessible at all times. The visual zone indication shall lock in until the system is reset and shall not be canceled by the operation of an audible alarm-silencing switch.** (*Fire Prevention and Building Safety Commission; 675 IAC 22-2.3-119*)

**675 IAC 22-2.3-120 Section 907.10.1.1; public and common area**

Authority: IC 22-13-2-2

Affected: IC 22-12-7; IC 22-13; IC 22-14; IC 36-8-17

**Sec. 120. Amend Section 907.1.1 by adding the word “areas” after the word “public”.** (*Fire Prevention and Building Safety Commission; 675 IAC 22-2.3-120*)

**675 IAC 22-2.3-121 Section 907.15; monitoring**

Authority: IC 22-13-2-2

Affected: IC 22-12-7; IC 22-13; IC 22-14; IC 36-8-17

**Sec. 121. Change Section 907.15 Monitoring to read as follows: Where required by this chapter or by local ordinance, an approved supervising station in accordance with rules of the commission shall monitor fire alarm systems.** (*Fire Prevention and Building Safety Commission; 675 IAC 22-2.3-121*)

**675 IAC 22-2.3-122 Section 907.16; automatic telephone-dialing devices**

Authority: IC 22-13-2-2

Affected: IC 22-12-7; IC 22-13; IC 22-14; IC 36-8-17

**Sec. 122. Change Section 907.16 Automatic telephone-dialing devices to read as follows: Automatic telephone-dialing devices used to transmit an emergency alarm shall not be connected to any fire department telephone number unless approved by the code official.** (*Fire Prevention and Building Safety Commission; 675 IAC 22-2.3-122*)

**675 IAC 22-2.3-123 Section 907.18; record of completion**

Authority: IC 22-13-2-2

Affected: IC 22-12-7; IC 22-13; IC 22-14; IC 36-8-17

**Sec. 123. Delete Section 907.18 Record of completion without substitution.** (*Fire Prevention and Building Safety Commission; 675 IAC 22-2.3-123*)

**675 IAC 22-2.3-124 Section 907.19; instructions**

Authority: IC 22-13-2-2

Affected: IC 22-12-7; IC 22-13; IC 22-14; IC 36-8-17

**Sec. 124. Delete Section 907.19 Instructions without substitution.** (*Fire Prevention and Building Safety Commission; 675 IAC 22-2.3-124*)

**675 IAC 22-2.3-125 Section 907.20.1; maintenance record**

Authority: IC 22-13-2-2

Affected: IC 22-12-7; IC 22-13; IC 22-14; IC 36-8-17

**Sec. 125. Change Section 907.20.1 by deleting “applicable NFPA requirements or as directed by the code official” and substituting “the rules of the commission”.** (*Fire Prevention and Building Safety Commission; 675 IAC 22-2.3-125*)

**675 IAC 22-2.3-126 Section 907.20.2; testing**

Authority: IC 22-13-2-2

Affected: IC 22-12-7; IC 22-13; IC 22-14; IC 36-8-17

**Sec. 126. In Section 907.20.2, delete all the text after “NFPA 72”.** (*Fire Prevention and Building Safety Commission; 675 IAC 22-2.3-126*)

**675 IAC 22-2.3-127 Section 909.2; general design requirements**

Authority: IC 22-13-2-2

Affected: IC 22-12-7; IC 22-13; IC 22-14; IC 36-8-17

**Sec. 127. Change Section 909.2 General design requirements to read as follows: Buildings, structures, or parts thereof required by this code to have a smoke control system or systems shall have such systems designed in accordance with the applicable requirements of Section 909 and the generally accepted and well-established principles of engineering relevant to the design. Construction documents shall be as required by the General Administrative Rules (675 IAC 12-6).** (*Fire Prevention and Building Safety Commission; 675 IAC 22-2.3-127*)



**675 IAC 22-2.3-128 Section 909.3; special inspection and test requirements**

Authority: IC 22-13-2-2  
Affected: IC 22-12-7; IC 22-13; IC 22-14; IC 36-8-17

**Sec. 128. Delete Section 909.3 Special inspection and test requirements and substitute to read as follows: For inspections and testing, see the General Administrative Rules (675 IAC 12-6-6(c)(10)(D)).** *(Fire Prevention and Building Safety Commission; 675 IAC 22-2.3-128)*

**675 IAC 22-2.3-129 Section 909.10.2; ducts**

Authority: IC 22-13-2-2  
Affected: IC 22-12-7; IC 22-13; IC 22-14; IC 36-8-17

**Sec. 129. In the third sentence of Section 909.10.2 Ducts, delete “nationally” and substitute “approved”.** *(Fire Prevention and Building Safety Commission; 675 IAC 22-2.3-129)*

**675 IAC 22-2.3-130 Section 909.15; control diagrams**

Authority: IC 22-13-2-2  
Affected: IC 22-12-7; IC 22-13; IC 22-14; IC 36-8-17

**Sec. 130. Change Section 909.15 Control diagrams to read as follows: Identical control diagrams showing all devices in the system and identifying their location and function shall be maintained current and kept on file with the building official, the servicing fire department and in the fire command center in an approved manner and format.** *(Fire Prevention and Building Safety Commission; 675 IAC 22-2.3-130)*

**675 IAC 22-2.3-131 Section 909.18.8 and Section 909.18.9; special inspections for smoke control and identification and documentation**

Authority: IC 22-13-2-2  
Affected: IC 22-12-7; IC 22-13; IC 22-14; IC 36-8-17

**Sec. 131. Delete Sections 909.18.8 Special inspections for smoke control; and 909.18.9 Identification and documentation and substitute: See the General Administrative Rules (675 IAC 12-6-6(c)(10)(D)).** *(Fire Prevention and Building Safety Commission; 675 IAC 22-2.3-131)*

**675 IAC 22-2.3-132 Section 909.19; system acceptance**

Authority: IC 22-13-2-2  
Affected: IC 22-12-7; IC 22-13; IC 22-14; IC 36-8-17

**Sec. 132. Delete the title and text of Section 909.19 System acceptance and substitute to read as follows: 909.19 Acceptance test. Smoke removal systems shall be tested in accordance with the rules of the commission at the expense of the owner or owner’s representative. When requested by the servicing fire department and/or local building official, such tests shall be conducted in their presence. Prior to conducting such tests, the servicing fire department and/or local building official shall be given at least 48-hour notice. It shall be unlawful to occupy portions of the structure until**

**the required smoke removal system within that portion of the structure has been completed, successfully tested and fully operational with appropriate reports and other documentation provided to the servicing fire department and/or local building official.** *(Fire Prevention and Building Safety Commission; 675 IAC 22-2.3-132)*

**675 IAC 22-2.3-133 Section 910.2.1; Groups F-1 and S-1**

Authority: IC 22-13-2-2  
Affected: IC 22-12-7; IC 22-13; IC 22-14; IC 36-8-17

**Sec. 133. Add an Exception to Section 910.2.1 Groups F-1 and S-1 to read as follows: Exception: Group S-1 Aircraft Hangers.** *(Fire Prevention and Building Safety Commission; 675 IAC 22-2.3-133)*

**675 IAC 22-2.3-134 Section 910.3.1.2; sprinklered buildings**

Authority: IC 22-13-2-2  
Affected: IC 22-12-7; IC 22-13; IC 22-14; IC 36-8-17

**Sec. 134. Delete Section 910.3.1.2 Sprinklered buildings and substitute to read as follows: Where installed in buildings equipped with an approved automatic sprinkler system, smoke and heat vents shall open by approved manual releases. The servicing fire department shall be consulted in determining location of such manual releases prior to the installation of the smoke and heat vents.** *(Fire Prevention and Building Safety Commission; 675 IAC 22-2.3-134)*

**675 IAC 22-2.3-135 Section 910.3.4; curtain boards**

Authority: IC 22-13-2-2  
Affected: IC 22-12-7; IC 22-13; IC 22-14; IC 36-8-17

**Sec. 135. Add an Exception to the end of Section 910.3.4 Curtain boards to read as follows: Exception: Where areas of buildings are equipped with early suppression-fast response (ESFR) sprinklers, curtains boards shall not be provided within these areas. Curtains boards shall be provided at the separation between the ESFR sprinklers and the conventional sprinklers and in other areas as required by this section.** *(Fire Prevention and Building Safety Commission; 675 IAC 22-2.3-135)*

**675 IAC 22-2.3-136 Section 910.4; mechanical smoke exhaust**

Authority: IC 22-13-2-2  
Affected: IC 22-12-7; IC 22-13; IC 22-14; IC 36-8-17

**Sec. 136. Delete Section 910.4 and substitute to read as follows: In buildings protected throughout with an approved automatic sprinkler system, manually operated exhaust fans may be utilized for fire department mop-up operations. The exhaust rate shall be equal to 1 cfm per square foot of floor area. The fans shall be wired ahead of the main building disconnect switch. Manual controls for the fans shall be provided individually for each fan unit.**

## Proposed Rules

The servicing fire department shall be consulted in determining the location of the controls for the exhaust fans. (*Fire Prevention and Building Safety Commission; 675 IAC 22-2.3-136*)

### 675 IAC 22-2.3-137 Section 1001.2; minimum requirements

Authority: IC 22-13-2-2  
Affected: IC 22-12-7; IC 22-13; IC 22-14; IC 36-8-17

Sec. 137. Delete Section 1001.2 Minimum requirements and substitute to read as follows: See the General Administrative Rules (675 IAC 12). (*Fire Prevention and Building Safety Commission; 675 IAC 22-2.3-137*)

### 675 IAC 22-2.3-138 Section 1002; definitions

Authority: IC 22-13-2-2  
Affected: IC 22-12-7; IC 22-13; IC 22-14; IC 36-8-17

Sec. 138. Add in Section 1002 the definition of ICC/ANSI A117.1 after the definition of HANDRAIL to read as follows: ICC/ANSI A117.1. Chapter 11 of the Indiana Building Code (675 IAC 13). (*Fire Prevention and Building Safety Commission; 675 IAC 22-2.3-138*)

### 675 IAC 22-2.3-139 Section 1003.2.2.4; increased occupant load

Authority: IC 22-13-2-2  
Affected: IC 22-12-7; IC 22-13; IC 22-14; IC 36-8-17

Sec. 139. Delete Section 1003.2.2.4 Increased occupant load without substitution. (*Fire Prevention and Building Safety Commission; 675 IAC 22-2.3-139*)

### 675 IAC 22-2.3-140 Section 1003.2.13.1; general

Authority: IC 22-13-2-2  
Affected: IC 22-12-7; IC 22-13; IC 22-14; IC 36-8-17

Sec. 140. Delete in Section 1003.2.13.1 General the words "one or more" and substitute the words "at least one". (*Fire Prevention and Building Safety Commission; 675 IAC 22-2.3-140*)

### 675 IAC 22-2.3-141 Section 1003.3.1.1; size of doors

Authority: IC 22-13-2-2  
Affected: IC 22-12-7; IC 22-13; IC 22-14; IC 36-8-17

Sec. 141. Delete Exception 8 in Section 1003.3.1.1. Size of doors. (*Fire Prevention and Building Safety Commission; 675 IAC 22-2.3-141*)

### 675 IAC 22-2.3-142 Section 1003.3.1.4; floor elevation

Authority: IC 22-13-2-2  
Affected: IC 22-12-7; IC 22-13; IC 22-14; IC 36-8-17

Sec. 142. Change in Section 1003.3.1.4 Floor elevation Exception 4 to read as follows: 4. Exterior decks, patios, or balconies that are part of a dwelling unit regulated under part 2 of Chapter 11 of the Indiana Building Code (675 IAC 13) and have impervious surfaces, and that are not more

than 4 inches (102 mm) below the finished floor level of the adjacent interior space of the dwelling unit. (*Fire Prevention and Building Safety Commission; 675 IAC 22-2.3-142*)

### 675 IAC 22-2.3-143 Section 1003.3.1.7; door arrangement

Authority: IC 22-13-2-2  
Affected: IC 22-12-7; IC 22-13; IC 22-14; IC 36-8-17

Sec. 143. Change in Section 1003.3.1.7 Door arrangement Exception 3 to read as follows: 3. Doors within individual dwelling units in Groups R-2 and R-3 as applicable in Section 1001.2. (*Fire Prevention and Building Safety Commission; 675 IAC 22-2.3-143*)

### 675 IAC 22-2.3-144 Section 1003.3.1.8; locks and latches

Authority: IC 22-13-2-2  
Affected: IC 22-12-7; IC 22-13; IC 22-14; IC 36-8-17

Sec. 144. Change Section 1003.3.1.8 Locks and latches as follows:

- (1) In Exception 2, 3, delete 2.3 without substitution.
- (2) Add Exception 5 to read as follows: 5. Licensed Health Care Facilities that comply with IC 22-11-17-2.5 but meeting the federal standards of certification for participation in a reimbursed program under either Title XVIII or Title XIX of the Federal Social Security Act.

(*Fire Prevention and Building Safety Commission; 675 IAC 22-2.3-144*)

### 675 IAC 22-2.3-145 Section 1003.3.1.8.2; delayed egress locks

Authority: IC 22-13-2-2  
Affected: IC 22-12-7; IC 22-13; IC 22-14; IC 36-8-17

Sec. 145. Delete in Section 1003.3.1.8.2 Delayed egress locks the Exception to item 4. (*Fire Prevention and Building Safety Commission; 675 IAC 22-2.3-145*)

### 675 IAC 22-2.3-146 Section 1003.3.3.3; stair treads

Authority: IC 22-13-2-2  
Affected: IC 22-12-7; IC 22-13; IC 22-14; IC 36-8-17

Sec. 146. Change Section 1003.3.3.3 Stair treads and risers as follows:

- (1) Delete Exception 5 and substitute to read as follows: 5. Within dwelling units in occupancies in Group R-3, as applicable in the Indiana Building Code (675 IAC 13), and within dwelling units in occupancies in Group R-2, as applicable in the Indiana Building Code (675 IAC 13), the maximum riser height shall be 8 ¼ inches (210 mm), the minimum tread depth shall be 9 inches (229 mm). A nosing not less than 0.75 inch (19.1 mm) but not more than 1.25 inches (32 mm) shall be provided on stairways with solid risers where the tread is less than 11 inches. In occupancies in Group U, which are accessory to an occupancy in Group R-3, as applicable in the Indiana Building Code (675 IAC 13), the maximum riser height

shall be 7.75 inches (197 mm) and the minimum tread depth shall be 10 inches (254 mm) and the nosing requirements shall remain the same as above.

(2) Delete Exception 6 and substitute to read: See the General Administrative Rules (675 IAC 12).

*(Fire Prevention and Building Safety Commission; 675 IAC 22-2.3-146)*

**675 IAC 22-2.3-147 Section 1003.3.3.9; spiral stairways**  
 Authority: IC 22-13-2-2  
 Affected: IC 22-12-7; IC 22-13; IC 22-14; IC 36-8-17

**Sec. 147. Delete the Exception in Section 1003.3.3.9 Spiral stairways.** *(Fire Prevention and Building Safety Commission; 675 IAC 22-2.3-147)*

**675 IAC 22-2.3-148 Section 1003.3.3.11.3; handrail graspability**  
 Authority: IC 22-13-2-2  
 Affected: IC 22-12-7; IC 22-13; IC 22-14; IC 36-8-17

**Sec. 148. Add an Exception to the end of Section 1003.3.3.11.3 to read as follows: Exception: Within Group R-2 dwelling units, the handgrip portion of handrails shall have a circular cross section of 1 ¼ inches (32 mm) minimum to 2 7/8 inches (73 mm) maximum. Other handrail shapes that provide equivalent grasping surface are permissible. Edges shall have a minimum radius of ⅛ inch (3.2 mm).** *(Fire Prevention and Building Safety Commission; 675 IAC 22-2.3-148)*

**675 IAC 22-2.3-149 Section 1008.10; seat stability**  
 Authority: IC 22-13-2-2  
 Affected: IC 22-12-7; IC 22-13; IC 22-14; IC 36-8-17

**Sec. 149. In Section 1008.10 Seat stability, delete the last sentence of Exception 4.** *(Fire Prevention and Building Safety Commission; 675 IAC 22-2.3-149)*

**675 IAC 22-2.3-150 Section 1009.6; exterior rescue access**  
 Authority: IC 22-13-2-2  
 Affected: IC 22-12-7; IC 22-13; IC 22-14; IC 36-8-17

**Sec. 150. Add Section 1009.6 Exterior rescue access to the end of Section 1009 to read as follows: 1009.6 Exterior Rescue Access. Exterior access for fire department use in performing rescue operations when emergency escape and rescue openings are required shall comply with Sections 1009.6.1 and 1009.6.2.**

**1009.6.1** The exterior grade adjacent to emergency escape and rescue openings shall not have a slope of more than 2 inches in 12 inches. The grade requirement shall extend from the structure to a point which will allow the placement of a fire department ground ladder to the sill of the emergency escape and rescue opening when such ladder is placed at a 75 degree angle maximum from the horizontal plane.

**1009.6.2** No obstructions such as wire, trees, shrubs, signs, cornices, overhangs, awnings, canopies, parking or other features shall be permitted.

**EXCEPTION:** Canopies and similar types of building features may be used as a portion of the rescue access system, if the slope of the canopy does not exceed 2 inches in 12 inches, and access as required in Section 1009.6.1 is provided from the ground to the top edge of the canopy.

*(Fire Prevention and Building Safety Commission; 675 IAC 22-2.3-150)*

**675 IAC 22-2.3-151 Section 1101.3; permits**  
 Authority: IC 22-13-2-2  
 Affected: IC 22-12-7; IC 22-13; IC 22-14; IC 36-8-17

**Sec. 151. Delete Section 1101.3 without substitution.** *(Fire Prevention and Building Safety Commission; 675 IAC 22-2.3-151)*

**675 IAC 22-2.3-152 Section 1105.3; on welding apparatus**  
 Authority: IC 22-13-2-2  
 Affected: IC 22-12-7; IC 22-13; IC 22-14; IC 36-8-17

**Sec. 152. Amend Section 1105.3 by deleting “10-B:C” and inserting “20-B:C”.** *(Fire Prevention and Building Safety Commission; 675 IAC 22-2.3-152)*

**675 IAC 22-2.3-153 Section 1106.3.3; dispensing hoses and nozzles**  
 Authority: IC 22-13-2-2  
 Affected: IC 22-12-7; IC 22-13; IC 22-14; IC 36-8-17

**Sec. 153. In the last sentence of Section 1106.3.3, delete “proper” and insert “approved”.** *(Fire Prevention and Building Safety Commission; 675 IAC 22-2.3-153)*

**675 IAC 22-2.3-154 Section 1106.3.6; accessory equipment**  
 Authority: IC 22-13-2-2  
 Affected: IC 22-12-7; IC 22-13; IC 22-14; IC 36-8-17

**Sec. 154. In Section 1106.3.6, delete “substantially”.** *(Fire Prevention and Building Safety Commission; 675 IAC 22-2.3-154)*

**675 IAC 22-2.3-155 Section 1106.3.7.1; bonding cables**  
 Authority: IC 22-13-2-2  
 Affected: IC 22-12-7; IC 22-13; IC 22-14; IC 36-8-17

**Sec. 155. Change Section 1106.3.7.1 as follows:**  
 (1) Delete “a substantial heavy-duty” and insert “an approved or listed”.  
 (2) Delete “a suitable” and insert “an approved or listed”.  
*(Fire Prevention and Building Safety Commission; 675 IAC 22-2.3-155)*

**675 IAC 22-2.3-156 Section 1106.3.7.2; bonding cable protection**  
 Authority: IC 22-13-2-2  
 Affected: IC 22-12-7; IC 22-13; IC 22-14; IC 36-8-17

## Proposed Rules

**Sec. 156.** Delete the last sentence of Section 1106.3.7.2. (*Fire Prevention and Building Safety Commission; 675 IAC 22-2.3-156*)

**675 IAC 22-2.3-157 Section 1106.5.2.3; funnels**

Authority: IC 22-13-2-2

Affected: IC 22-12-7; IC 22-13; IC 22-14; IC 36-8-17

**Sec. 157.** In Section 1106.5.2.3, delete “where required”. (*Fire Prevention and Building Safety Commission; 675 IAC 22-2.3-157*)

**675 IAC 22-2.3-158 Section 1106.6.4; testing**

Authority: IC 22-13-2-2

Affected: IC 22-12-7; IC 22-13; IC 22-14; IC 36-8-17

**Sec. 158.** Change the last sentence of Section 1106.6.4 to read as follows: **The fueling-system operator shall maintain a complete record of the last two (2) tests at all times, and the complete record be made available to the code official upon request.** (*Fire Prevention and Building Safety Commission; 675 IAC 22-2.3-158*)

**675 IAC 22-2.3-159 Section 1106.15.1; other areas**

Authority: IC 22-13-2-2

Affected: IC 22-12-7; IC 22-13; IC 22-14; IC 36-8-17

**Sec. 159.** Delete Section 1106.15.1 without substitution. (*Fire Prevention and Building Safety Commission; 675 IAC 22-2.3-159*)

**675 IAC 22-2.3-160 Section 1106.19.2; damaged hose**

Authority: IC 22-13-2-2

Affected: IC 22-12-7; IC 22-13; IC 22-14; IC 36-8-17

**Sec. 160.** Delete the last sentence of Section 1106.19.2 and substitute to read as follows: **Hoses removed from service shall not be used until repaired or rendered safe.** (*Fire Prevention and Building Safety Commission; 675 IAC 22-2.3-160*)

**675 IAC 22-2.3-161 Section 1201.2; permit required**

Authority: IC 22-13-2-2

Affected: IC 22-12-7; IC 22-13; IC 22-14; IC 36-8-17

**Sec. 161.** Delete Section 1201.2 without substitution. (*Fire Prevention and Building Safety Commission; 675 IAC 22-2.3-161*)

**675 IAC 22-2.3-162 Section 1204.2.1; ventilation**

Authority: IC 22-13-2-2

Affected: IC 22-12-7; IC 22-13; IC 22-14; IC 36-8-17

**Sec. 162.** Delete Section 1204.2.1 and substitute to read as follows: **Ventilation shall be in accordance with the Indiana Mechanical Code (675 IAC 18).** (*Fire Prevention and Building Safety Commission; 675 IAC 22-2.3-162*)

**675 IAC 22-2.3-163 Section 1205.1.5; equipment maintenance and housekeeping**

Authority: IC 22-13-2-2

Affected: IC 22-12-7; IC 22-13; IC 22-14; IC 36-8-17

**Sec. 163.** Change the first sentence of Section 1205.1.5 to read as follows: **Equipment shall be maintained and operated in accordance with the manufacturer’s instructions.** (*Fire Prevention and Building Safety Commission; 675 IAC 22-2.3-163*)

**675 IAC 22-2.3-164 Section 1206; spotting and pretreating**

Authority: IC 22-13-2-2

Affected: IC 22-12-7; IC 22-13; IC 22-14; IC 36-8-17

**Sec. 164.** Amend Section 1206 Spotting and pretreating as follows:

(1) Add new Section as follows:

**1206.2 Type I solvents.** The maximum quantity of Type I solvents permitted at any work station shall be one (1) gallon (4 L). Class I solvents shall be stored in approved safety cans or in sealed DOT-N approved metal shipping containers of not more than one (1) gallon (4 L) capacity. Dispensing shall be from approved cans.

(2) Amend Section 1206.2 as follows:

**1206.3 Type II and III solvents.** Scouring, brushing, and spotting and pretreating shall be conducted with Class II or III solvents. The maximum quantity of Type II or III solvents permitted at any work station shall be one (1) gallon (4 L). In other than a Group H-2 occupancy, the aggregate quantities of solvents shall not exceed the maximum allowable quantity per control area for use open.

(3) Renumber subsequent sections.

(*Fire Prevention and Building Safety Commission; 675 IAC 22-2.3-164*)

**675 IAC 22-2.3-165 Section 1301.2; permits**

Authority: IC 22-13-2-2

Affected: IC 22-12-7; IC 22-13; IC 22-14; IC 36-8-17

**Sec. 165.** Delete section 1301.2 without substitution. (*Fire Prevention and Building Safety Commission; 675 IAC 22-2.3-165*)

**675 IAC 22-2.3-166 Section 1414.1; where required**

Authority: IC 22-13-2-2

Affected: IC 22-12-7; IC 22-13; IC 22-14; IC 36-8-17

**Sec. 166.** Amend Section 1414.1 to read as follows: **1414.1 Where required. Structures under construction, alteration or demolition shall be provided with not less than one approved portable fire extinguishers in accordance with Section 905 and sized for not less than ordinary hazard as follows:**

(1) At each stairway on all floor levels where combustible materials have accumulated.

(2) In every storage and construction shed.

(3) Additional portable fire extinguishers shall be provided where special hazards exist, such as the storage and use of flammable and combustible liquids.

(*Fire Prevention and Building Safety Commission; 675 IAC 22-2.3-166*)

**675 IAC 22-2.3-167 Section 1416.3; fire extinguishers for roofing operations**

Authority: IC 22-13-2-2  
Affected: IC 22-12-7; IC 22-13; IC 22-14; IC 36-8-17

**Sec. 167.** In Section 1416.3, change the second sentence to read as follows: **There shall be not less than one multi-purpose portable fire extinguisher with a minimum 3-A 40-B:C rating on the roof being covered or repaired.** (*Fire Prevention and Building Safety Commission; 675 IAC 22-2.3-167*)

**675 IAC 22-2.3-168 Section 1501.2; permits**

Authority: IC 22-13-2-2  
Affected: IC 22-12-7; IC 22-13; IC 22-14; IC 36-8-17

**Sec. 168.** Delete Section 1501.2 without substitution. (*Fire Prevention and Building Safety Commission; 675 IAC 22-2.3-168*)

**675 IAC 22-2.3-169 Section 1504.1.2.5; clear space**

Authority: IC 22-13-2-2  
Affected: IC 22-12-7; IC 22-13; IC 22-14; IC 36-8-17

**Sec. 169.** In Exceptions 1 and 2 of Section 1504.1.2.5, delete “adequately” without substitution. (*Fire Prevention and Building Safety Commission; 675 IAC 22-2.3-169*)

**675 IAC 22-2.3-170 Section 1505.3.2; bottom drains**

Authority: IC 22-13-2-2  
Affected: IC 22-12-7; IC 22-13; IC 22-14; IC 36-8-17

**Sec. 170.** Add Exception 2 to Section 1505.3.2 to read as follows: **Exception 2. Bottom drains shall not be required for tanks that are equipped with automatic closing covers in accordance with Section 1505.7.** (*Fire Prevention and Building Safety Commission; 675 IAC 22-2.3-170*)

**675 IAC 22-2.3-171 Section 1505.8.1; location**

Authority: IC 22-13-2-2  
Affected: IC 22-12-7; IC 22-13; IC 22-14; IC 36-8-17

**Sec. 171.** Delete Section 1505.8.1 and substitute to read as follows: **Tanks shall be located an approved distance from furnaces and combustible floors and shall not be located on combustible floors.** (*Fire Prevention and Building Safety Commission; 675 IAC 22-2.3-171*)

**675 IAC 22-2.3-172 Section 1506.8 barriers**

Authority: IC 22-13-2-2  
Affected: IC 22-12-7; IC 22-13; IC 22-14; IC 36-8-17

**Sec. 172.** In Section 1506.8, delete “adequately grounded” and insert “grounded in an approved manner”. (*Fire Prevention and Building Safety Commission; 675 IAC 22-2.3-172*)

**675 IAC 22-2.3-173 Section 1601.2; permits**

Authority: IC 22-13-2-2  
Affected: IC 22-12-7; IC 22-13; IC 22-14; IC 36-8-17

**Sec. 173.** Delete Section 1601.2 without substitution. (*Fire Prevention and Building Safety Commission; 675 IAC 22-2.3-173*)

**675 IAC 22-2.3-174 Section 1701.2; permits**

Authority: IC 22-13-2-2  
Affected: IC 22-12-7; IC 22-13; IC 22-14; IC 36-8-17

**Sec. 174.** Delete Section 1701.2 without substitution. (*Fire Prevention and Building Safety Commission; 675 IAC 22-2.3-174*)

**675 IAC 22-2.3-175 Section 1703.3.1; warning signs**

Authority: IC 22-13-2-2  
Affected: IC 22-12-7; IC 22-13; IC 22-14; IC 36-8-17

**Sec. 175.** In the first sentence of Section 1703.3.1, delete the text after “premises”. (*Fire Prevention and Building Safety Commission; 675 IAC 22-2.3-175*)

**675 IAC 22-2.3-176 Section 1801.5; permits**

Authority: IC 22-13-2-2  
Affected: IC 22-12-7; IC 22-13; IC 22-14; IC 36-8-17

**Sec. 176.** Delete Section 1801.5 without substitution. (*Fire Prevention and Building Safety Commission; 675 IAC 22-2.3-176*)

**675 IAC 22-2.3-177 Section 1803.14.1; where required**

Authority: IC 22-13-2-2  
Affected: IC 22-12-7; IC 22-13; IC 22-14; IC 36-8-17

**Sec. 177.** Delete the second sentence of Section 1803.14.1, item 1 without substitution. (*Fire Prevention and Building Safety Commission; 675 IAC 22-2.3-177*)

**675 IAC 22-2.3-178 Table 1804.2.1; quantity limits for hazardous materials in a single fabrication area in group h-5<sup>a</sup>**

Authority: IC 22-13-2-2  
Affected: IC 22-12-7; IC 22-13; IC 22-14; IC 36-8-17

**Sec. 178.** Amend TABLE 1804.2.1 footnote (d) by deleting “Tables 2703.1.1(1) and 2704.14” and inserting “Table 2704.14”. (*Fire Prevention and Building Safety Commission; 675 IAC 22-2.3-178*)

**675 IAC 22-2.3-179 Table 1805.2.1; maximum quantities of hpm at a workstation<sup>e</sup>**

Authority: IC 22-13-2-2  
Affected: IC 22-12-7; IC 22-13; IC 22-14; IC 36-8-17

**Sec. 179.** Amend TABLE 1805.2.1 as follows: (1) In the MAXIMUM QUANTITY column, make the following changes:

- (A) For “Corrosive Liquid”, change to read “Use-open System 25 gallons<sup>am</sup>”.
- (B) For “Corrosive solid”, change to read “Use-closed System 150 gallons<sup>acf</sup>”.

## Proposed Rules

(2) Add a sentence to footnote “c” to read as follows: “When Note f also applies, the maximum increase allowed for both Notes c and f shall not exceed 100 percent.”

(3) Add footnote “f” to read: F. Quantities shall be allowed to be increased 100 percent for nonflammable, noncombustible corrosive liquids when the materials of construction for workstations are listed or approved for use without internatl fir extinguishing or suppression system protection. When Note c also applies, the maximum increase allowed for both Notes c and f shall not exceed 100 percent.

*(Fire Prevention and Building Safety Commission; 675 IAC 22-2.3-179)*

### **675 IAC 22-2.3-180 Section 1805.3.4.3; powered carts and trucks**

Authority: IC 22-13-2-2  
Affected: IC 22-12-7; IC 22-13; IC 22-14; IC 36-8-17

**Sec. 180.** In Section 1805.3.4.3, delete all text after “intended”. *(Fire Prevention and Building Safety Commission; 675 IAC 22-2.3-180)*

### **675 IAC 22-2.3-181 Section 1901.2; permit**

Authority: IC 22-13-2-2  
Affected: IC 22-12-7; IC 22-13; IC 22-14; IC 36-8-17

**Sec. 181.** Delete Section 1901.2 without substitution. *(Fire Prevention and Building Safety Commission; 675 IAC 22-2.3-181)*

### **675 IAC 22-2.3-182 Section 1903.5.2; static electricity and lightning protection**

Authority: IC 22-13-2-2  
Affected: IC 22-12-7; IC 22-13; IC 22-14; IC 36-8-17

**Sec. 182.** (a) Change the title of Section 1903.5.2 to read “Static electricity protection.”

(b) Delete the last sentence of Section 1903.5.2 without substitution. *(Fire Prevention and Building Safety Commission; 675 IAC 22-2.3-182)*

### **675 IAC 22-2.3-183 Section 1903.7; access plan**

Authority: IC 22-13-2-2  
Affected: IC 22-12-7; IC 22-13; IC 22-14; IC 36-8-17

**Sec. 183.** In Section 1903.7, delete all text after “submitted” and insert “to the code official”. *(Fire Prevention and Building Safety Commission; 675 IAC 22-2.3-183)*

### **675 IAC 22-2.3-184 Section 1906.2; cold decks**

Authority: IC 22-13-2-2  
Affected: IC 22-12-7; IC 22-13; IC 22-14; IC 36-8-17

**Sec. 184.** Delete the Exception in Section 1906.2. *(Fire Prevention and Building Safety Commission; 675 IAC 22-2.3-184)*

### **675 IAC 22-2.3-185 Section 1907.2; size of piles**

Authority: IC 22-13-2-2  
Affected: IC 22-12-7; IC 22-13; IC 22-14; IC 36-8-17

**Sec. 185.** Delete the Exception in Section 1907.2. *(Fire Prevention and Building Safety Commission; 675 IAC 22-2.3-185)*

### **675 IAC 22-2.3-186 Section 1908.3; size of piles**

Authority: IC 22-13-2-2  
Affected: IC 22-12-7; IC 22-13; IC 22-14; IC 36-8-17

**Sec. 186.** Delete the Exception in Section 1908.3. *(Fire Prevention and Building Safety Commission; 675 IAC 22-2.3-186)*

### **675 IAC 22-2.3-187 Section 1908.8; fire extinguishers**

Authority: IC 22-13-2-2  
Affected: IC 22-12-7; IC 22-13; IC 22-14; IC 36-8-17

**Sec. 187.** In Section 1908.8, delete “2-A:60 B:C” and insert “4-A:60B:C”. *(Fire Prevention and Building Safety Commission; 675 IAC 22-2.3-187)*

### **675 IAC 22-2.3-188 Section 2001.2; permits**

Authority: IC 22-13-2-2  
Affected: IC 22-12-7; IC 22-13; IC 22-14; IC 36-8-17

**Sec. 188.** Delete Section 2001.2 without substitution. *(Fire Prevention and Building Safety Commission; 675 IAC 22-2.3-188)*

### **675 IAC 22-2.3-189 Section 2006.5; kettle controls**

Authority: IC 22-13-2-2  
Affected: IC 22-12-7; IC 22-13; IC 22-14; IC 36-8-17

**Sec. 189.** Delete the last two (2) sentences of Section 2006.5 and substitute as follows: The thin-down tank shall have an approved vent. Thinning operations shall be provided with an approved vapor removal system. *(Fire Prevention and Building Safety Commission; 675 IAC 22-2.3-189)*

### **675 IAC 22-2.3-190 Section 2007.3; support**

Authority: IC 22-13-2-2  
Affected: IC 22-12-7; IC 22-13; IC 22-14; IC 36-8-17

**Sec. 190.** In the first sentence of Section 2007.3, delete “adequately” and insert after “physical damage”, “in an approved manner”. *(Fire Prevention and Building Safety Commission; 675 IAC 22-2.3-190)*

### **675 IAC 22-2.3-191 Section 2101.2; permits**

Authority: IC 22-13-2-2  
Affected: IC 22-12-7; IC 22-13; IC 22-14; IC 36-8-17

**Sec. 191.** Delete Section 2101.2 without substitution. *(Fire Prevention and Building Safety Commission; 675 IAC 22-2.3-191)*

### **675 IAC 22-2.3-192 Section 2103.2; exposure**

Authority: IC 22-13-2-2  
Affected: IC 22-12-7; IC 22-13; IC 22-14; IC 36-8-17

**Sec. 192.** Delete Section 2103.2 without substitution. *(Fire Prevention and Building Safety Commission; 675 IAC 22-2.3-192)*

### **675 IAC 22-2.3-193 Chapter 22; service stations and repair garages**

Authority: IC 22-13-2-2  
Affected: IC 22-12-7; IC 22-13; IC 22-14; IC 36-8-17

**Sec. 193. Change the title of Chapter 22 to read: MOTOR FUEL DISPENSING FACILITIES AND REPAIR GARAGES.** (*Fire Prevention and Building Safety Commission; 675 IAC 22-2.3-193*)

**675 IAC 22-2.3-194 Section 2201.1; scope**

Authority: IC 22-13-2-2

Affected: IC 22-12-7; IC 22-13; IC 22-14; IC 36-8-17

**Sec. 194. Amend Section 2201.1 to read:**

**2202.1 Scope.** Automotive motor fuel dispensing facilities, marine motor fuel dispensing facilities, fleet vehicle motor fuel dispensing facilities and repair garages shall be in accordance with this chapter and the Indiana Fuel Gas Code, Indiana Building Code and the Indiana Mechanical Code. Such operations shall include both public accessible and private operations.

When the term “service stations” is used, it shall mean “motor fuel dispensing facilities”.

(*Fire Prevention and Building Safety Commission; 675 IAC 22-2.3-194*)

**675 IAC 22-2.3-195 Section 2201.2; permits**

Authority: IC 22-13-2-2

Affected: IC 22-12-7; IC 22-13; IC 22-14; IC 36-8-17

**Sec. 195. Delete Section 2201.2** (*Fire Prevention and Building Safety Commission; 675 IAC 22-2.3-195*)

**675 IAC 22-2.3-196 Section 2201.3; construction documents**

Authority: IC 22-13-2-2

Affected: IC 22-12-7; IC 22-13; IC 22-14; IC 36-8-17

**Sec. 196. Change Section 2201.3 to read as follows: Plans and specifications shall be submitted in accordance with the General Administrative Rules (675 IAC 12-6).** (*Fire Prevention and Building Safety Commission; 675 IAC 22-2.3-196*)

**675 IAC 22-2.3-197 Section 2202.1; definitions**

Authority: IC 22-13-2-2

Affected: IC 22-12-7; IC 22-13; IC 22-14; IC 36-8-17

**Sec. 197. In Section 2202.1, amend the following definitions to read as follows:**

**AUTOMOTIVE SERVICE STATION** to read: **AUTOMOTIVE FUEL DISPENSING FACILITY.** That portion of property where flammable or combustible liquids or gases used as motor fuels are stored and dispensed from fixed equipment into the fuel tanks of motor vehicles or approved containers.

**FLEET VEHICLE SERVICE STATION** to read: **FLEET VEHICLE FUEL DISPENSING FACILITY.** That portion of a commercial, industrial, governmental or manufacturing property where liquids used as fuels are stored and dispensed into fuel tanks of motor vehicles that are used in connection with such businesses, by

persons within the employ of such businesses, or a commercial customer of such businesses.

**MARINE SERVICE STATION** to read: **MARINE FUEL DISPENSING FACILITY.**

**SELF-SERVICE STATION** to read: **SELF-SERVICE FUEL DISPENSING FACILITY.** That portion of a service station where liquid motor fuels are dispensed from fixed approved dispensing equipment into fuel tanks of motor vehicles or approved containers by persons other than a service station attendant.

(*Fire Prevention and Building Safety Commission; 675 IAC 22-2.3-197*)

**675 IAC 22-2.3-198 Section 2204.3.2; dispensers**

Authority: IC 22-13-2-2

Affected: IC 22-12-7; IC 22-13; IC 22-14; IC 36-8-17

**Sec. 198. Change Section Section 2204.3.2 Dispensers to read as follows: Dispensing devices shall comply with Section 2206.7. Dispensing devices operated by the insertion of coins or currency may be used provided change or credit can be issued.** (*Fire Prevention and Building Safety Commission; 675 IAC 22-2.3-198*)

**675 IAC 22-2.3-199 Section 2204.3.7; quantity limits**

Authority: IC 22-13-2-2

Affected: IC 22-12-7; IC 22-13; IC 22-14; IC 36-8-17

**Sec. 199. Change Section 2204.3.7 Quantity limits to read as follows: Dispensing equipment used at unsupervised locations shall comply with one (1) of the following:**

(1) Dispensing devices for Class I fuel shall be programmed or set to limit uninterrupted fuel delivery to 25 gallons (95 L) and require a manual action to resume delivery; or

(2) The amount of fuel being dispensed shall be limited in quantity by a preprogrammed card.

(*Fire Prevention and Building Safety Commission; 675 IAC 22-2.3-199*)

**675 IAC 22-2.3-200 Section 2204.4; dispensing into portable containers**

Authority: IC 22-13-2-2

Affected: IC 22-12-7; IC 22-13; IC 22-14; IC 36-8-17

**Sec. 200. Amend Section 2204.4 to read as follows: 2204.4 Dispensing into portable containers.** The dispensing of flammable or combustible liquids into portable approved containers shall comply with Section 2204.4.1 through Section 2204.4.3. (*Fire Prevention and Building Safety Commission; 675 IAC 22-2.3-200*)

**675 IAC 22-2.3-201 Section 2205.1.1; delivery vehicle location**

Authority: IC 22-13-2-2

Affected: IC 22-12-7; IC 22-13; IC 22-14; IC 36-8-17

**Sec. 201. Delete Section 2205.1.1 without substituting**

## Proposed Rules

tion. (Fire Prevention and Building Safety Commission; 675 IAC 22-2.3-201)

**675 IAC 22-2.3-202 Section 2205.1.2; tank capacity calculation**

Authority: IC 22-13-2-2  
Affected: IC 22-12-7; IC 22-13; IC 22-14; IC 36-8-17

Sec. 202. Change Section 2205.1.2 to read as follows: **2205.1.1 Tank capacity calculation.** The driver, operator or attendant of a tank vehicle shall, before making delivery to a tank, determine the unfilled, available capacity of such tank by a gauging device. (Fire Prevention and Building Safety Commission; 675 IAC 22-2.3-202)

**675 IAC 22-2.3-203 Section 2205.1.3; tank fill connections**

Authority: IC 22-13-2-2  
Affected: IC 22-12-7; IC 22-13; IC 22-14; IC 36-8-17

Sec. 203. Change Section 2205.1.3 to read as follows: **2205.1.2 Tank fill connections.** Delivery of flammable liquids to tanks more than 1,100 gallons in capacity shall be made by means of approved liquid - and vapor-tight connections between the delivery hose and tank fill pipe. Where tanks are equipped with any type of vapor recovery system, all connections required to be made for the safe and proper functioning of the particular vapor recovery process shall be made. Such connections shall be made liquid and vapor tight and remain connected throughout the unloading process. Vapors shall not be discharged at grade level during delivery. (Fire Prevention and Building Safety Commission; 675 IAC 22-2.3-203)

**675 IAC 22-2.3-204 Section 2205.2.2; emergency shutoff valves**

Authority: IC 22-13-2-2  
Affected: IC 22-12-7; IC 22-13; IC 22-14; IC 36-8-17

Sec. 204. Change Section 2205.2.2 to read as follows: **Automatic closing emergency shut-off valves required by Section 2206.7.4 shall be maintained in accordance with the manufacturer's instructions.** (Fire Prevention and Building Safety Commission; 675 IAC 22-2.3-204)

**675 IAC 22-2.3-205 Section 2206.2; method of storage**

Authority: IC 22-13-2-2  
Affected: IC 22-12-7; IC 22-13; IC 22-14; IC 36-8-17

Sec. 205. In Section 2206.2, delete "motor". (Fire Prevention and Building Safety Commission; 675 IAC 22-2.3-205)

**675 IAC 22-2.3-206 Section 2206.2.1; underground tanks**

Authority: IC 22-13-2-2  
Affected: IC 22-12-7; IC 22-13; IC 22-14; IC 36-8-17

Sec. 206. In Section 2206.2.1, delete "motor". (Fire Prevention and Building Safety Commission; 675 IAC 22-2.3-206)

**675 IAC 22-2.3-207 Section 2206.2.1.1; inventory control for underground tanks**

Authority: IC 22-13-2-2  
Affected: IC 22-12-7; IC 22-13; IC 22-14; IC 36-8-17

Sec. 207. Change Section 2206.2.1.1 Inventory control for underground tanks to read as follows: **Accurate daily inventory records shall be maintained and reconciled on underground fuel storage tanks for indication of possible leakage from tanks and piping. The records shall be kept at the premises or readily available for inspection by the code official upon written request and shall include records for each product showing daily reconciliation between sales, use, receipts and inventory on hand.** (Fire Prevention and Building Safety Commission; 675 IAC 22-2.3-207)

**675 IAC 22-2.3-208 Section 2206.2.2 aboveground tanks located inside buildings**

Authority: IC 22-13-2-2  
Affected: IC 22-12-7; IC 22-13; IC 22-14; IC 36-8-17

Sec. 208. In Section 2206.2.2, delete "motor". (Fire Prevention and Building Safety Commission; 675 IAC 22-2.3-208)

**675 IAC 22-2.3-209 TABLE 2206.2.3; minimum separation requirements for above-ground tanks**

Authority: IC 22-13-2-2  
Affected: IC 22-12-7; IC 22-13; IC 22-14; IC 36-8-17

Sec. 209. Change TABLE 2206.2.3 as follows:

(1) Add a listing to TABLE 2206.2.3 as follows:

Tank Type	Nearest Capacity	Nearest Building	Nearest Dispenser	Lot Line	Public Way	Between Tanks
Class III Liquids	Equal or less than					
ASTs	1,100	5	0 <sup>b</sup>	10	10	5

(2) Add Footnote <sup>b</sup> to read: <sup>b</sup> Class III Fuel Dispensers. (Fire Prevention and Building Safety Commission; 675 IAC 22-2.3-209)

**675 IAC 22-2.3-210 Section 2206.2.3; aboveground tanks located outside, above grade**

Authority: IC 22-13-2-2  
Affected: IC 22-12-7; IC 22-13; IC 22-14; IC 36-8-17

Sec. 210. Change Section 2206.2.3 as follows: **2206.2.3 Aboveground tanks located outside, above grade. Aboveground tanks shall not be used for the storage and dispensing of Class I, II IIIA liquid motor fuels except as provided by this section.**

(1) Class I, II or III-A liquids shall not be dispensed into the fuel tank of a motor vehicle from aboveground tanks at retail automotive service or self-service stations.

(2) Class I and II liquids shall not be dispensed into the fuel tanks of a motor vehicle from aboveground tanks at fleet vehicle service station except when such tanks are installed in accordance with the following:



**1. INSTALLATION OF TANKS**

Tanks shall be installed in accordance with Chapter 34 and shall be installed in special enclosures constructed in accordance with Section 2206.2.4 or in listed and approved tank enclosures or materials providing fire protection of not less than two (2) hours. The following additional criteria shall apply:

- (a) Guard posts or other means shall be provided to protect the area where tanks are installed. The design shall be in accordance with Section 312,
- (b) Each tank and each special enclosure shall be surrounded by a clear space of not less than three (3) feet to allow for maintenance and inspection,
- (c) Warning signs and identification signs shall be installed to clearly identify hazards. The design shall be in accordance with Sections 2205.6, 2209.5.7 and 3404.2.3. Conspicuous signs prohibiting simultaneous tank filling and fuel dispensing shall be posted,
- (d) Tanks containing motor fuels shall not exceed a ten thousand (10,000) gallon individual or eighteen thousand (18,000) gallon aggregate capacity. Installations having the maximum allowable aggregate capacity shall be separated from other such installations by not less than one hundred (100) feet, and
- (e) Tanks shall be provided with automatic fuel shut-off devices capable of stopping the delivery of fuel when the level in the tank reaches ninety percent (90%) of tank capacity.

**EXCEPTIONS:** 1. Aboveground storage tanks for motor vehicle fuel-dispensing stations legally installed according to the code in effect at the time of installation and in operation prior to September 7, 1992.

2. Single tank installations where the fuel tank has a capacity of one thousand one hundred (1,100) gallons or less that are in compliance with Chapter 34 of this code.

3. Diesel tanks and dispensing operations when all the following criteria are met:

- A. The distance in feet from any property line when not adjacent to a public way shall be double the distance specified in Table 2206.2.3.
- B. The distance in feet from a property line adjacent to a public way, to include the opposite sides of a public way, shall be double the distance specified in Table 2206.2.3.
- C. The distance in feet from adjacent structures shall be double the distance specified in Table 2206.2.3.
- D. In compliance with Chapter 34 of this code.
- E. The diesel tank shall be double the distance specified in Table 2206.2.3 for the property line including the opposite side of the public way from any non-diesel fuel tank or dispensing operation.

**2. INSTALLATION OF DISPENSING SYSTEMS**

Dispensing systems shall be installed in accordance with Chapters 22 and 34 except as follows:

- (a) Motor fuels shall be transferred from tanks by means of fixed pumps which are designed and equipped

to allow control of the flow and to prevent leakage or accidental discharge,

- (b) Tank and tank enclosure openings shall be through the top only. Approved antisiphon devices shall be installed at each connection of piping to a tank when such piping extends below the level of the top of such tank, and
- (c) Dispensing devices are allowed to be installed on top of special enclosures.

**3. PLANS**

Plans submitted under 675 IAC 12-6, Design Releases, shall include the method of storage and dispensing, quantities and types of liquids to be stored, distances from tanks and dispensers to property lines and buildings, vehicle access, fire appliances, collision barriers, design and construction of tanks and tank supports, secondary containment tank venting, vapor recovery provisions, and emergency controls.

**4. MAINTENANCE**

Tanks, special enclosures, and dispensing systems shall be maintained in proper condition. Damage shall be repaired immediately using materials having equal or greater strength and fire resistance.

*(Fire Prevention and Building Safety Commission; 675 IAC 22-2.3-210)*

**675 IAC 22-2.3-211 Section 2206.2.3.1; storage tanks at bulk plants**

Authority: IC 22-13-2-2

Affected: IC 22-12-7; IC 22-13; IC 22-14; IC 36-8-17

Sec. 211. Add Section 2206.2.3.1 as follows: **2206.2.3.1 Storage Tanks at Bulk Plants.** Above ground tanks serving as bulk storage tanks, shall not be used for fueling operations. *(Fire Prevention and Building Safety Commission; 675 IAC 22-2.3-211)*

**675 IAC 22-2.3-212 Section 2206.5; secondary containment**

Authority: IC 22-13-2-2

Affected: IC 22-12-7; IC 22-13; IC 22-14; IC 36-8-17

Sec. 212. Change Section 2206.5 as follows:

- (1) In the first paragraph, change "Chapter 34" to "Section 3404.2.10".
- (2) Add an EXCEPTION to read as follows:

**EXCEPTION:** Approved aboveground tanks with a capacity of five hundred (500) gallons or less, utilized solely for the storage of used motor oil, and in compliance with EPA 40 CFR 279.22 and EPA 40 CFR 264.175 are exempt from the requirements of Section 3404.2.10.

*(Fire Prevention and Building Safety Commission; 675 IAC 22-2.3-212)*

**675 IAC 22-2.3-213 Section 2206.6.2.6; spill containers**

Authority: IC 22-13-2-2

Affected: IC 22-12-7; IC 22-13; IC 22-14; IC 36-8-17

Sec. 213. Change section 2206.6.2.6 to read as follows: A

## Proposed Rules

spill container having a capacity of not less than 5 gallons (19 L) shall be provided for liquid and vapor tight fill connections. For tanks with a top fill connection, spill containers shall be noncombustible and shall be fixed to the tank and equipped with a manual drain valve that drains into the primary tank. For tanks with a remote fill connection, a portable spill container is allowed. *(Fire Prevention and Building Safety Commission; 675 IAC 22-2.3-213)*

### 675 IAC 22-2.3-214 Section 2206.7.4; dispenser emergency valve

Authority: IC 22-13-2-2  
Affected: IC 22-12-7; IC 22-13; IC 22-14; IC 36-8-17

Sec. 214. Change the last sentence of Section 2206.7.4 to read as follows: Emergency shut-off valves shall be installed and maintained in accordance with the manufacturer's instructions and tested at the time of initial installation. *(Fire Prevention and Building Safety Commission; 675 IAC 22-2.3-214)*

### 675 IAC 22-2.3-215 Section 2206.7.6.1; special requirements for nozzles

Authority: IC 22-13-2-2  
Affected: IC 22-12-7; IC 22-13; IC 22-14; IC 36-8-17

Sec. 215. Change Section 2206.7.6.1 as follows: Delete Item 2 entirely and renumber Items 3 and 4 accordingly. *(Fire Prevention and Building Safety Commission; 675 IAC 22-2.3-215)*

### 675 IAC 22-2.3-216 Section 2206.7.9.1.3; piping

Authority: IC 22-13-2-2  
Affected: IC 22-12-7; IC 22-13; IC 22-14; IC 36-8-17

Sec. 216. Change the last sentence of Section 2206.7.9.1.3 to read as follows: Condensate tanks shall be designed and installed in accordance with the manufacturer's recommendation. *(Fire Prevention and Building Safety Commission; 675 IAC 22-2.3-216)*

### 675 IAC 22-2.3-217 Section 2301.2; permits

Authority: IC 22-13-2-2  
Affected: IC 22-12-7; IC 22-13; IC 22-14; IC 36-8-17

Sec. 217. Delete Section 2301.2 without substitution. *(Fire Prevention and Building Safety Commission; 675 IAC 22-2.3-217)*

### 675 IAC 22-2.3-218 Section 2301.3; construction documents

Authority: IC 22-13-2-2  
Affected: IC 22-12-7; IC 22-13; IC 22-14; IC 36-8-17

Sec. 218. Amend Section 2301.3 by deleting the first three (3) sentences and substitute to read as follows: Plans and specifications including the information specified in Section 2301.3 shall be submitted to the fire department having jurisdiction. A copy of the plans shall be maintained on the

premises. *(Fire Prevention and Building Safety Commission; 675 IAC 22-2.3-218)*

### 675 IAC 22-2.3-219 Section 2301.4; evacuation plan

Authority: IC 22-13-2-2  
Affected: IC 22-12-7; IC 22-13; IC 22-14; IC 36-8-17

Sec. 219. Delete Section 2301.4 and substitute to read as follows: An evacuation plan for public accessible areas and a separate set of plans indicating location and width of aisles, location of exits and exit signs, height of storage, and locations of hazardous materials shall be submitted to the fire department having jurisdiction for review. Following review of the plans, a copy of the plans shall be maintained on the premises in an approved location. *(Fire Prevention and Building Safety Commission; 675 IAC 22-2.3-219)*

### 675 IAC 22-2.3-220 Section 2304.2; designation based on engineering analysis

Authority: IC 22-13-2-2  
Affected: IC 22-12-7; IC 22-13; IC 22-14; IC 36-8-17

Sec. 220. In Section 2304.2, delete "NFPA 231 and NFPA 231C" and insert "NFPA 13 (675 IAC 13-1-8)". *(Fire Prevention and Building Safety Commission; 675 IAC 22-2.3-220)*

### 675 IAC 22-2.3-221 TABLE 2306.2; GENERAL FIRE PROTECTION AND LIFE SAFETY REQUIREMENTS

Authority: IC 22-13-2-2  
Affected: IC 22-12-7; IC 22-13; IC 22-14; IC 36-8-17

Sec. 221. Change TABLE 2306.2 by deleting "when required by the code official" from Footnote d and g. *(Fire Prevention and Building Safety Commission; 675 IAC 22-2.3-221)*

### 675 IAC 22-2.3-222 Section 2306.6.1; access doors

Authority: IC 22-13-2-2  
Affected: IC 22-12-7; IC 22-13; IC 22-14; IC 36-8-17

Sec. 222. In Section 2306.6.1, add to the last sentence "and shall have landings in accordance with the Indiana Building Code (675 IAC 13) Section 1003.3.1.4." *(Fire Protection and Building Safety Commission; 675 IAC 22-2.3-222)*

### 675 IAC 22-2.3-223 Section 2306.6.1.1; number of doors required

Authority: IC 22-13-2-2  
Affected: IC 22-12-7; IC 22-13; IC 22-14; IC 36-8-17

Sec. 223. Add Exception to Section 2306.6.1.1 to read: In buildings having ESFR sprinkler systems, a minimum of one (1) access door shall be provided in each 200 lineal feet (60,560 mm), or fraction thereof, of the exterior walls which face the required fire apparatus access road. Spacing between doors shall not exceed 200 lineal feet. *(Fire Prevention and Building Safety Commission; 675 IAC 22-2.3-223)*

**675 IAC 22-2.3-224 Section 2306.9; aisles**

Authority: IC 22-13-2-2  
Affected: IC 22-12-7; IC 22-13; IC 22-14; IC 36-8-17

**Sec. 224.** In Section 2306.9, delete “NFPA 231, NFPA 231C” and insert “NFPA 13 (675 IAC 13-1-8)”. (*Fire Prevention and Building Safety Commission; 675 IAC 22-2.3-224*)

**675 IAC 22-2.3-225 Section 2307.2.1; shelf storage**

Authority: IC 22-13-2-2  
Affected: IC 22-12-7; IC 22-13; IC 22-14; IC 36-8-17

**Sec. 225.** In Section 2307.2.1, delete “NFPA 231” and insert “NFPA 13 (675 IAC 13-1-8)”. (*Fire Prevention and Building Safety Commission; 675 IAC 22-2.3-225*)

**675 IAC 22-2.3-226 Section 2308.2.2(2), Section 2308.2.2.1; racks with solid shelving and fire protection**

Authority: IC 22-13-2-2  
Affected: IC 22-12-7; IC 22-13; IC 22-14; IC 36-8-17

**Sec. 226.** In Section 2308.2.2(2) and Section 2308.2.2.1, delete “NFPA 231C” and insert “NFPA 13 (675 IAC 13-1-8)”. (*Fire Prevention and Building Safety Commission; 675 IAC 22-2.3-226*)

**675 IAC 22-2.3-227 Section 2308.4; column protection**

Authority: IC 22-13-2-2  
Affected: IC 22-12-7; IC 22-13; IC 22-14; IC 36-8-17

**Sec. 227.** In Section 2308.4, delete “NFPA 231C” and insert “NFPA 13 (675 IAC 13-1-8)”. (*Fire Prevention and Building Safety Commission; 675 IAC 22-2.3-227*)

**675 IAC 22-2.3-228 Section 2310.1; general**

Authority: IC 22-13-2-2  
Affected: IC 22-12-7; IC 22-13; IC 22-14; IC 36-8-17

**Sec. 228.** In Section 2310.1, delete “NFPA 231C” and insert “NFPA 13 (675 IAC 13-1-8)”. (*Fire Prevention and Building Safety Commission; 675 IAC 22-2.3-228*)

**675 IAC 22-2.3-229 Section 2401.2; approval required**

Authority: IC 22-13-2-2  
Affected: IC 22-12-7; IC 22-13; IC 22-14; IC 36-8-17

**Sec. 229.** Delete Section 2401.2. (*Fire Prevention and Building Safety Commission; 675 IAC 22-2.3-229*)

**675 IAC 22-2.3-230 Section 2401.4; permits**

Authority: IC 22-13-2-2  
Affected: IC 22-12-7; IC 22-13; IC 22-14; IC 36-8-17

**Sec. 230.** Delete Section 2401.4. (*Fire Prevention and Building Safety Commission; 675 IAC 22-2.3-230*)

**675 IAC 22-2.3-231 Section 2401.5; use period**

Authority: IC 22-13-2-2  
Affected: IC 22-12-7; IC 22-13; IC 22-14; IC 36-8-17

**Sec. 231.** In Section 2401.5, delete “180” and insert “30”. (*Fire Prevention and Building Safety Commission; 675 IAC 22-2.3-231*)

**675 IAC 22-2.3-232 Section 2401.6; construction documents**

Authority: IC 22-13-2-2  
Affected: IC 22-12-7; IC 22-13; IC 22-14; IC 36-8-17

**Sec. 232.** In Section 2401.6, delete “with each application for approval” and substitute “to the fire department having jurisdiction”. (*Fire Prevention and Building Safety Commission; 675 IAC 22-2.3-232*)

**675 IAC 22-2.3-233 Section 2401.7.1; inspection report**

Authority: IC 22-13-2-2  
Affected: IC 22-12-7; IC 22-13; IC 22-14; IC 36-8-17

**Sec. 233.** Delete Section 2401.7.1 in its entirety and substitute to read as follows: An inspection report shall be made available to the fire department having jurisdiction and shall consist of maintenance anchors and fabric inspections. (*Fire Prevention and Building Safety Commission; 675 IAC 22-2.3-233*)

**675 IAC 22-2.3-234 Section 2406.1; flame-resistant treatment**

Authority: IC 22-13-2-2  
Affected: IC 22-12-7; IC 22-13; IC 22-14; IC 36-8-17

**Sec. 234.** In Section 2406.1, change as follows:

- (1) Delete “before a permit is granted”.
- (2) Delete “by the permit”.

(*Fire Prevention and Building Safety Commission; 675 IAC 22-2.3-234*)

**675 IAC 22-2.3-235 Section 2407.2; fire protection equipment**

Authority: IC 22-13-2-2  
Affected: IC 22-12-7; IC 22-13; IC 22-14; IC 36-8-17

**Sec. 235.** Delete Section 2407.2 without substitution. (*Fire Prevention and Building Safety Commission; 675 IAC 22-2.3-235*)

**675 IAC 22-2.3-236 Section 2410.5.1; arrangement and maintenance**

Authority: IC 22-13-2-2  
Affected: IC 22-12-7; IC 22-13; IC 22-14; IC 36-8-17

**Sec. 236.** Delete the text of Section 2410.5.1 and substitute to read as follows: A plan indicating the exit ways, aisles and seating shall be submitted to the fire department having jurisdiction and a copy shall be maintained on the premises. Aisles shall be maintained clear at all times during occupancy. (*Fire Prevention and Building Safety Commission; 675 IAC 22-2.3-236*)

**675 IAC 22-2.3-237 Section 2411.1; installation**

Authority: IC 22-13-2-2  
Affected: IC 22-12-7; IC 22-13; IC 22-14; IC 36-8-17

## Proposed Rules

**Sec. 237.** In Section 2411.1, delete “and shall be approved by the code official” and substitute “in effect at the time the equipment is installed”. (*Fire Prevention and Building Safety Commission; 675 IAC 22-2.3-237*)

**675 IAC 22-2.3-238** Section 2411.2; venting  
Authority: IC 22-13-2-2  
Affected: IC 22-12-7; IC 22-13; IC 22-14; IC 36-8-17

**Sec. 238.** Change Section 2411.2 as follows:

(1) At the end of the sentence, add “, in effect at the time the equipment is installed”.

(2) Delete “when required” from the second sentence and substitute “having openings not exceeding ¼ inch (66 mm) wire mesh.”

(*Fire Prevention and Building Safety Commission; 675 IAC 22-2.3-238*)

**675 IAC 22-2.3-239** Section 2501.2; permit required  
Authority: IC 22-13-2-2  
Affected: IC 22-12-7; IC 22-13; IC 22-14; IC 36-8-17

**Sec. 239.** Delete Section 2501.2. (*Fire Prevention and Building Safety Commission; 675 IAC 22-2.3-239*)

**675 IAC 22-2.3-240** Section 2504.5; fire safety plan  
Authority: IC 22-13-2-2  
Affected: IC 22-12-7; IC 22-13; IC 22-14; IC 36-8-17

**Sec. 240.** In the first sentence of Section 2504.5, delete “and approval”. (*Fire Prevention and Building Safety Commission; 675 IAC 22-2.3-240*)

**675 IAC 22-2.3-241** Section 2601.2; permits  
Authority: IC 22-13-2-2  
Affected: IC 22-12-7; IC 22-13; IC 22-14; IC 36-8-17

**Sec. 241.** Delete Section 2601.2 without substitution. (*Fire Prevention and Building Safety Commission; 675 IAC 22-2.3-241*)

**675 IAC 22-2.3-242** Section 2601.3; restricted area  
Authority: IC 22-13-2-2  
Affected: IC 22-12-7; IC 22-13; IC 22-14; IC 36-8-17

**Sec. 242.** Change Section 2601.3 as follows:

(1) Delete “unless approval has been obtained from the code official”.

(2) Delete “4” and “5” without substitution.

(*Fire Prevention and Building Safety Commission; 675 IAC 22-2.3-242*)

**675 IAC 22-2.3-243** Section 2602.1; definitions  
Authority: IC 22-13-2-2  
Affected: IC 22-12-7; IC 22-13; IC 22-14; IC 36-8-17

**Sec. 243.** In Definitions, Section 2602.1, change the definition of HOTWORKS PERMITS by deleting “and prepermitted by the code official”. (*Fire Prevention and Building Safety Commission; 675 IAC 22-2.3-243*)

**675 IAC 22-2.3-244** Section 2604.1.8; sprinkler protection  
Authority: IC 22-13-2-2  
Affected: IC 22-12-7; IC 22-13; IC 22-14; IC 36-8-17

**Sec. 244.** Change the last sentence of Section 2604.1.8 to read: The code official shall be notified where the sprinkler protection is impaired. (*Fire Prevention and Building Safety Commission; 675 IAC 22-2.3-244*)

**675 IAC 22-2.3-245** Section 2604.1.9; fire detection systems  
Authority: IC 22-13-2-2  
Affected: IC 22-12-7; IC 22-13; IC 22-14; IC 36-8-17

**Sec. 245.** In Section 2604.1.9, delete “approved”. (*Fire Prevention and Building Safety Commission; 675 IAC 22-2.3-245*)

**675 IAC 22-2.3-246** Section 2701.1; scope  
Authority: IC 22-13-2-2  
Affected: IC 22-12-7; IC 22-13; IC 22-14; IC 36-8-17

**Sec. 246.** In Section 2701.1 Scope, add Exception 10 to read as follows: 10. Laboratory use of hazardous chemicals provided a Chemical Hygiene Plan as defined in Section 2702 of the code has been implemented at the facility. (*Fire Prevention and Building Safety Commission; 675 IAC 22-2.3-246*)

**675 IAC 22-2.3-247** Section 2701.2.1; mixtures  
Authority: IC 22-13-2-2  
Affected: IC 22-12-7; IC 22-13; IC 22-14; IC 36-8-17

**Sec. 247.** In Section 2701.2.1, delete everything after “reference standards;” and substitute “by a recognized organization, or material safety data sheet (MSDS)”. (*Fire Prevention and Building Safety Commission; 675 IAC 22-2.3-247*)

**675 IAC 22-2.3-248** Section 2701.4; permits  
Authority: IC 22-13-2-2  
Affected: IC 22-12-7; IC 22-13; IC 22-14; IC 36-8-17

**Sec. 248.** Delete Section 2701.4 without substitution. (*Fire Prevention and Building Safety Commission; 675 IAC 22-2.3-248*)

**675 IAC 22-2.3-249** Section 2701.4.1; hazardous materials management plan  
Authority: IC 22-13-2-2  
Affected: IC 22-12-7; IC 22-13; IC 22-14; IC 36-8-17

**Sec. 249.** Change Section 2701.4.1 to read as follows: Hazardous materials management plan. Regulation by the Emergency Planning and Community Right to Know Act (EPCRA) constitutes compliance with Section 2701.4.1.

For hazardous materials used, stored dispensed, or handled in excess of quantities listed in TABLES 2703.1.1, an owner or operator of a facility not regulated by the Federal Emergency Planning and Community Right to Know Act shall notify the servicing fire depart-

ment in writing and shall, when asked, allow the fire department to conduct an on-site health hazardous materials inspection of the facility and to provide the fire department specific location information on those hazardous materials.

*(Fire Prevention and Building Safety Commission; 675 IAC 22-2.3-249)*

**675 IAC 22-2.3-250 Section 2701.4.2; hazardous materials inventory statement**

Authority: IC 22-13-2-2  
Affected: IC 22-12-7; IC 22-13; IC 22-14; IC 36-8-17

**Sec. 250.** Change Section 2701.4.2 to read as follows: **Hazardous materials management plan.** This section does not apply to facilities regulated under the Emergency Planning and Community Right to Know Act (EPCRA) as set forth at 42 U.S.C. 11001, et seq.

For hazardous materials used, stored, dispensed, or handled in excess of the quantities listed in TABLES 2703.1.1, an owner or operator of a facility not regulated by the Federal Emergency Planning and Community Right to Know Act shall notify the servicing fire department in writing and shall, when asked, allow the fire department to conduct an on-site health hazardous materials inspection of the facility and provide to the fire department specific location information on those hazardous materials.

*(Fire Prevention and Building Safety Commission; 675 IAC 22-2.3-250)*

**675 IAC 22-2.3-251 Section 2701.5.1; temporarily out of service facilities**

Authority: IC 22-13-2-2  
Affected: IC 22-12-7; IC 22-13; IC 22-14; IC 36-8-17

**Sec. 251.** In Section 2701.5.1, delete “maintain a permit and”. *(Fire Prevention and Building Safety Commission; 675 IAC 22-2.3-251)*

**675 IAC 22-2.3-252 Section 2701.5.2; permanently out of service facilities**

Authority: IC 22-13-2-2  
Affected: IC 22-12-7; IC 22-13; IC 22-14; IC 36-8-17

**Sec. 252.** In Section 2701.5.2, change the following:  
(1) Delete “permit” and substitute “hazardous materials management plan”.

(2) Delete “an approved manner” and substitute “accordance with Section 2701.5.3”.

(3) Delete the second and third sentences.

*(Fire Prevention and Building Safety Commission; 675 IAC 22-2.3-252)*

**675 IAC 22-2.3-253 Section 2701.5.3; facility closure plan**

Authority: IC 22-13-2-2  
Affected: IC 22-12-7; IC 22-13; IC 22-14; IC 36-8-17

**Sec. 253.** Change Section 2701.5.3 to read as follows: **Facility closure plan.** The owner or operator shall submit a plan to the servicing fire department to terminate storage, dispensing, handling or use of hazardous materials at least 30 days prior to facility closure. The plan shall demonstrate that hazardous materials which were stored, dispensed, handled or used in the facility have been transported, disposed of or reused in a manner that eliminates the need for further maintenance and any threat to public health and safety. *(Fire Prevention and Building Safety Commission; 675 IAC 22-2.3-253)*

**675 IAC 22-2.3-254 Section 2702.1; definitions**

Authority: IC 22-13-2-2  
Affected: IC 22-12-7; IC 22-13; IC 22-14; IC 36-8-17

**Sec. 254.** Add the following definitions to Section 2702.1: **CHEMICAL HYGIENE PLAN** means a written program developed and implemented at the facility which sets forth procedures, equipment, personal protective equipment and work practices that are capable of protecting individuals from the health hazards and other hazards presented by hazardous chemicals used at that particular facility.

**LABORATORY** means a facility where the “laboratory use of hazardous chemicals” occurs. It is a facility where relatively small quantities of hazardous chemicals are used on a non-production basis.

**LABORATORY SCALE** means work with substances in which the containers used for reactions, transfers, and other handling of substances are manipulated by one person. “Laboratory scale” excludes those facilities whose function is to produce commercial quantities of materials. **LABORATORY USE OF HAZARDOUS CHEMICALS** means handling or use of such chemicals in which all of the following conditions are met:

- (1) chemical manipulations are carried out on a “laboratory scale”;
- (2) multiple chemical procedures or chemicals are used;
- (3) the procedures involved are not part of a production process; and
- (4) laboratory practices and equipment are available and in common use to minimize the potential for employee exposure and to other risks from hazardous chemicals.

*(Fire Prevention and Building Safety Commission; 675 IAC 22-2.3-254)*

**675 IAC 22-2.3-255 Section 2703.2.6.1.1; return to service**

Authority: IC 22-13-2-2  
Affected: IC 22-12-7; IC 22-13; IC 22-14; IC 36-8-17

**Sec. 255.** In Section 2703.2.6.1.1, delete “be tested in an approved manner” and substitute “not be defective and shall be compatible with the liquid to be stored”. *(Fire Prevention and Building Safety Commission; 675 IAC 22-2.3-255)*

## Proposed Rules

### 675 IAC 22-2.3-256 Section 2703.3; release of hazardous materials

Authority: IC 22-13-2-2

Affected: IC 22-12-7; IC 22-13; IC 22-14; IC 36-8-17

Sec. 256. Change Section 2703.3 to read as follows: Hazardous substances shall not be intentionally released that create a risk of a fire or explosion into a sewer, storm drain, ditch, drainage canal, lake, river, tidal waterway, upon the ground, sidewalk, street, highway, or into the atmosphere.

**EXCEPTIONS:** 1. Unless release is not prohibited by local, state or federal law; or

2. Release is of a material or quantity that is unregulated. (*Fire Prevention and Building Safety Commission; 675 IAC 22-2.3-256*)

### 675 IAC 22-2.3-257 Section 2703.3.1; unauthorized discharge

Authority: IC 22-13-2-2

Affected: IC 22-12-7; IC 22-13; IC 22-14; IC 36-8-17

Sec. 257. Change Section 2703.3.1 to read as follows: Any unplanned sudden or non-sudden release into the environment of a listed hazardous substance that exceeds in any 24-hour period the reportable quantity for that substance, as identified in TABLE 302.4 of 40 CFR 302 and 40 CFR 355 Appendix A (July 1, 1997), and either causes a fire and/or explosion hazard, such as one that threatens contiguous property or the general public, or causes an injury requiring emergency medical treatment must be immediately reported to the servicing fire department. (*Fire Prevention and Building Safety Commission; 675 IAC 22-2.3-257*)

### 675 IAC 22-2.3-258 Section 2703.3.1.1; records

Authority: IC 22-13-2-2

Affected: IC 22-12-7; IC 22-13; IC 22-14; IC 36-8-17

Sec. 258. Change Section 2703.3.1.1 to read as follows: Records shall be provided of the unauthorized discharge of hazardous materials by the owner or the operator. (*Fire Prevention and Building Safety Commission; 675 IAC 22-2.3-258*)

### 675 IAC 22-2.3-259 Section 2703.3.1.4; responsibility for cleanup

Authority: IC 22-13-2-2

Affected: IC 22-12-7; IC 22-13; IC 22-14; IC 36-8-17

Sec. 259. Change the title and text of Section 2703.3.1.4 to read as follows: 2703.1.4 Responsibility for control and mitigation. The person, firm, or corporation responsible for an unplanned sudden or non-sudden release shall institute and complete all actions necessary to remedy the effects of such unplanned release at no cost to the servicing fire department. Control and mitigation may be initiated by the fire department or by an authorized individual or firm. Cost associated with such control or mitigation shall be

borne by the owner, operator, or other person responsible for the release. (*Fire Prevention and Building Safety Commission; 675 IAC 22-2.3-259*)

### 675 IAC 22-2.3-260 Section 2703.4; material safety data sheets

Authority: IC 22-13-2-2

Affected: IC 22-12-7; IC 22-13; IC 22-14; IC 36-8-17

Sec. 260. Delete Section 2703.4 and substitute to read as follows: 2703.4 Material Safety Data Sheets (MSDS) for applicable hazardous materials shall be kept in a location which is acceptable to both the facility operator and the servicing fire department. (*Fire Prevention and Building Safety Commission; 675 IAC 22-2.3-260*)

### 675 IAC 22-2.3-261 Section 2703.9.9; shelf storage

Authority: IC 22-13-2-2

Affected: IC 22-12-7; IC 22-13; IC 22-14; IC 36-8-17

Sec. 261. Change Section 2703.9.9 to read as follows: 2703.9.9 Shelf storage. Shelving shall be of substantial construction, adequately braced and anchored. For seismic requirements and the seismic zone in which the material is located, see the building code. Shelf storage of hazardous materials shall be maintained in an orderly manner. (*Fire Prevention and Building Safety Commission; 675 IAC 22-2.3-261*)

### 675 IAC 22-2.3-262 Table E 2703.11.1; maximum allowable quantity per indoor and outdoor control area in Groups M and S occupancies, nonflammable solids, nonflammable and noncombustible liquids

Authority: IC 22-13-2-2

Affected: IC 22-12-7; IC 22-13; IC 22-14; IC 36-8-17

Sec. 262. Amend Table 2703.11.1 as follows:

(1) Change the "Solids (pounds)" column to read "Solids pounds".

(2) Change the "Liquids gallons (pounds)" column to read "Liquid gallons".

(*Fire Prevention and Building Safety Commission; 675 IAC 22-2.3-262*)

### 675 IAC 22-2.3-263 Section 2704.10; supervision

Authority: IC 22-13-2-2

Affected: IC 22-12-7; IC 22-13; IC 22-14; IC 36-8-17

Sec. 263. In Section 2704.10 Supervision, add an EXCEPTION to read: EXCEPTION: A facility that is provided with a watchman service and is provided with an audible fire alarm system that can be heard by the watchman in all areas of the facility. (*Fire Prevention and Building Safety Commission; 675 IAC 22-2.3-263*)

### 675 IAC 22-2.3-264 Section 2801.2; permits

Authority: IC 22-13-2-2

Affected: IC 22-12-7; IC 22-13; IC 22-14; IC 36-8-17

**Sec. 264. Delete Section 2801.2 without substitution.** (*Fire Prevention and Building Safety Commission; 675 IAC 22-2.3-264*)

**675 IAC 22-2.3-265 Section 2801.3; material safety data sheets**

Authority: IC 22-13-2-2  
Affected: IC 22-12-7; IC 22-13; IC 22-14; IC 36-8-17

**Sec. 265. In Section 2801.3, delete “at an approved location”.** (*Fire Prevention and Building Safety Commission; 675 IAC 22-2.3-265*)

**675 IAC 22-2.3-266 Section 2901.1; scope**

Authority: IC 22-13-2-2  
Affected: IC 22-12-7; IC 22-13; IC 22-14; IC 36-8-17

**Sec. 266. Amend Section 2901.1 Scope by deleting the second sentence.** (*Fire Prevention and Building Safety Commission; 675 IAC 22-2.3-266*)

**675 IAC 22-2.3-267 Section 2901.3; permits**

Authority: IC 22-13-2-2  
Affected: IC 22-12-7; IC 22-13; IC 22-14; IC 36-8-17

**Sec. 267. Delete Section 2901.3 without substitution.** (*Fire Prevention and Building Safety Commission; 675 IAC 22-2.3-267*)

**675 IAC 22-2.3-268 Section 2902.1; definition**

Authority: IC 22-13-2-2  
Affected: IC 22-12-7; IC 22-13; IC 22-14; IC 36-8-17

**Sec. 268. In Section 2902.1, add “, certain synthetic fibers” after “wastepaper”.** (*Fire Prevention and Building Safety Commission; 675 IAC 22-2.3-268*)

**675 IAC 22-2.3-269 Section 2903.4; agricultural products**

Authority: IC 22-13-2-2  
Affected: IC 22-12-7; IC 22-13; IC 22-14; IC 36-8-17

**Sec. 269. Change Section 2903.4 to read as follows: 2903.4 Agricultural products and combustible fibers. Combustible fibers, hay, straw, or similar agricultural products shall not be stored adjacent to structures or combustible materials unless a clear horizontal distance equal to the height of a pile is maintained between such storage and structures or combustible materials. Storage shall be limited to stacks of 100 tons (91 metric tons) each. Stacks shall be separated by a minimum of 20 feet (6,096 mm) of clear space. Exterior storage of agricultural products and combustible fibers shall be surrounded with an approved fence. Fences shall be a minimum of 6 feet (1,829 mm) in height. Quantities of hay, straw and other agricultural products shall not be limited or fencing required when stored in or near farm structures located outside closely built areas. A permit shall not be required for agricultural storage.** (*Fire Prevention and Building Safety Commission; 675 IAC 22-2.3-269*)

**675 IAC 22-2.3-270 Section 2904.3; storage of 100 cubic feet to 500 cubic feet**

Authority: IC 22-13-2-2  
Affected: IC 22-12-7; IC 22-13; IC 22-14; IC 36-8-17

**Sec. 270. In Section 2904.3, change “approved” to “listed”.** (*Fire Prevention and Building Safety Commission; 675 IAC 22-2.3-270*)

**675 IAC 22-2.3-271 Section 2904.4; storage of more than 500 cubic feet**

Authority: IC 22-13-2-2  
Affected: IC 22-12-7; IC 22-13; IC 22-14; IC 36-8-17

**Sec. 271. In Section 2904.4, change “approved” to “listed”.** (*Fire Prevention and Building Safety Commission; 675 IAC 22-2.3-271*)

**675 IAC 22-2.3-272 Section 2905.1; bale size and separation**

Authority: IC 22-13-2-2  
Affected: IC 22-12-7; IC 22-13; IC 22-14; IC 36-8-17

**Sec. 272. Add a sentence to the end of Section 2905.1 to read as follows: Automatic sprinkler protection shall be provided for interior storage of quantities exceeding 1,000 cubic feet.** (*Fire Prevention and Building Safety Commission; 675 IAC 22-2.3-272*)

**675 IAC 22-2.3-273 Section 3001.2; permits**

Authority: IC 22-13-2-2  
Affected: IC 22-12-7; IC 22-13; IC 22-14; IC 36-8-17

**Sec. 273. Delete Section 3001.2 without substitution.** (*Fire Prevention and Building Safety Commission; 675 IAC 22-2.3-273*)

**675 IAC 22-2.3-274 Section 3003.3.1; security of areas**

Authority: IC 22-13-2-2  
Affected: IC 22-12-7; IC 22-13; IC 22-14; IC 36-8-17

**Sec. 274. In Section 3003.3.1, delete “in an approved manner”.** (*Fire Prevention and Building Safety Commission; 675 IAC 22-2.3-274*)

**675 IAC 22-2.3-275 Section 3003.13; lighting**

Authority: IC 22-13-2-2  
Affected: IC 22-12-7; IC 22-13; IC 22-14; IC 36-8-17

**Sec. 275. In Section 3003.1.3, delete “approved”.** (*Fire Prevention and Building Safety Commission; 675 IAC 22-2.3-275*)

**675 IAC 22-2.3-276 Section 3101.2; permits**

Authority: IC 22-13-2-2  
Affected: IC 22-12-7; IC 22-13; IC 22-14; IC 36-8-17

**Sec. 276. Delete Section 3101.2 without substitution.** (*Fire Prevention and Building Safety Commission; 675 IAC 22-2.3-276*)

## Proposed Rules

### 675 IAC 22-2.3-277 Section 3102.1; definitions

Authority: IC 22-13-2-2

Affected: IC 22-12-7; IC 22-13; IC 22-14; IC 36-8-17

Sec. 277. In Section 3102.1, in the definition of **CORROSIVE**, delete “, Part 173” and insert “173.137”. (*Fire Prevention and Building Safety Commission; 675 IAC 22-2.3-277*)

### 675 IAC 22-2.3-278 Section 3201.2; permits

Authority: IC 22-13-2-2

Affected: IC 22-12-7; IC 22-13; IC 22-14; IC 36-8-17

Sec. 278. Delete Section 3201.2 without substitution. (*Fire Prevention and Building Safety Commission; 675 IAC 22-2.3-278*)

### 675 IAC 22-2.3-279 Section 3202.1; definitions

Authority: IC 22-13-2-2

Affected: IC 22-12-7; IC 22-13; IC 22-14; IC 36-8-17

Sec. 279. In Section 3202.1, in the definition of **CRYOGENIC FLUID**, delete “liquid” and insert “fluid”. (*Fire Prevention and Building Safety Commission; 675 IAC 22-2.3-279*)

### 675 IAC 22-2.3-280 Section 3203.1.1; nonstandard containers

Authority: IC 22-13-2-2

Affected: IC 22-12-7; IC 22-13; IC 22-14; IC 36-8-17

Sec. 280. In Section 3203.1.1, delete item 6. (*Fire Prevention and Building Safety Commission; 675 IAC 22-2.3-280*)

### 675 IAC 22-2.3-281 Section 3203.11; lighting

Authority: IC 22-13-2-2

Affected: IC 22-12-7; IC 22-13; IC 22-14; IC 36-8-17

Sec. 281. In Section 3203.11, delete “when required.”. (*Fire Prevention and Building Commission; 675 IAC 22-2.3-281*)

### 675 IAC 22-2.3-282 Section 3204.3.1.3; drainage

Authority: IC 22-13-2-2

Affected: IC 22-12-7; IC 22-13; IC 22-14; IC 36-8-17

Sec. 282. In Section 3204.3.1.3, delete the following from the Exception: “determined by the code official that”. (*Fire Prevention and Building Safety Commission; 675 IAC 22-2.3-282*)

### 675 IAC 22-2.3-283 Section 3204.3.2.2; drainage

Authority: IC 22-13-2-2

Affected: IC 22-12-7; IC 22-13; IC 22-14; IC 36-8-17

Sec. 283. In Section 3204.3.2.2, delete the exception without substitution. (*Fire Prevention and Building Safety Commission; 675 IAC 22-2.3-283*)

### 675 IAC 22-2.3-284 Section 3205.3.2; emergency shutoff valves

Authority: IC 22-13-2-2

Affected: IC 22-12-7; IC 22-13; IC 22-14; IC 36-8-17

Sec. 284. In Section 3205.3.2, delete “available” and

substitute “accessible”. (*Fire Prevention and Building Safety Commission; 675 IAC 22-2.3-284*)

### 675 IAC 22-2.3-285 Chapter 33; explosives and fireworks

Authority: IC 22-13-2-2

Affected: IC 8-2-7-43.5; IC 22-11-14; IC 22-12-7; IC 22-13; IC 22-14-4-2; IC 36-8-17

Sec. 285. (a) Delete the text of Chapter 33 and substitute as follows:

(b) Portions of this work are reproduced from the 1997 edition of the Uniform Fire Code, Article 77 and Article 78, copyright© 1997, with the permission of the publisher, the International Conference of Building Officials. ICBO assumes no responsibility for the accuracy or completion of summaries provided therein.

## CHAPTER 33 - EXPLOSIVES AND FIREWORKS

### SECTION 3. - GENERAL

**3301.1 Scope.** Manufacture, possession, storage, sale, transportation and use of explosive materials shall be in accordance with Chapter 33. See Appendix VI-F for excerpts from nationally recognized standards for separation distances for explosives.

Explosives class designations in parentheses refer to new classifications used by DOT. See Appendix VI-F for information on explosives class designations.

**EXCEPTIONS: 1.** The armed forces of the United States, Coast Guard or National Guard.

**2.** Explosives in forms prescribed by the official United States Pharmacopoeia.

**3.** The sale, possession or use of fireworks 1.4G (Class C common fireworks).

**4.** The possession, transportation, storage and use of small arms ammunition when packaged in accordance with DOT packaging requirements.

**5.** The possession, storage, transportation and use of not more than 5 pounds (2.27 kg) of commercially manufactured sporting black powder, 20 pounds (9.07 kg) of smokeless powder and 10,000 small arms primers for hand loading of small arms ammunition for personal consumption.

**6.** The transportation and use of explosive materials by the United States Bureau of Mines, and federal, state and local law enforcement and fire agencies acting in their official capacities.

**7.** Special industrial explosive devices which in the aggregate contain less than 50 pounds (22.7 kg) of explosive materials.

**8.** The possession, transportation, storage and use of blank industrial powder load cartridges when packaged in accordance with DOT packaging regulations.



9. When preempted by federal regulations.

10. The use and handling of fireworks 1.3G (Class B fireworks) as set forth in Chapter 33.

### 3301.2 Definitions.

#### 3301.2.1 General. Insert the following definitions:

**AERIAL SHELL** is a pyrotechnic device that functions in the air.

**BATF** is the Bureau of Alcohol, Tobacco and Firearms.

**BLASTING AGENT** is a material or mixture consisting of a fuel and oxidizer intended for blasting. The finished product as mixed and packaged for use or shipment cannot be detonated by means of a No. 8 test blasting cap when unconfined. Under Department of Transportation regulations, blasting agents are classified and labeled as 1.5D.

**BLASTING CAP** is a shell closed at one end and containing a charge of a detonating compound which is ignited by a safety fuse. It is used for detonating explosives.

**BINARY EXPLOSIVE** is an explosive material composed of separate components, each of which is safe for storage and transportation and would not in itself be considered as an explosive.

**BREAK (aerial shell)** is an individual effect from an aerial shell, generally either color or noise. Aerial shells can be single break, having only one effect, or multiple break, having two or more effects.

**BULLET RESISTANT** is a material or method of construction which resists penetration of a bullet of 150 grain (9.75 g) M-2 ball ammunition having a nominal muzzle velocity of 2,700 feet per second (823 m/s) fired from a .30 caliber rifle at a distance of 100 feet (30.5 m). See Section 3302.3.4.

**C.F.R.** is the Code of Federal Regulations of the United States Government.

**DEA** is the Drug Enforcement Administration of the United States Department of Justice.

**DEFLAGRATION** is an exothermic reaction, such as the extremely rapid oxidation of a combustible dust or flammable vapor in air, in which the reaction progresses through the unburned material at a rate less than the velocity of sound. A deflagration can have an explosive effect.

**DESIGNATED LANDING AREA** is the area over which aerial shells are fired and into which debris and malfunctioning aerial shells can fall.

**DETONATION** is an exothermic reaction characterized by

the presence of a shock wave in a material which establishes and maintains the reaction. The reaction zone progresses through the material at a rate greater than the velocity of sound. The principal heating mechanism is one of shock compression. Detonations have an explosive effect.

**DETONATOR** is a component, such as a blasting cap or an electric blasting cap, in an explosive train which is capable of initiating detonation in a subsequent high explosive component.

**DOT** is the United States Department of Transportation.

**ELECTRIC BLASTING CAP** is a detonator which consists of a shell closed at one end. The other end contains electric wires which have been sealed into the shell. It contains a charge of detonating compound which is ignited or initiated by applying electric current to the wires protruding from the detonator.

**EXPLOSIVE** is:

1. A chemical that causes a sudden, almost instantaneous release of pressure, gas and heat when subjected to sudden shock, pressure, or high temperatures, or
2. A material or chemical, other than a blasting agent, that is commonly used or intended to be used for the purpose of producing an explosive effect and is regulated by Chapter 33.

**EXPLOSIVE MATERIALS** are explosives, blasting agents and detonators including, but not limited to, dynamite and other high explosives; slurries, emulsions and water gels; black powder and pellet powder; initiating explosives; detonators or blasting caps; safety fuses; squibs; detonating cord; igniter cord; igniters and fireworks, 1.3G (Class B special fireworks).

**FIREWORKS, 1.4G (Class C, Common)** are small firework devices designed primarily to produce visible or audible effects by combustion and which comply with the construction, chemical composition and DOT labeling requirements for fireworks, 1.4G (Class C, common fireworks).

**FIREWORKS, 1.3G (Fireworks, Special Class B)** are large fireworks designed primarily to produce visible or audible effects by combustion, deflagration or detonation. Fireworks, 1.3G (special fireworks) include, but are not limited to, firecrackers containing more than 2 grains (130 m) of explosive composition, aerial shells containing more than 40 grms of pyrotechnic composition and other display pieces which exceed the limits for classification as 1.4G (Class C, common fireworks).

Special fireworks formerly classified as Class B explosives are now classified as fireworks, 1.3G by DOT.

**FIXED GROUND PIECE** is a ground display piece having no movable parts, such as a revolving wheel.

---

## Proposed Rules

---

**GROUND PIECE** is a pyrotechnic device that functions on the ground. Ground pieces include fountains, roman candles, wheels and set pieces.

**GUNPOWDER** is any of various powders used in firearms and small arms ammunition as propelling charges.

**HIGH EXPLOSIVE** is explosive material, such as dynamite, which can be caused to detonate by means of a No. 8 test blasting cap when unconfined.

**INHABITED BUILDING** is a building regularly occupied in whole or in part as a habitation for human beings. Inhabited buildings include churches, schools, railway passenger stations, stores, airport terminals for passengers, and other buildings or structures where people are accustomed to congregate or assemble. Inhabited buildings do not include buildings or structures occupied in connection with the manufacture, transportation, storage or use of explosives and blasting agents.

**INTRAPLANT DISTANCE** is the minimum distance permitted between two buildings on an explosives manufacturing site, when at least one of the buildings contains or is designed to contain explosives.

**LOW EXPLOSIVE** is explosive material which will burn or deflagrate when ignited. It is characterized by a rate of reaction that is less than the speed of sound. Examples of low explosives are black powder, safety fuse, igniters, igniter cord, fuse lighters, fireworks, 1.3G (Class B special fireworks), 1.3, propellants (Class B solid propellants), and fireworks, 1.4G (Class C common fireworks).

**MAGAZINE** is a building or structure used for the storage of explosives.

**MASS-DETONATING EXPLOSIVES** are high explosives, black powder, certain propellants, certain pyrotechnics and other similar explosives, alone or in combination, or loaded into various types of ammunition or containers, most of which can be expected to explode virtually instantaneously when a small portion is subjected to fire, severe concussion, impact, the impulse of an initiating agent, or the effect of a considerable discharge of energy from without. Such an explosive will normally cause severe structural damage to adjacent objects. Explosives propagation could occur immediately to other items of ammunition and explosives stored sufficiently close to and not adequately protected from the initially exploding pile with a time interval short enough so that two or more quantities must be considered as one for quantity/distance (Q/D) purposes.

**MORTAR** is a tube from which aerial shells are fired.

**PERCUSSION CAP** is a device used to ignite the powder charge of small arms ammunition.

**PYROTECHNIC OPERATOR** is an individual approved to be responsible for pyrotechnic, pyrotechnic special effects materials or both.

**PYROTECHNIC SPECIAL EFFECTS MATERIAL** (special effect) is a low explosive material, other than detonating cor, commonly used in motion picture, television, theatrical or group entertainment production for which a permit from the chief is required for use or storage.

**READY BOX** is a storage container for aerial shells at the site of a fireworks display.

**SAFETY CAP** is a paper tube, closed at one end, that is placed over the end of the fuse of an aerial shell to protect it from accidental ignition.

**SPECIAL INDUSTRIAL EXPLOSIVE DEVICE** is an explosive power-pack containing an explosive charge in the form of a cartridge or construction device. The term includes, but is not limited to, explosive rivets, explosive bolts, explosive charges for driving pins or studs, cartridges for explosive-actuated power tools and charges of explosives used in jet tapping of open-hearth furnaces and jet perforation of oil well casings.

**SPECIAL INDUSTRIAL HIGH-EXPLOSIVE MATERIALS** are sheet, extrusions, pellets and packages of high explosives containing dynamite, trinitrotoluol, pentaerythritoltetranite, cyclotrimethylenetrinitramine or other similar compounds used for high-energy-rate forming, expanding and shaping in metal fabrication and for dismemberment and quick reduction of scrap metal.

**SQUIB, ELECTRIC**, is a device similar in appearance to an electric blasting cap which, upon activation by an electric current, produces a deflagration instead of a detonation.

**TEST BLASTING CAP NO. 8** is a blasting cap containing 2 grams of a mixture of 80 per cent mercury fulminate and 20 percent potassium chlorate or a cap of equivalent strength.

For other fireworks definitions, see also IC 22-11-14.

**3301.2.2 Limited application.** For the purpose of Chapter 33, certain terms are defined as follows:

**DISPLAY** is an outdoor display of aerial shells or ground display pieces.

**FIRE RESISTANT** is construction designed to provide reasonable protection against fire. For exterior walls of magazines constructed of wood, this shall mean fire-resistance equivalency provided by sheet metal of not less than 0.0179 inch (0.45 mm) (26 manufacturer's standard gage).

**HARDWOOD** is red oak, white oak, hard maple, ash or hickory, each of which is free from knots, wind shakes or similar defects.

**PLYWOOD** is A-C exterior grade plywood.

**SOFTWOOD** is Douglas fir, pine or other softwood of equal bullet-resistance free from loose knots, wind shakes or similar defects.

**STEEL** is general purpose, hot- or cold-rolled, low carbon steel.

**TEMPORARY STORAGE** is storage of pyrotechnic special effects material on site for a period of time of 72 hours or less.

**3301.3 Permits.**

**3301.3.1 Required.** Permits shall be as required in IC 22-14-4 and 675 IAC 12-9-4.

**3301.3.2 Unsafe material or practice.** Permits for the following materials shall be invalidated and the materials disposed of in an approved, safe manner:

1. Dynamite having an unsatisfactory absorbent or one that permits leakage of a liquid explosive ingredient under any conditions liable to exist during storage.
2. Nitrocellulose in a dry and uncompressed condition in quantity greater than 10 pounds (4.5 kg) net weight in one package.
3. Fulminate of mercury in a dry condition and fulminate of other metals in any condition except as a component of manufactured articles not hereinafter forbidden.
4. Explosive compositions that ignite spontaneously or under-go marked decomposition, rendering the products or their use more hazardous, when subjected for 48 consecutive hours or less to a temperature of 167°F (75°C).
5. New explosive materials until approved by DOT.
6. Explosive materials condemned by DOT.
7. Explosives containing an ammonium salt and a chlorate.

**3301.4 Bond.** See IC 22-14-4-2.

**3301.5 Notice of New Storage and Manufacturing Sites.** When a new explosive material storage or manufacturing location, including a temporary jobsite, is established, the local law enforcement agency, fire department and emergency planning committee shall be notified immediately of the type, quantity and location of explosive materials at the site.

**3301.6 Access Road Signs.** At the entrance to explosive material manufacturing and storage sites, all access roads

shall be posted with the following warning sign or other approved sign:

**DANGER**  
**NEVER FIGHT EXPLOSIVE FIRES**  
**EXPLOSIVES ARE STORED ON THIS SITE**  
**CALL \_\_\_\_\_**

The sign shall be weather resistant with a reflective surface and lettering at least 2 inches (50.8 mm) high.

**3301.7 Prohibited and Limited Acts.**

**3301.7.1 Manufacturing.** The manufacture of explosives shall be prohibited unless such manufacture is in accordance with IC 22-14-4.

**3301.7.2 Limits established by law.** Storage of explosive materials is prohibited within the limits established by law as the limits of districts in which such storage is prohibited.

## **SECTION 4. STORAGE**

**3302.1 General.**

**3302.1.1 Magazines required.** Explosive materials shall be stored in magazines in accordance with Section 3302.

A competent person shall be in charge of magazines. The person shall be at least 21 years of age and responsible for compliance with all safety precautions.

**3302.1.2 Inspection.** Magazines containing explosive materials shall be inspected at intervals of not greater than seven days to determine whether there has been an unauthorized entry or attempted entry into a magazine, or unauthorized removal of a magazine or its contents.

**3302.1.3 Security.** Magazine doors shall be kept locked when the magazine is unattended.

**3302.1.4 Posting safety rules.** Current safety rules covering the operations of magazines shall be posted on the interior of each magazine in a visible location.

**3302.1.5 Rotating stock.** When explosive material is removed from a magazine for use, the oldest usable stocks shall be removed first.

**3302.1.6 Manner of storage.** Corresponding grades and brands shall be stored together and in such a manner that grades and brand marks are visible. Stocks shall be stored so as to be easily counted and checked.

Packages of explosive materials shall be stacked in a stable manner not exceeding 6 feet (1,829 mm) in height.

**3302.1.7 Opened stock.** Packages of explosive materials which have been opened shall be closed before being placed

---

---

## Proposed Rules

---

---

in a magazine. Packages constructed of materials other than fiberboard or paper shall not be opened in a magazine.

**3302.1.8 Damaged material.** Packages of damaged explosive materials shall not be unpacked or repacked in or within 50 feet (15,240 mm) of a magazine or inhabited building or in close proximity to other explosive materials.

**3302.1.9 Storage with other materials.** Magazines shall be used exclusively for the storage of approved explosive materials and other blasting materials. Tools, other than approved conveyors, shall not be stored in magazines.

**3302.1.10 Cleaning.** Magazine floors shall be swept regularly and shall be kept clean, dry and free of grit, paper and rubbish. Sweepings from floors of magazines shall be disposed of in accordance with the instructions of the manufacturer.

**3302.1.11 Deteriorated material handling.** When an explosive material has deteriorated to an extent that it is in an unstable or dangerous condition, or when a liquid has leaked from an explosive material, the person in possession of such explosive material shall immediately contact the material's manufacturer and the chief. The work of destroying explosive materials shall be directed by persons experienced in the destruction of explosive materials. Explosive materials recovered from blasting misfires shall be placed in a magazine until an experienced person has determined the method of disposal.

**3302.1.12 Stained floors.** Magazine floors stained with liquid shall be dealt with according to instructions obtained from the manufacturer of the explosive materials stored in the magazine.

**3302.1.13 Magazine maintenance.** When magazines need interior repairs, all explosive materials shall be removed and the floors cleaned before and after making repairs. When making exterior magazine repairs involving the possibility of causing a fire, all explosive materials shall first be removed from the magazine. Explosive materials removed from a magazine under repair shall be placed either in another magazine or placed a safe distance from the magazine, where they shall be properly guarded and protected until repairs have been completed. Upon completion of repairs, the explosive materials shall be promptly returned to the magazine.

**3302.1.14 Sources of ignition.** Smoking, matches, flame-producing devices, open flames and firearms or cartridges shall not be permitted inside of or within 50 feet (15,240 mm) of magazines.

Where low explosives are sorted in magazines, spark-producing tools shall not be used. Such magazines shall be bonded and grounded.

**3302.1.15 Yard maintenance.** The land within 25 feet (7,620 mm) of magazines shall be kept clear of rubbish, brush, dried grass, leaves, dead trees, and live trees less than 10 feet (3,048 mm) high.

Combustible materials shall not be stored within 50 feet (15,240 mm) of magazines.

**3302.1.16 Premises identification.** The premises upon which Types 1, 2, 4 and 5 outdoor magazines are located shall be posted with signs reading EXPLOSIVES—KEEP OFF. These signs shall be in contrasting colors with a minimum letter size of 3-inch (76 mm) height with ½ inch (12.7 mm) brush stroke. Signs shall be located so that a bullet passing through the sign will not strike a magazine. Signs shall not be attached to outdoor magazines.

**3302.1.17 Location.** Types 1, 2, 4, and 5 outdoor magazines shall be located in accordance with nationally recognized standards. See Appendix VI-F.

### 3302.2 Retail Sales.

**3302.2.1 General.** Indoor storage and display of gunpowder and ammunition for retail sales shall be in accordance with Section 3302.2.

**3302.2.1.1 Storage.** The maximum quantities, storage conditions, and fire-protection requirements for gunpowder and ammunition stored in a building shall be as follows:

1. Smokeless powder:

200 pounds (90.7 kg) in a Type 4 magazine, or  
400 pounds (181.4 kg) in separate portable Type 4 magazines in a completely sprinklered building. The quantity of product in a magazine shall not exceed 200 pounds (90.7 kg).

2. Commercially manufactured sporting black powder:  
25 pounds (11.3 kg) in a separate, portable Type 4 magazine.

3. Small arms primers or percussion caps:

750,000 with not more than 100,000 stored in one pile and piles separated from each other by at least 15 feet (4572 mm), or

Greater than 750,000, when in accordance with the following:

3.1 The storage room shall not be accessible to unauthorized persons,

3.2 Primers or percussions caps shall be stored in a 1-inch (25.4 mm) nominal thickness wood cabinet or equivalent with self-closing doors with not more than 200,000 primers or caps per cabinet,

3.3 Shelves in cabinets shall be vertically separated by at least 2 feet (6,096 mm),

3.4 Cabinets shall be located against walls of the storage room with at least 40 feet (12,192 mm) be-

tween cabinets, or with at least 20 feet (6,096 mm) between cabinets when barricades are installed midway between cabinets. Such barricades shall be securely attached to the wall, shall project from the wall at least 10 feet (3,048 mm) and shall be at least twice the height of cabinets. Barricade construction shall be of ¼-inch (6.4 mm) boiler plate or 2 inches (50.8 mm) of wood, brick or concrete block.

3.5 Primers or percussion caps shall be separated from flammable liquids, flammable solids and oxidizing materials by a distance of 25 feet (7,620 mm) or by a fire partition having a fire-resistive rating of at least one hour, and

3.6 The building shall be protected by an automatic sprinkler system.

3302.2.1.2 Display. The maximum quantities, storage conditions, and fire-protection requirements for gunpowder and ammunition displayed in a building shall be as follows:

1. Smokeless powder: 20 pounds (9.07 kg) in original containers.
2. Black powder: NONE.
3. Small arms primers or percussion caps: 10,000 in a nonsprinklered building. 25,000 in a sprinklered building.

3302.2.2 Magazine size. Indoor magazines shall not be of a size greater than the exit door or contain more than 200 pounds (90.7 kg) of explosive materials.

3302.2.3 Powder. The amount of powder stored in an indoor magazine shall not exceed 200 pounds (90.7 kg).

3302.2.4 Combined storage. Black powder shall not be stored with small arms primers or percussion caps.

3302.2.5 Bulk repackaging. The bulk repackaging of powder, primers or percussion caps shall not be performed in retail stores.

3302.2.6 Repackaging of damaged containers. Damaged containers shall not be repackaged.

3302.2.7 Separation. Buildings containing gunpowder or ammunition in accordance with Section 3302.2 need not be located as required by Section 3302.3.3.

**3302.3 Storage Magazines.**

3302.3.1 General. Explosive materials, including special industrial high-explosive materials, shall be stored in magazines which meet the requirements of Section 3302.3.

3302.3.2 Classification and use of magazines. Magazines shall be classed as Type 1, 2, 3, 4 or 5. Magazines shall be constructed and used in accordance with Table 3302.3-A.

**TABLE 3302.3-A - TYPES OF MAGAZINES REQUIRED FOR STORAGE OF EXPLOSIVE MATERIALS**

<b>MATERIALS</b>	<b>MAGAZINE TYPES<sup>1</sup></b>				
	<b>1</b>	<b>2</b>	<b>3</b>	<b>4</b>	<b>5</b>
High Explosives, 1.1D, (Class A explosives) including dynamites; cap sensitive emulsions; slurries and watergels; cast boosters.	X	X	X		
Black Powder, 1.1D, (Class A explosives). Defined as low explosive by the Bureau of Alcohol, Tobacco and Firearms for storage.	X	X	X	X	
Detonators, 1.1B, (Class A explosives)	X	X	X		
Detonating Cords, 1.1D; 1.2D; 1.4D; 1.4G, (Class A or C explosive)	X	X	X		
Detonators <sup>2</sup> , 1.4B; 1.4S, (Class C explosive)	X	X	X	X	
Safety fuse, electric squibs, igniters and igniter cord <sup>3</sup> , 1.4G; 1.4S.	X	X	X	X	
Blasting Agents, 1.5D, (Blasting Agents)	X	X	X	X	X
Propellants, 1.3C, (Class B explosives). Defined as low explosives by the Bureau of Alcohol, Tobacco and Firearms for storage.	X	X	X	X	

<sup>1</sup>Any of the types indicated by "X" are allowed.

<sup>2</sup>Includes electric detonators with leg wires 4 feet (1219 mm) long or longer or detonators with empty plastic tubing 12 feet (3657.6 mm) long or longer that contain not more than 1 gram of explosives (excluding ignition and delay charges).

<sup>3</sup>Detonators shall not be stored in the same magazine with other explosive materials, except that 1.4 (Class C) detonators and those described in Footnote 2 are allowed to be stored with safety fuse, electric squibs, igniters or igniter cord in Type 1, 2, 3 or 4 magazines.

3302.3.3 Location. Site magazines for the storage of high explosives and blasting agents shall be located in accordance with Appendix VI-F. Magazines for the storage of low explosives shall be located in accordance with Appendix VI-F. The ground around outdoor magazines shall be graded such that water drains away from the magazines.

**3302.3.4 Bullet-resistant construction.**

3302.3.4.1 General. Magazines which are required to be bullet resistant shall be constructed using a method specified in Section 3302.3.4. Steel and wood dimensions indicated are actual thicknesses. Concrete block and brick

---

---

## Proposed Rules

---

---

dimensions indicated are the manufacturer's represented thicknesses.

**3302.3.4.2 Specified construction.** The following methods are acceptable as bullet-resistant construction:

1. Exterior of  $\frac{5}{8}$  inch (15.9 mm) steel, lined with an interior of any type of nonsparking material.
2. Exterior of  $\frac{1}{2}$  inch (12.7 mm) steel, lined with an interior of not less than  $\frac{3}{8}$  inch (9.5 mm) plywood.
3. Exterior of  $\frac{3}{8}$  inch (9.5 mm) steel, lined with an interior of 2 inches (50.8 mm) of hardwood.
4. Exterior of  $\frac{3}{8}$  inch (9.5 mm) steel, lined with an interior of 3 inches (76.2 mm) of softwood or  $2\frac{1}{4}$  inches (57.2 mm) of plywood.
5. Exterior of  $\frac{1}{4}$  inch (6.4 mm) steel, lined with an interior of 3 inches (76.2 mm) of hardwood.
6. Exterior of  $\frac{1}{4}$  inch (6.4 mm) steel, lined with an interior of 5 inches (127 mm) of softwood or  $5\frac{1}{4}$  inches (133.4 mm) of plywood.
7. Exterior of  $\frac{1}{4}$  inch (6.4 mm) steel, lined with an intermediate layer of 2 inches (50.8 mm) of hardwood and an interior lining of  $1\frac{1}{2}$  inches (38.1 mm) of plywood.
8. Exterior of  $\frac{3}{16}$  inch (4.8 mm) steel, lined with an interior of 4 inches (101.6 mm) of hardwood.
9. Exterior of  $\frac{3}{16}$  inch (4.8 mm) steel, lined with an interior of 7 inches (177.8 mm) of softwood or  $6\frac{1}{4}$  inches (171.4 mm) of plywood.
10. Exterior of  $\frac{3}{16}$  inch (4.8 mm) steel, lined with an intermediate layer of 3 inches (76.2 mm) of hardwood and an interior lining of  $\frac{3}{4}$  inch (19.1 mm) of plywood.
11. Exterior of  $\frac{1}{8}$  inch (3.2 mm) steel, lined with an interior of 5 inches (127 mm) of hardwood.
12. Exterior of  $\frac{1}{8}$  inch (3.2 mm) steel, lined with an interior of 9 inches (228.6 mm) of softwood.
13. Exterior of  $\frac{1}{8}$  inch (3.2 mm) steel, lined with an intermediate layer of 4 inches (101.6 mm) of hardwood and an interior lining of  $\frac{3}{4}$  inch (19.1 mm) plywood.
14. Exterior of any type of fire-resistant material which is structurally sound, lined with an intermediate layer of 4 inches (101.6 mm) of solid concrete block or 4 inches (101.6 mm) of solid brick or 4 inches (101.6 mm) of solid concrete, and an interior lining of  $\frac{1}{2}$  inch (12.7 mm) plywood placed securely against the masonry lining.
15. Standard 8 inch (203.2 mm) concrete block with voids filled with a well-tamped sand/cement mixture.
16. Standard 8 inch (203.2 mm) solid brick.
17. Exterior of any type of fire-resistant material which is structurally sound, lined with an intermediate 6 inch (152.4 mm) space filled with well-tamped dry sand or a well-tamped sand/cement mixture.
18. Exterior of  $\frac{1}{8}$  inch (3.2 mm) steel, lined with a first intermediate layer of  $\frac{3}{4}$  inch (19.1 mm) plywood, a second intermediate layer of  $3\frac{5}{8}$  inches (92.1 mm) of a well-tamped dry sand or sand/cement mixture and an interior lining of  $\frac{3}{4}$  inch (19.1 mm) plywood.

19. Exterior of any type of fire-resistant material, lined with a first intermediate layer of  $\frac{3}{4}$  inch (19.1 mm) plywood, a second intermediate layer of  $3\frac{5}{8}$  inches (92.1 mm) of a well-tamped dry sand or sand/cement mixture, a third intermediate layer of  $\frac{3}{4}$  inch (19.9 mm) plywood, and a fourth intermediate layer of 2 inches (50.8 mm) of hardwood or not less than 0.068 inch (1.7 mm) of steel and an interior lining of  $\frac{3}{4}$  inch (19.1 mm) plywood.
20. Eight inch thick (203.2 mm) solid concrete.

**3302.3.4.3 Tested construction.** Methods of construction other than those specified in Section

3302.3.4.2 are acceptable as bullet-resistant construction when tested as prescribed herein. Tests to determine bullet resistance shall be conducted on test panels or empty magazines which shall resist five out of five shots placed independently of each other in an area 3 feet by 3 feet (914.4 mm by 914.4 mm). For ceilings and roofs, the bullet shall be fired at an angle of 45 degrees from the perpendicular. For walls and doors, the bullet shall be fired perpendicular to the wall or door. See BULLET RESISTANT in this section.

**3302.3.5 Type 1 magazines.**

**3302.3.5.1 General.** Type 1 magazines shall be constructed in accordance with the Building Code and Section 3302.3.5.

A Type 1 magazine shall be a permanent structure such as a building, igloo, tunnel or dugout. It shall be bullet resistant, fire resistant, weather resistant, theft resistant and ventilated.

**3302.3.5.2 Walls.** Walls shall be bullet resistant as specified in Section 3302.3.4.

**3302.3.5.3 Floors.** Floors shall be constructed of wood or other suitable nonsparking materials.

**3302.3.5.4 Foundations.** Foundations shall be constructed of brick, concrete, cement block, stone or wood posts. If piers or posts are used in lieu of a continuous foundation, the space under the buildings shall be enclosed with fire-resistant materials.

**3302.3.5.5 Bullet-resistant roofs or ceilings.** Where it is possible for a bullet to be fired directly through the roof and into the magazine at such an angle that the bullet could strike the explosives within, the magazine roof shall be bullet resistant as specified in Section 3302.3.4 or shall be protected by one of the following methods:

1. A sand tray having a depth of 4 inches (101.6 mm) of sand and located at the top of the inner walls covering the entire ceiling area, except that portion necessary for ventilation.

2. Either not less than 0.033 inch (0.84 mm) (20 gage) steel with 4 inches (101.6 mm) of hardwood or not less than 0.043 inch (1.1 mm) (18 gage) aluminum with 7 inches (177.8 mm) of hardwood.

**3302.3.5.6 Doors.** Doors shall be bullet resistant as specified in Section 3302.3.4. Hinges and hasps shall be attached to the doors by welding, riveting, or bolting with nuts on the inside of the door. Hinges and hasps shall be installed in such a manner that they cannot be removed when the doors are closed and locked.

**3302.3.5.7 Locks.** Each door shall be equipped with two mortise locks, two padlocks fastened in separate hasps and staples, a combination of a mortise lock and a padlock, a mortise lock that requires two keys to open, or a three-point or equivalent-type lock that secures the door to the frame at more than one point. Padlocks shall be steel having at least five tumblers and at least a 3/8 inch (9.5 mm) diameter case-hardened shackle. Padlocks shall be protected by not less than 1/4 inch (6.4 mm) steel hoods constructed in a manner which prevents sawing or lever action on the locks, hasps and staples.

**EXCEPTION:** Magazine doors that are adequately secured on the inside by means of a bolt, lock or bar that cannot be actuated from the outside.

**3302.3.5.8 Ventilation.** Ventilation shall be provided to prevent dampness and heating of stored explosive materials. Ventilation openings shall be screened to prevent the entrance of sparks. Ventilation openings in side walls and foundations shall be offset or shielded for bullet-resistant purposes. Magazines having foundation and roof ventilators with the air circulating between the side walls and the floors and between the side walls and the ceiling shall have a wooden lattice or equivalent to prevent the packages of explosive materials from being stacked against the side walls and blocking the air circulation.

**3302.3.5.9 Exposed metal.** Sparking material shall not be exposed to contact with the stored explosive materials. Ferrous metal nails in the floor and side walls, which could be exposed to contact with explosive materials shall be blind nailed, counter sunk or covered with a nonsparking lattice-work or other nonsparking material.

**3302.3.6 Type 2 magazines.** Type 2 magazines shall be constructed in accordance with Section 3302.3.6.

A Type 2 magazine shall be a box, trailer, semitrailer or other mobile facility.

A Type 2 magazine shall be bullet resistant, fire resistant, weather resistant, theft resistant and ventilated.

Walls, ceiling and roof construction, hinges, hasps, locks, ventilation, and interior construction shall be constructed as required for Type 1 magazines.

Type 2 magazines shall be supported to prevent the floor from having direct contact with the ground. Magazines less than 1 cubic yard (0.76 m<sup>3</sup>) in size shall be fastened to a fixed object to prevent theft of the entire magazine.

Vehicular magazines shall be immobilized by removing the wheels, locking with a kingpin locking device or other approved methods.

**3302.3.7 Type 3 magazines.** Type 3 magazines shall be constructed in accordance with Section 3302.3.7.

A Type 3 magazine shall be a "day box" or other portable magazine. Type 3 magazines shall be theft resistant, fire resistant and weather resistant.

Type 3 magazines shall be constructed of not less than 0.097 inch (2.5 mm) (12 gage) steel lined with at least 1/2 inch (12.7 mm) plywood or masonite. Doors shall overlap sides by at least 1 inch (25.4 mm).

Hinges and hasps shall be attached by welding, riveting or bolting with nuts on the inside. Type 3 magazines shall have one steel padlock having at least five tumblers and a case-hardened shackle of at least 3/8 inch (9.5 mm) diameter.

Explosive materials shall not be left unattended in a Type 3 magazine. When Type 3 magazines will be left unattended, explosive materials shall first be moved to a Type 1 or 2 magazine.

**3302.3.8 Type 4 magazines.** Type 4 magazines shall be constructed in accordance with the Building Code and Section 3302.3.8.

A Type 4 magazine shall be a permanent, portable or mobile structure, such as a building, igloo, box, semitrailer or other mobile container, which shall be fire resistant, theft resistant and weather resistant.

Outdoor magazines shall be constructed of masonry, metal-covered wood, fabricated metal, or a combination of these materials. Doors shall be metal or solid wood covered with metal.

Permanent magazines shall be constructed as required for Type 1 magazines with respect to foundations, floors, ventilation and locking devices. Vehicular magazines shall be immobilized when unattended as required for Type 2 magazines.

**3302.3.9 Type 5 magazines.** Permanent Type 5 magazines shall be constructed in accordance with the Building Code and Section 3302.3.9. Temporary Type 5 magazines shall be constructed in accordance with Section 3302.3.9.

A Type 5 magazine shall be a building, igloo, box, bin, tank, semitrailer, bulk-trailer, tank trailer, bulk truck, tank truck or other mobile container.

Outdoor Type 5 magazines shall be weather resistant and theft resistant.

Construction shall be of wood, wood covered with metal, masonry, fabricated metal or a combination of these

---

---

## Proposed Rules

---

---

materials. Doors shall be metal or solid wood.

Permanent Type 5 magazines shall be constructed as required for Type 1 magazines with respect to foundations, floors, ventilation and locking devices.

Vehicular magazines shall be immobilized when unattended, as required for Type 2 vehicular magazines.

Over-the-road trucks and semitrailers used for temporary storage shall have each door locked with one steel padlock having at least five tumblers and a case-hardened shackle of at least 3/8-inch (9.5 mm) diameter. The door hinges and lock hasp shall be securely fastened to the magazine and the door frame.

**EXCEPTION:** Magazine doors that are adequately secured on the inside by means of a bolt, lock or bar that cannot be actuated from the outside.

Type 5 storage magazines in trailers shall display **BLASTING AGENT** placards, as required by Section 3303.2.10 on the trailer when any quantity of blasting agents (Explosives, 1.5D - see Appendix VI-F) is contained therein.

**3302.3.10 Indoor magazines.** Indoor magazines shall be constructed in accordance with Section 3302.3.10.

Indoor magazines shall be fire resistant and theft resistant. Indoor magazines constructed of wood shall have sides, bottoms and lids or doors constructed of 2 inch (50.8 mm) wood and shall be well braced at corners. The magazines shall be covered on the exterior with steel not less than 0.016 inch (0.41 mm) (26 gage) thick. Indoor magazines constructed of metal shall have sides, bottoms and lids or doors constructed of not less than 0.097 inch (2.5 mm) (12 gage) steel and shall be lined with a minimum of 1/2 inch (12.7 mm) of nonsparking material.

**EXCEPTION:** Type 5 indoor magazines used for the storage of blasting agents (Explosives, 1.5D—see Appendix VI-F) need not be fire resistant.

Indoor magazines need not be bullet resistant or weather resistant if the buildings in which they are stored provide protection from the weather and bullet penetration.

Hinges and hasps shall be attached to doors or lids by welding, riveting or bolting with nuts on the inside so that doors or lids cannot be removed when closed and locked. Each magazine shall be equipped with a steel padlock, which need not be protected by a steel hood, having at least five tumblers with a case-hardened shackle of at least 3/8-inch (9.5 mm) diameter.

Indoor magazines shall have substantial wheels or casters to facilitate removal from a building in case of emergency.

Magazines shall be painted red and the lid or door shall bear in conspicuous white lettering, at least 3 inches (76.2 mm) high, **EXPLOSIVES—KEEP FIRE AWAY**.

The indoor storage of high explosives shall not exceed 50 pounds (22.7 kg). Detonators shall be stored in a separate magazine from other explosive materials and the total number of detonators stored shall not exceed 5,000.

Indoor magazines containing blasting agents in excess of 50 pounds (22.7 kg) shall be located in accordance with Appendix VI-F.

Indoor storage magazines shall not be located in residences or dwellings.

### SECTION 3303 - USE, HANDLING AND TRANSPORTATION

#### 3303.1 Use and Handling.

**3303.1.1 Hours of operation.** Blasting operations shall be conducted during daylight hours.

**3303.1.2 Personnel qualifications.** The person in charge of the handling and use of explosive materials shall be at least 21 years of age and possess a valid explosive-use permit issued by the chief.

**EXCEPTION:** Persons 18 years of age or older are allowed to use and handle explosive materials under the direct personal supervision of a person who possesses a valid explosive-use permit.

**3303.1.3 Intoxicants.** Explosive materials shall not be handled by persons under the influence of intoxicants, narcotics or DEA-controlled substances.

**3303.1.4 Smoking.** Smoking and carrying matches while handling explosive materials or while within 50 feet (15 240 mm) of where explosive materials are being used are prohibited.

**3303.1.5 Sources of ignition.** The use of matches, lighters, spark-producing devices or the presence of any open flames is prohibited within 50 feet (15 240 mm) of areas where explosives are being used.

**EXCEPTION:** The lighting of safety fuse in conjunction with approved blasting operations.

**3303.1.6 Utilities notification.** When blasting is being conducted in the vicinity of gas, electric, water, fire alarm, telephone, telegraph or stream utilities, the blaster shall notify the appropriate representative of such utilities at least 24 hours in advance of blasting specifying the location and intended time of such blasting.

**3303.1.7 Other regulations.** Blasting operations shall be conducted in accordance with federal, state and local regulations.

**3303.1.8 Blasting safeguards.** Before a blast is fired, the person in charge shall make certain that surplus explosive materials are in a safe place, that persons and vehicles are at a safe distance or under sufficient cover, and that a loud warning signal has been sounded.

**3303.1.9 Premature detonation safeguards.** Precautions



shall be taken to prevent the premature detonation of explosive materials from lighting, radio frequency energy, extraneous electricity or static electricity caused by dust or snow storms, low humidity or mechanical conditions. Such precautions shall include:

1. The suspension of blasting operations and removal of persons from the blasting area during the approach and progress of a thunderstorm,
2. The posting of signs prohibiting the use of mobile radio transmitters on roads within 1,000 feet (304.8m) of blasting operations where electric detonators are being used, and
3. Periodic checks for static electricity or stray currents in areas where these factors could exceed safe operating limits.

**3303.1.10 Nonsparking tools.** Tools used for the opening of containers of explosive materials shall be made of nonsparking materials.

**EXCEPTION:** Slitters of metal are allowed for opening paper, plastic or fiberboard containers.

**3303.1.11 Exposure protection.** When blasting is performed in a congested area or in close proximity to a building, structure, railway, highway or other installation that could be damaged by material being thrown into the air, the blast shall be covered with an adequate blasting mat.

**3303.1.12 Disposal of packaging.** Empty boxes and paper, plastic or fiber packing material which have previously contained explosive materials shall not be reused, and shall be disposed of in accordance with manufacturers recommendations or instructions.

**3303.1.13 Abandonment.** Explosive materials shall not be abandoned.

**3303.2 Transportation.**

**3303.2.1 Public conveyance.** Explosive materials shall not be carried or transported in or upon a public conveyance or vehicle carrying passengers for hire.

Interstate transportation of explosives is not regulated by this code but is covered by the Code of Federal Regulations (CFR) Title 49, Parts 177 and 178 as adopted in IC 8-2-7-43.5. This section shall apply to vehicles transporting blasting agents not covered by IC 8-2-7-43.5 such as intrastate transport.

**3303.2.2 Vehicle construction.** Vehicles used for transporting explosive materials shall be strong enough to carry the load without difficulty and shall be in good mechanical condition. If vehicles do not have a closed body, a portable, magazine-type container that is reasonably weather and theft resistant, and securely fastened to the vehicle body,

shall be used to contain the explosive materials. Vehicles used for the transportation of explosive materials shall have tight floors and any exposed, spark-producing metal on the inside of the body shall be covered with wood or other nonsparking material to prevent contact with explosive materials.

**EXCEPTION:** Exposed spark-producing metal need not be covered in vehicles in which only blasting agents (Explosives, 1.5D—see Appendix VI-F) or oxidizing materials are being transported.

**3303.2.3 Authorization.** Explosive materials shall be transported on vehicles in accordance with section 3303.2.

**3303.2.4 Fire protection.** Vehicles used for transporting explosive materials shall be equipped with fire extinguishers according to the following schedule:

- |   |  |
|---|--|
| <b>1. Vehicle—Gross vehicle weight less than 14,000 pounds (6,350.2 kg).</b>                            | At least two multipurpose dry-chemical extinguishers having a combined capacity of not less than 4-A:20-B:C. |
| <b>2. Vehicle—Gross vehicle weight 14,000 pounds (6,350.2 kg) or greater; tractor/semitrailer units</b> | At least two multipurpose dry-chemical extinguishers having a combined capacity of not less than 4-A:70-B:C. |

**3303.2.5 Fire extinguisher maintenance and placement.** Fire extinguishers shall be securely mounted on vehicles at well-separated, accessible locations. Extinguishers shall be checked monthly to verify that they are filled and in operating condition.

**3303.2.6 Vehicle inspection.** Vehicles used to transport explosive materials shall be inspected by the person to whom a permit has been issued for such vehicles in order to determine that:

1. Electric wires are insulated and securely fastened,
2. The engine chassis and body are reasonably clean and free of excessive grease and oil,
3. The fuel tanks and fuel lines are securely fastened and not leaking,
4. Brakes, lights, horn, windshield wipers and steering mechanism are functioning properly.
5. Tires are properly inflated and free from defects, and
6. The vehicle is in proper condition for transporting explosive materials.

**3303.2.7 Nonsparking tools.** Spark-producing metal tools shall not be carried in the cargo compartment of a vehicle transporting explosive materials.

**3303.2.8 Sources of ignition.** Smoking, carrying matches or other flame-producing devices, carrying firearms or loaded cartridges while in or near a vehicle transporting explosive materials, and driving, loading or unloading any such vehicle in a careless or reckless manner are prohibited.

---

---

## Proposed Rules

---

---

**EXCEPTION:** As allowed by Department of Defense or DOT regulations.

**3303.2.9 Personnel qualifications.** Vehicles transporting explosive materials shall be in the custody of drivers who are physically fit; careful; capable; reliable; able to read and write the English language; not addicted to the use or under the influence of intoxicants, narcotics or DEA-controlled substances; and are not less than 21 years of age. They shall be familiar with federal, state and local traffic regulations, and the provisions of Chapter 33 governing the transportation of explosive materials.

**3303.2.10 Placarding.** Vehicles transporting explosive materials shall display placards, lettering or numbering required by DOT.

**3303.2.11 Detonator identification.** When detonators are transported on the same motor vehicle with other explosive materials, they shall be packaged, labeled, placarded and loaded in accordance with DOT regulations.

**3303.2.12 Transportation routes.** Vehicles transporting explosive materials shall be routed to avoid congested traffic and heavily populated areas.

**3303.2.13 Vehicular tunnels.** Explosive materials shall not be transported through completed vehicular tunnels which prohibit the transport of explosive materials.

**3303.2.14 Unattended vehicles.** Vehicles transporting explosive materials shall not be left unattended.

**3303.2.15 Passengers.** Persons other than the driver and one assistant, who is at least 18 years of age, shall not ride on vehicles transporting explosive materials.

**3303.1.16 Delivery conditions.** Delivery of explosive materials shall be made only to authorized persons and into approved storage, handling or use areas.

**3303.2.17 Vehicle storage and repair.** Vehicles containing explosive materials shall not be taken into a garage or repair shop for repairs or storage.

**3303.3 Explosive Materials Terminals.**

**3303.3.1 Quantities at terminals.** The office of the state fire marshal is authorized to designate the location and specify the maximum quantity of explosive materials allowed to be loaded, unloaded, reloaded or temporarily retained at each terminal where such operations are permitted.

**3303.3.2 Other regulations.** Shipments of explosive materials delivered to carriers shall be in accordance with DOT regulations.

**3303.3.3 Placarding.** Vehicles, while in the terminal, shall

continue to exhibit the placarding required by DOT regulations.

**3303.3.4 Notification.** Carriers shall immediately notify consignees of arrival of explosive materials at terminals.

**3303.3.5 Terminal requirements.** Truck terminals where explosive materials are loaded, unloaded or transferred shall be in accordance with the following conditions:

1. There shall not be aboveground storage tanks of flammable or combustible liquids or other hazardous materials on the terminal property which would present a significant exposure hazard to the operation of the terminal or to adjacent properties.

2. The terminal property shall be sufficiently large that docking or vehicle storage areas containing explosives shall be a minimum of 75 feet (22,860 mm) from adjoining property lines.

3. Explosives shall be kept in vehicles except during transferring or loading operations.

4. Specific areas of docks shall be designated for the holding of explosive materials for not more than 72 hours during loading or transferring operations. A minimum distance shall be specified and maintained between this designated area and other materials on the dock. Combustible storage and flammable and combustible liquids shall be kept the greatest possible distance from this designated area.

5. At all times, a guard shall be on duty on the terminal property. The guard shall be capable of driving all equipment in the area. At times when there are a substantial number of vehicles carrying explosive materials in the terminal, additional persons capable of driving shall be provided.

6. Adequate security against unauthorized persons entering the terminal area shall be provided. In metropolitan areas, this shall include a fence and gates.

7. The terminal shall be adequately lighted for normal observation of all vehicles containing explosive materials.

8. Approved fire-protection appliances shall be provided for the loading dock near the designated explosive materials area and near the parked vehicles.

9. An approved, isolated area of the terminal property shall be designated for vehicles containing explosive materials.

10. Vehicles containing special inherent hazards shall be kept separated from the area designated for the parking of explosive materials vehicles.

11. Shipments of explosive materials shall be transported without unnecessary delay. Delays shall not exceed 72 hours.

**3303.4 Blasting Agents.**

**3303.4.1 Transportation and storage.** Blasting agents (Explosives, 1.5-D - see Appendix VI-F) shall be transported

in accordance with DOT regulations and stored in accordance with federal, state and local regulations.

**3303.4.2 Ammonium nitrate storage.** Ammonium nitrate stored at a closer distance to the blasting agent storage area than provided in Section 3303.4.3 shall be calculated in accordance with Appendix VI-F.

**3303.4.3 Intraplant separation.** Minimum intraplant separation distances between mixing units and the ammonium nitrate storage areas and blasting agent storage areas shall be in accordance with Appendix VI-F.

**3303.5 Safety Precautions for Blasting Agents.**

**3303.5.1 Mixing facilities.** Buildings or other facilities used for mixing blasting agents shall be located away from inhabited buildings, passenger railways and public highways in accordance with Appendix VI-F.

**EXCEPTION:** Bulk mixing and delivery equipment for shot service delivery.

**3303.5.2 Production quantities.** Not more than eight hours' production of blasting agents or the limit determined by nationally recognized standards (see Appendix VI-F), whichever is less, shall be located in or near the building used for mixing blasting agents. Larger quantities shall be stored in magazines.

**3303.5.3 Construction.** Buildings or other facilities used for the mixing of blasting agents shall be designed and constructed in accordance with the Building Code.

**3303.5.4 Compounding and mixing.** Compounding and mixing of approved formulations of blasting agents shall be conducted in accordance with federal, state and local regulations.

**3303.5.5 Sources of ignition.** Smoking and open flames shall be prohibited in or within 50 feet (15,240 mm) of buildings or facilities used for the mixing of blasting agents.

**3303.5.6 Disposal of oxidizer bags.** Empty oxidizer bags shall be disposed in accordance with manufacturers instructions or recommendations.

## **SECTION 3304 - MANUFACTURING, ASSEMBLING AND TESTING**

**3304.1 General.** Manufacture, assembly, testing and loading of explosives, ammunition, blasting agents (Explosives, Division 1.5—see Appendix VI-F) and fireworks shall be in accordance with Section 3304.

**EXCEPTIONS:** 1. Section 3304 does not apply to the hand loading of small arms ammunition prepared for personal use and not for resale.

2. Section 3304 does not apply to the mixing and loading of blasting agents (Explosives; Division 1.5—see Appendix VI-F) at blasting sites provided all necessary safety precautions are taken.

**3304.2 Required Information.**

**3304.2.1 General.** Prior to manufacturing, assembling, testing or loading explosives, ammunition, blasting agents (Explosives; Division 1.5—see Appendix VI-F) or fireworks, the chief shall be furnished with the following information:

1. The exact location of the place of manufacture.
2. The kind of explosives, ammunition, blasting agents (Explosives, Division 1.5—see Appendix VI-F) or fireworks to be manufactured or processed and the property of hazardous materials to be used.
3. The names and addresses of individual owners, partners or officers of the corporation.
4. A plot plan of the operating premises with the operating buildings indicated in which greater than 1 pound (0.45 kg) of explosives is manufactured, handled, used or stored. The maximum amount of explosives greater than 1 pound (0.45 kg) to be used in each building, number of persons in each operating building, barricade locations and dimensions, and the location and capacity of storage magazines.
5. A copy of the general safety rules which the manufacturer will enforce, including plans for emergency procedures in the event of fire or explosion.

**3304.2.2 Retention of plans.** A copy of the plans of the plant shall be kept in the office on the premises of each explosive, ammunition, blasting agents (Explosives, Division 1.5—see Appendix VI-F) or fireworks manufacturing plant and shall be made available to the chief upon request.

**3304.3 Training.** Workers who handle explosives or explosive charges or dispose of explosives shall be trained in the hazards of the materials and processes in which they are to be engaged and in the safety rules governing such materials and processes.

**3304.4 Emergency Procedures.** Approved emergency procedures shall be developed for each plant. Such procedures shall include personal instruction in any emergency that could be anticipated. Personnel shall be made aware of an emergency warning signal.

**3304.5 Intraplant Separation of Operating Buildings.** Mass detonating explosives and fireworks manufacturing buildings, including those where explosive charges are assembled, manufactured, prepared or loaded, shall be separated from all other buildings, including magazines, within the confines of the manufacturing plant by a distance not less than those shown in Table 3304.5-A.

## Proposed Rules

**TABLE 3304.5-A - MINIMUM INTRAPLANT SEPARATION BETWEEN OPERATING BUILDINGS CONTAINING MASS-DETONATING EXPLOSIVES OR FIREWORKS MANUFACTURING <sup>1</sup>**

EXPLOSIVE OR FIREWORKS (pounds) x 0.454 for kg		MINIMUM DISTANCE (feet)	EXPLOSIVE OR FIREWORKS (pounds) x 0.454 for kg		MINIMUM DISTANCE (feet)
Over	Not Over	x 304.8 for mm	Over	Not Over	x 304.8 for mm
	50	60	20,000	25,000	530
50	100	80	25,000	30,000	560
100	200	100	30,000	35,000	590
200	300	120	35,000	40,000	620
300	400	130	40,000	45,000	640
400	500	140	45,000	50,000	660
500	600	150	50,000	55,000	680
600	700	160	55,000	60,000	700
700	800	170	60,000	65,000	720
800	900	180	65,000	70,000	740
900	1,000	190	70,000	75,000	770
1,000	1,500	210	75,000	80,000	780
1,500	2,000	230	80,000	85,000	790
2,000	3,000	260	85,000	90,000	800
3,000	4,000	280	90,000	95,000	820
4,000	5,000	300	95,000	100,000	830
5,000	6,000	320	100,000	125,000	900
6,000	7,000	340	125,000	150,000	950
7,000	8,000	360	150,000	175,000	1,000
8,000	9,000	380	175,000	200,000	1,050
9,000	10,000	400	200,000	225,000	1,100
10,000	15,000	450	225,000	250,000	1,150
15,000	20,000	490			

<sup>1</sup>When a building containing explosives is provided with barricades, the intraline distances shown are allowed to be reduced by one half.

### 3304.6 Buildings and Equipment

**3304.6.1 Construction.** Operating buildings or rooms which exceed the exempt amounts of explosives specified in the Building Code shall be constructed in accordance with the Building Code.

**3304.6.2 Explosive dust.** Explosive dust shall not be exhausted to the atmosphere.

When collecting explosive dust, a “wet” collector system shall be used. Wetting agents shall be compatible with the explosives.

Explosive dusts shall be removed from the collection chamber as often as necessary to prevent overloading. The entire system shall be cleaned at a frequency that will eliminate hazardous concentrations of explosive dusts in pipes, tubing or ducts.

**3304.6.3 Intrinsically safe ventilation system.** Squirrel cage blowers shall not be used for exhausting hazardous fumes, vapors or gases. Nonferrous fan blades shall be used for fans located within the ductwork and through which hazardous materials are exhausted. Motors shall be located outside the duct.

**3304.6.4 Workstation protection.** Workstations shall be separated by distance, barrier or other approved alternates so that fire in one station will not ignite material in the next workstation. When necessary, each operator shall be protected by a personnel shield located between the operator and the explosive device or explosive material being processed. This shield and its support shall be a tested design to withstand a blast from the maximum amount of explosives allowed behind it.

### 3304.7 Operations.

**3304.7.1 Remote processing.** When the type of material and

processing warrants, mechanical operations involving explosives in excess of 1 pound (0.45 kg) shall be performed at isolated stations or at intraplant distances, and machinery shall be controlled from remote locations behind substantial barricades or at separations so that workers can remain at a safe distance while machinery is operating.

**3304.7.2 Static control.** The working area where the screening, grinding, blending and other processing of static-sensitive explosives or pyrotechnic materials are done shall be provided with approved static controls.

**3304.7.3 Explosive containers.** Bulk explosives shall be kept in approved nonsparking containers when not being used or processed. Explosives shall not be stored or transported in open containers.

**3304.7.4 Allowable quantities.** The quantity of explosives at a workstation shall not exceed the quantity posted on the load limit signs established by the intraplant distances. See Table 3304.5-A.

**3304.7.5 Waste receptacles.** Approved receptacles with covers shall be provided for each location for disposing of waste material and debris. These waste receptacles shall be emptied and cleaned as often as necessary but not less than once each day or at the end of each shift.

**3304.7.6 Posting of pertinent information.** General safety rules and operating instructions governing the particular operation or process carried on at that location shall be available at each location.

**3304.7.7 Posted limits.** Personnel and explosive limits shall be posted.

**3304.7.8 Maintenance.** Regular maintenance and repair work shall not be performed in an explosive area until explosives are removed and the area is made safe.

**EXCEPTION:** Minor adjustments or emergency repairs to secure immediate safety.

**3304.7.9 Spills.** Spilled or dropped explosives shall be cleaned up at once.

**3304.7.10 Contaminated materials.** Shipping containers, cleaning rags and other materials contaminated with explosives shall be removed daily and disposed in an approved, safe manner.

**3304.7.11 Storage.** Fireworks, explosives and explosive charges shall not be stored near sources of heat.

**EXCEPTION:** Approved curing or drying operation.

**3304.8 Explosive Materials Testing Sites.**

**3304.8.1 Location.** Detonation of explosive materials or ignition of fireworks for testing purposes shall be performed only in isolated areas at special sites where distance; protection from missiles, shrapnel or flyrock by barricades, bunkers or adequate shelter; and other safeguards to assure adequate protection to prevent injury to personnel or damage to property are provided. See Section 3304.9.

**3304.8.2 Personal protective equipment.** Protective clothing and equipment shall be provided to protect persons engaged in the testing, ignition or detonation of explosive materials.

**3304.8.3 Test site safeguards.** When tests are being conducted or explosives are being detonated, only authorized persons shall be present. Areas where explosives are regularly or frequently detonated or burned shall be fenced and posted with adequate warning signs. Adequate warning devices shall be used before burning or detonating explosives to warn persons who might approach from any direction that they are approaching a danger zone.

**3304.9 Disposal of Waste Explosive Materials.**

**3304.9.1 Disposal site safeguards.** Sites for the destruction of explosive materials and fireworks shall be located in accordance with Appendix VI-F. When possible, barricades shall be utilized between the destruction site and inhabited buildings.

**3304.9.2 Reuse of site.** Unless an approved burning site has been thoroughly saturated with water and has passed a safety inspection, 48 hours shall elapse between the completion of a burn and the placement of scrap explosive materials for a subsequent burn.

**3304.9.3 Personnel safeguards.** Once an explosive burn operation has started, personnel shall relocate to a safe location where adequate protection from air blast and flying debris is provided. Personnel shall not return to the burn area until the person in charge has inspected the burn site and determined that it is safe for personnel to return.

**3304.9.4 Standby personnel.** When required by the chief, standby personnel shall be provided until such time as the site is determined to be safe. See Section 2416.

## **SECTION 3305 - FIREWORKS AND PYROTECHNIC SPECIAL EFFECTS MATERIAL- GENERAL**

**3305.1 Scope.** Fireworks and temporary storage, use and handling of pyrotechnic special effects material used in motion pictures, television, and theatrical and group entertainment productions shall be in accordance with Chapter 33 and IC 22-11-14.

## Proposed Rules

3305.2 Permits.

3305.3 Fireworks.

**3305.3.1 Manufacturing.** It is unlawful for any manufacturer, wholesaler, importer, or distributor to sell at wholesale, or offer to sell at wholesale, or ship or cause to be shipped into Indiana, fireworks, novelties, or trick noisemakers unless he has been issued and holds a valid certificate of compliance issued by the State Fire Marshal. A retailer selling fireworks must apply for a fireworks stand retail sales permit from the State Fire Marshal prior to June 1 of each year.

**3305.3.2 Displays.** See IC 22-11-14 and IC 22-11-14-3.

### SECTION 3306 - FIREWORKS

**3306.1 General.** Storage, use and handling of fireworks shall be in accordance with Section 3306, Indiana Building Code and IC 22-11-14.

- EXCEPTIONS:**
1. The use of fireworks by railroads or other transportation agencies for signaling or illumination.
  2. The sale or use of blank cartridges for theatrics, signaling or ceremonial purposes.
  3. The use of fireworks by the United States Armed Forces.

**3306.2 Seizure of Fireworks.** The office of the state fire marshal is authorized to seize, take, remove or cause to be removed at the expense of the owner all stocks of fireworks offered or exposed for sale, stored or held in violation of Chapter 33 and IC 22-11-14.

**TABLE 3306.3-A - MINIMUM MORTAR SEPARATION DISTANCES**

MORTAR DIAMETER (inches)	MINIMUM SEPARATION FROM SPECTATOR VIEWING AREAS, VEHICLES AND BUILDINGS (feet)
x 25.4 for mm	x 0.3048 for m
less than 3	140
3	210
4	280
5	350
6	420
7	490
8	560
10	700
12	840
greater than 12	980

3306.4 Displays.

**3306.4.1 General.** Fireworks displays shall be in accordance with Section 3306.4.

**3306.4.2 Insurance.** The governing body of the municipality shall require a certificate of insurance in accordance with IC 22-11-14-3.

**3306.4.3 Mortars for aerial shell displays.**

**3306.4.3.1 Site criteria.** Mortars for aerial displays shall be separated from spectator viewing areas, vehicles and buildings as set forth in Table 3306.3-A.

The designated landing area shall be an approved large, clear, open area. Spectators, vehicles and combustible materials shall not be allowed within the designated landing area. The designated landing area shall not be within 100 feet (30,480 mm) of tents, canopies and membrane structures.

**3306.4.3.2 Construction.** Mortars shall be approved for use with the aerial shells to be fired. Mortars shall be constructed of heavy cardboard, paper or metal other than cast iron.

**3306.4.3.3 Inspection.** Prior to placement, mortars shall be inspected for defects such as dents, bent ends, damaged interiors and damaged plugs. Mortars found to be defective shall not be used.

**3306.4.3.4 Positioning.** Mortars shall be positioned so that aerial shells are directed over the designated landing area and away from ground pieces. Mortars shall not be angled toward spectator viewing areas.

The trajectory of aerial shells shall be arranged such that a minimum clearance of 25 feet (7,620 mm) is maintained from potential obstructions.

Seamed metal mortars shall be placed such that the seam of a mortar faces to the side rather than to the top or bottom.

**3306.4.3.5 Securing.** Mortars shall be buried to a depth of not less than two thirds of their length, either in the ground or in aboveground troughs or drums. In soft ground, wood not less than 2 inches (50.8 mm) nominal thickness or rock slabs shall be placed beneath mortars which will be used more than once to prevent their sinking or being driven into the ground during firing.

**EXCEPTION:** Approved securely positioned mortar racks are allowed for the firing of single-break shells 6 inches (152.4 mm) or less in diameter.

**3306.4.3.6 Mortar separation.** Mortars that are buried in the ground, in troughs or in drums shall be separated from adjacent mortars by a distance equal to or greater than the diameter of the mortar.

**EXCEPTION:** Electrically fired mortars.

**3306.4.3.7 Moisture protection.** In damp ground, a weather-resistant bag shall be placed under the bottoms of mortars prior to placement in the ground to protect mortars from moisture. Weather-resistant bags shall be placed over the open end of mortars in damp weather to keep moisture from accumulating on the inside surface of mortars.

**3306.4.3.8 Ground burst protection.** Sand bags, dirt boxes or other suitable protection shall be placed around mortars on the uprange side to protect the operator from ground bursts.

**3306.4.3.9 Paper mortars.**

**3306.4.3.9.1 Convolute.** Paper mortars constructed of convolute wound paper shall be approved for the size aerial shells being discharged having a maximum double break.

**3306.4.3.9.2 Spiral wound.** Spiral-wound paper mortars shall not be used for greater than 3 inch (76.2 mm) diameter aerial shells with a maximum double break.

**3306.4.3.10 Grouping mortars.** Mortars of the same diameter, which are to be reloaded during a display, shall be grouped together such that various sized are not intermixed. Groups shall be separated.

**3306.4.3.11 Loose gravel and rocks.** Loose gravel, rocks and other loose solid objects shall be removed from the area around mortars to prevent such materials from being thrown from ground bursts during firing.

**3306.4.3.12 Cleaning tool.** When mortars are to be fired more than once during a display, a cleaning tool shall be available for the cleaning of debris from mortars as necessary. For metal mortars, the tool shall be nonsparking.

**3306.4.4 Ground pieces.**

**3306.4.4.1 Location.** Ground pieces shall be located not less than 150 feet (45,720 mm) from spectators and vehicles; not less than 100 feet (30,480 mm) from tents, canopies or membrane structures; not less than 100 feet (30,480 mm) from mortars; and outside of the designated landing area.

**EXCEPTIONS:** 1. Fixed ground pieces are allowed not less than 75 feet (22,860 mm) from spectators and vehicles.

2. Electrically fired ground pieces are allowed in the designated landing area.

**3306.4.4.2 Combustibles.** The area beneath ground pieces shall be free of dry grass and combustibles.

**3306.4.4.3 Securing.** Poles for ground pieces shall be securely placed and braced.

**3306.4.5 Electrical fire units.**

**3306.4.5.1 General.** Electrical firing units shall be in accordance with Section 3306.4.5.

**3306.4.5.2 Wiring.** Electrical wiring associated with an electrical firing unit shall be prevented from contacting metal objects in contact with the ground.

**3306.4.5.3 Power supply.** AC-powered electrical firing units shall be isolated from the power source using an isolation transformer.

**3306.4.5.4 Security.** Electrical firing units shall require operation of a key-operated switch or other similar device to prevent unauthorized operation.

**EXCEPTION:** Hand-held electrical firing units connected to fireworks only during a display.

**3306.4.5.5 Manually activated firing units.** Manually activated electrical firing units shall require two or more distinct actions to apply electric current to an electric match.

**3306.4.5.6 Automatic-firing units.** Automatic-sequencing-type electrical firing units shall include a momentary contact switch which must be held to cause application of current to an electric match and which will immediately disconnect current to all electric matches upon release.

**3306.4.5.7 Testing of firing circuits.** The pyrotechnic operator shall ensure that personnel are kept at a safe distance from fireworks which are connected to electrical firing units during testing. Electrical firing units with integral test circuits shall be designed to limit the maximum current output during a test to 0.05 ampere or to 20 percent of the no-fire current of electric matches, whichever is less. Multitesters shall not be used for testing unless the maximum current output has been measured and determined not to exceed the current output limits for integral test circuits.

**3306.4.6 Inspection.** Fireworks shall be inspected upon delivery to the display site by the pyrotechnic operator. Aerial shells having tears, leaks or broken fuses or showing signs of having been wet shall be properly disposed of.

**3306.4.7 Supervision.** Fireworks shall not be left unattended or allowed to become wet at the display site.

**3306.4.8 Display operation.**

**3306.4.8.1 General.** Display operation shall be in accordance with Section 3306.4.8.

**3306.4.8.2 Fire protection.** The pyrotechnic operator shall provide portable fire extinguishers for the discharge area and arrange for standby fire apparatus for protection down range.

**3306.4.8.3 Monitors.** The pyrotechnic operator shall employ monitors whose sole duty shall be the enforcement of crowd

---

---

## Proposed Rules

---

---

control around the display area. Unauthorized persons shall not be allowed to enter the discharge site until the site has been inspected after the display by the pyrotechnic operator.

**3306.4.8.4 Barriers.** The chief is authorized to require rope barriers, fences, signs or other devices to be installed around the display area to aid in crowd control.

**3306.4.8.5 Display discontinued.** If the chief or the pyrotechnic operator determines that there is a lack of crowd control or that the crown is in danger, the display shall be immediately discontinued. If at any time high winds or wet weather creates a danger, the display shall be postponed until the weather conditions are acceptable to the chief.

**3306.4.8.6 Illumination.** Display operators shall use only flashlights or electric lighting for illumination.

**3306.4.8.7 Smoking and open flames.** Smoking and use of open flames are prohibited in the aerial shell storage area. **NO SMOKING OR OPEN FLAME** signs shall be conspicuously posted.

**3306.4.8.8 Aerial shells.**

**3306.4.8.8.1 General.** Aerial shell operations shall be in accordance with Section 3306.4.8.8.

**3306.4.8.8.2 Ready boxes.** Ready boxes shall be located not less than 25 feet (7,620 mm) in an upwind direction from mortars.

**3306.4.8.8.3 Transporting.** Aerial shells shall be carried to mortars by the shell body. For the purpose of loading mortars, aerial shells shall be held by the thick portion of the fuse and carefully lowered into mortars.

**3306.4.8.8.4 Proper fit.** Aerial shells shall be checked for proper fit in mortars prior to discharge. The pyrotechnic operator shall inspect all aerial shells to be certain that they are properly seated in mortars prior to firing. Aerial shells that do not fit properly shall not be fired.

**3306.4.8.8.5 Safety cap.** The safety cap protecting a fuse shall not be removed until immediately before an aerial shell is to be fired.

**3306.4.8.8.6 Ignition.** Aerial shells shall be ignited by lighting the tips of fuses with a fuse, torch, portfire, electrical ignition source or similar device. Operators shall not place any part of their bodies over the throat of a mortar.

**3306.4.8.8.7 Trajectory.** The first aerial shell fired shall be carefully observed to determine that its trajectory will carry it into the intended firing range and that the aerial shell will function over and debris will drop into the designated landing area. Mortars shall be reangled or reset if necessary

at any time during the display to properly maintain trajectories over the designated landing area.

**3306.4.8.8.8 Defective aerial shells.** If an aerial shell fails to ignite in a mortar, the mortar shall be left alone for a minimum of 15 minutes, then carefully flooded with water. Immediately following the display, and not less than 5 minutes after flooding the mortar, the mortar shall be emptied into a bucket of water and properly disposed of. Damaged aerial shells shall not be repaired or dismantled.

**3306.4.8.8.9 Range inspection.** The entire firing range shall be inspected immediately following a display and prior to allowing public access for the purpose of locating unexploded aerial shells. Such shells shall not be handled within 15 minutes of their firing. Such shells shall then be doused with water, allowed to stand for not less than 5 minutes and placed in a bucket of water.

When the firing range cannot be thoroughly inspected due to darkness, the site shall be reinspected the following morning.

**3306.4.8.8.10 Record.** The pyrotechnic operator shall keep a record of aerial shells that fail to ignite or fail to function.

### SECTION 3307 - PYROTECHNIC SPECIAL EFFECTS MATERIAL

**3307.1 General.** Temporary storage, use and handling of pyrotechnic special effects material used in motion picture, television, theatrical and group entertainment productions shall be in accordance with Section 3307. Permanent storage of pyrotechnic special effects material shall be in accordance with Chapter 33.

**3307.2 Classification of Materials.** Pyrotechnic special effects material shall be classified in accordance with DOT regulations and procedures. See Appendix VI-F.

**EXCEPTION:** Pyrotechnic special effects material which is manufactured on-site and which is in storage or use need not be classified.

**3307.3 Construction of Magazines.** Magazines used for the storage of pyrotechnic special effects material shall be constructed in accordance with Section 3302.3.

**3307.4 Storage.**

**3307.4.1 Fireworks 1.4G.** Fireworks 1.4G (Class C common fireworks) shall be stored in accordance with the requirements for low explosives in Chapter 33.

**3307.4.2 Other pyrotechnic special effects material.**

**3307.4.2.1 General.** Storage of pyrotechnic special effects material other than fireworks 1.4G (Class C common



fireworks) shall be in accordance with the requirements of Sections 3302 and 3307.4.2.

Containers of explosive materials shall be closed when stored.

#### 3307.4.2.2 Storage magazines.

3307.4.2.2.1 Within buildings. Explosives stored within a building shall not exceed 50 pounds (22.7 kg). Low explosives stored within a building shall be stored in a Type 2 or 4 magazine. High explosives shall be stored in a Type 2 magazine.

Detonators shall be stored in a separate Type 2 magazine.

3307.4.2.2.2 Outside of buildings. Pyrotechnic special effects material which is to be stored outdoors shall be stored in a Type 2 or 4 magazine. Pyrotechnic special effects material which is classified as a high explosive, including detonating cord and detonators that will mass detonate, such as fuse caps, shall be stored in a Type 2 magazine.

When a Type 4 magazine is used for outdoor storage, such storage shall be in a constantly attended location or, if unattended, shall have wheels removed or the magazine immobilized by kingpin locking devices or by other approved security measures. When a quantity in excess of 50 pounds (22.7 kg) of explosive materials is stored outside of a building, such storage shall be located in accordance with Appendix VI-F.

3307.4.3 Storage against walls. Explosive materials within a magazine shall not be placed directly against interior walls and shall not interfere with ventilation. To prevent contact of stored explosive materials with walls, a nonsparking lattice-work or other nonsparking material is allowed to be used.

3307.4.4 Marking of containers. Containers of explosive materials shall be stored such that identifying marks are visible. Stocks of explosive materials shall be stored so they can be easily counted and checked upon inspection.

3307.4.5 Unpacking and repacking containers. Containers of explosive materials shall not be unpacked or repacked inside a magazine or within 50 feet (15,240 mm) of a magazine, and shall not be unpacked or repacked close to other explosive materials.

**EXCEPTION:** Unpacking and repacking of fiberboard and other nonmetallic containers.

3307.4.6 Tools. Tools used for opening or closing containers of explosive materials shall be of nonsparking materials. A wood wedge and a fiber, rubber or wooden mallet shall be used for opening or closing wood containers or explosive

materials. Metal tools, other than nonsparking transfer conveyors, shall not be stored in magazines containing high explosives.

**EXCEPTION:** Metal slitters are allowed to be used for opening fiberboard containers.

3307.5 Smoking and Open Flames. Controls on smoking and open flames shall be in accordance with Sections 3302.1.14, 3303.1.4, and 3303.1.5.

3307.6 Housekeeping. Housekeeping shall be in accordance with Chapter 33.

3307.7 Pyrotechnic Operators. A pyrotechnic operator shall obtain required permits and be responsible for notifying the chief prior to using the pyrotechnic special effects material. The pyrotechnic operator shall have the authority and responsibility for the storage, use and handling of the pyrotechnic special effects materials. The authority of the pyrotechnic operator shall not be assumed by anyone and shall be superseded only by the chief.

#### 3307.8 Use of Pyrotechnic Special Effects Material.

##### 3307.8.1 General precautions.

3307.8.1.1 Demonstration and approval. An approved test shall be conducted to demonstrate the safe use of pyrotechnic special effects material prior to normal use.

The use of pyrotechnic special effects material shall be approved by the pyrotechnic operator in charge.

3307.8.1.2 Preparation. The company or producer shall allocate sufficient time to the pyrotechnic operator to prepare for the transportation, packing, storing and daily securing, and to dispose of or otherwise handle pyrotechnic special effects material in a safe manner.

3307.8.1.3 Crowd control. Onlookers shall be kept at a safe distance from the area where the pyrotechnic special effects material is discharged and so restrained until the area is cleared.

3307.8.2 Smoke control. When pyrotechnic special effects material is fired within a building, the quantity of smoke developed shall not obscure the visibility of exit signs or paths of egress travel.

Provision shall be made to remove smoke from the building that is generated by pyrotechnic special effects material.

3307.8.3 Binary explosives. When binary explosives are used, the compounding and firing shall be performed by a pyrotechnic operator.

## Proposed Rules

**3307.8.4 Surplus materials.** Surplus materials shall be properly stored until it can be disposed of in a safe manner.

**3307.9 Standby Personnel and Equipment.** When necessary for the preservation of life and property, the chief is authorized to require the attendance of standby personnel and fire equipment as set forth in Section 2416. (*Fire Prevention and Building Safety Commission; 675 IAC 22-2.3-285*)

**675 IAC 22-2.3-286 Section 3401.2; nonapplicability**

Authority: IC 22-13-2-2

Affected: IC 22-12-7; IC 22-13; IC 22-14; IC 36-8-17

**Sec. 286.** In Section 3401.2 delete the words “service station and insert “motor fuel dispensing facilities, repair garages.”. (*Fire Prevention and Building Safety Commission; 675 IAC 22-2.3-286*)

**675 IAC 22-2.3-287 Section 3401.4; permits**

Authority: IC 22-13-2-2

Affected: IC 22-12-7; IC 22-13; IC 22-14; IC 36-8-17

**Sec. 287.** Delete Section 3401.4 and substitute to read as follows: **3401.4 Plans.** Prior to commencement of construction to store more than 660 gallons (18,925 L) of liquid outside of buildings in drums or tanks, the owner shall notify the servicing fire department, in writing, of the proposed storage and that a copy of the plans released under 675 IAC 12-6 are available upon request. A copy of the released plans shall indicate the method of storage, quantities to be stored, distances from the buildings and property lines, accessways, fire protection facilities, and provisions for spill control, drainage control and secondary containment. (*Fire Prevention and Building Safety Commission; 675 IAC 22-2.3-287*)

**675 IAC 22-2.3-288 Section 3403.2.1; portable fire extinguishers and hose lines**

Authority: IC 22-13-2-2

Affected: IC 22-12-7; IC 22-13; IC 22-14; IC 36-8-17

**Sec. 288.** Amend Section 3403.2.1 to read as follows: **Portable fire extinguishers shall be provided in accordance with Section 906 and hose lines in accordance with Section 905.** (*Fire Prevention and Building Safety Commission; 675 IAC 22-2.3-288*)

**675 IAC 22-2.3-289 Section 3403.5; labeling and signage**

Authority: IC 22-13-2-2

Affected: IC 22-12-7; IC 22-13; IC 22-14; IC 36-8-17

**Sec. 289.** Change the first sentence of Section 3403.5 to read as follows: **The inspection authority is authorized to require warning signs for the purpose of identifying hazards or storing or using flammable liquids, when such storage or using would cause a fire or explosion hazard.** (*Fire Prevention and Building Safety Commission; 675 IAC 22-2.3-289*)

**675 IAC 22-2.3-290 Section 3404.2.2; use of tank vehicles and tank cars as storage**

Authority: IC 22-13-2-2

Affected: IC 22-12-7; IC 22-13; IC 22-14; IC 36-8-17

**Sec. 290.** Change Section 3404.2.2 to read as follows: **3404.2.2 Use of tank vehicles and tank cars as storage tanks. Tank cars and tank vehicles shall not be used as permanent storage tanks.** (*Fire Prevention and Building Safety Commission; 675 IAC 22-2.3-290*)

**675 IAC 22-2.3-291 Section 3404.2.3.1; smoking and open flame**

Authority: IC 22-13-2-2

Affected: IC 22-12-7; IC 22-13; IC 22-14; IC 36-8-17

**Sec. 291.** Add EXCEPTIONS to Section 3404.2.3.1 to read as follows:

**EXCEPTIONS:** 1. Buildings or structures which are smoke-free environments and are posted as such at all public and employee entrances, and  
2. No visible evidence of prohibited smoking exist within the building or structure.

(*Fire Prevention and Building Safety Commission; 675 IAC 22-2.3-291*)

**675 IAC 22-2.3-292 Section 3404.2.7.5.5.2; underground tanks**

Authority: IC 22-13-2-2

Affected: IC 22-12-7; IC 22-13; IC 22-14; IC 36-8-17

**Sec. 292.** In Section 3404.2.7.5.5.2, delete “1,000 gallons (3,785 L)” and substitute “1,100 gallons (3,822.85 L)”. (*Fire Prevention and Building Safety Commission; 675 IAC 22-2.3-292*)

**675 IAC 22-2.3-293 Section 3404.2.7.5.8; overfill prevention**

Authority: IC 22-13-2-2

Affected: IC 22-12-7; IC 22-13; IC 22-14; IC 36-8-17

**Sec. 293.** In Section 3404.2.7.5.8, add “underground” after “liquid” and before “storage”. (*Fire Prevention and Building Safety Commission; 675 IAC 22-2.3-293*)

**675 IAC 22-2.3-294 Section 3404.2.7.11; tank lining**

Authority: IC 22-13-2-2

Affected: IC 22-12-7; IC 22-13; IC 22-14; IC 36-8-17

**Sec. 294.** Change Section 3404.2.7.11 to read as follows: **3404.2.7.11 Tank lining.** Steel tanks may be lined for the purpose of protecting the interior from corrosion or providing compatibility with a material to be stored. Only those liquids tested for compatibility with the lining material are allowed to be stored in lined tanks. (*Fire Prevention and Building Safety Commission; 675 IAC 22-2.3-294*)

**675 IAC 22-2.3-295 Section 3404.2.8.6; vehicle impact protection**

Authority: IC 22-13-2-2

Affected: IC 22-12-7; IC 22-13; IC 22-14; IC 36-8-17

**Sec. 295.** In Section 3404.2.8.6, change “Section 313” to “Section 312”. (*Fire Prevention and Building Safety Commission; 675 IAC 22-2.3-295*)

**675 IAC 22-2.3-296 Section 3404.2.10; drainage and diking**

Authority: IC 22-13-2-2  
Affected: IC 22-12-7; IC 22-13; IC 22-14; IC 36-8-17

**Sec. 296.** In Section 3404.2.10, delete both EXCEPTIONS and substitute to read as follows:

- EXCEPTIONS:** 1. Aboveground tanks are not required to be provided with diking when the tank complies with the requirements of Section 2206.2.3 Installation of Tanks, including subsections (a), (b), and (c), and secondary containment systems are monitored for leak detection with an automatic alarm system, visual and/or audible.
2. Approved aboveground tanks with a capacity of five hundred (500) gallons or less, utilized solely for the storage of used motor oil, and in compliance with EPA 40 CFR 279.22 and EPA 40 CFR 264.175 are exempt from the requirements of 3404.2.10.
3. Drainage control and diking is not required for listed secondary containment tanks.

(*Fire Prevention and Building Safety Commission; 675 IAC 22-2.3-296*)

**675 IAC 22-2.3-297 Section 3404.2.10.5; equipment, controls and pipign in diked areas**

Authority: IC 22-13-2-2  
Affected: IC 22-12-7; IC 22-13; IC 22-14; IC 36-8-17

**Sec. 297.** In Section 3404.2.10.5, add EXCEPTION 3 to read as follows: EXCEPTION 3. Tanks storing more than 5,000 gallons of gasoline, diesel fuel or kerosene may have pumps and manifolds attached directly to the tank within diked areas. (*Fire Prevention and Building Safety Commission; 675 IAC 22-2.3-297*)

**675 IAC 22-2.3-298 Section 3404.2.11.4; overfill protection and prevention system**

Authority: IC 22-13-2-2  
Affected: IC 22-12-7; IC 22-13; IC 22-14; IC 36-8-17

**Sec. 298.** Delete the text of Section 3404.2.11.4 and substitute to read as follows: 3404.2.11.4 Overfill protection and prevention systems. Fillpipes shall be equipped with a spill container and an overfill prevention system for each tank. The system shall either:

- (1) Automatically shut off the flow of liquid into the tank when the tank is not more than 95 percent of tank capacity; or
- (2) Have an alarm which provides an audible and visual signal when the quantity of liquid in the tank reaches 90 percent of the tank capacity; or
- (3) Restrict flow thirty (30) minutes prior to overfilling,

and alert the transfer operator with a high level alarm one minute before overfilling or automatically shut off flow into the tank so that none of the fittings located on the top of the tank are exposed to product due to overfilling.

(*Fire Prevention and Building Safety Commission; 675 IAC 22-2.3-298*)

**675 IAC 22-2.3-299 Section 3404.3.1.1; approved containers**

Authority: IC 22-13-2-2  
Affected: IC 22-12-7; IC 22-13; IC 22-14; IC 36-8-17

**Sec. 299.** Change the text of Section 3404.3.1.1 to read as follows: Only listed or labeled containers and portable tanks shall be used. (*Fire Prevention and Building Safety Commission; 675 IAC 22-2.3-299*)

**675 IAC 22-2.3-300 Section 3404.3.3.9; idle combustible pallets**

Authority: IC 22-13-2-2  
Affected: IC 22-12-7; IC 22-13; IC 22-14; IC 36-8-17

**Sec. 300.** In Section 3404.3.3.9, delete “NFPA 231” and substitute “NFPA 13 (675 IAC 13-1)”. (*Fire Prevention and Building Safety Commission; 675 IAC 22-2.3-300*)

**675 IAC 22-2.3-301 Section 3404.3.6.5; storage plan**

Authority: IC 22-13-2-2  
Affected: IC 22-12-7; IC 22-13; IC 22-14; IC 36-8-17

**Sec. 301.** In Section 3404.3.6.5, delete “when required by the code official”. (*Fire Prevention and Building Safety Commission; 675 IAC 22-2.3-301*)

**675 IAC 22-2.3-302 Section 3404.3.8.4; fire-extinguishing systems**

Authority: IC 22-13-2-2  
Affected: IC 22-12-7; IC 22-13; IC 22-14; IC 36-8-17

**Sec. 302.** In Section 3404.3.8.4, delete “and NFPA 231C”. (*Fire Prevention and Building Safety Commission; 675 IAC 22-2.3-302*)

**675 IAC 22-2.3-303 Section 3404.3.8.5; warehouse hose line**

Authority: IC 22-13-2-2  
Affected: IC 22-12-7; IC 22-13; IC 22-14; IC 36-8-17

**Sec. 303.** Amend Section 3404.3.8.5 by deleting “Chapter 9” and inserting “Section 905”. (*Fire Prevention and Building Safety Commission; 675 IAC 22-2.3-303*)

**675 IAC 22-2.3-304 Section 3405.3.1; closing of mixing or blending vessels**

Authority: IC 22-13-2-2  
Affected: IC 22-12-7; IC 22-13; IC 22-14; IC 36-8-17

**Sec. 304.** In Section 3405.3.1, delete the EXCEPTION without substitution. (*Fire Prevention and Building Safety Commission; 675 IAC 22-2.3-304*)

## Proposed Rules

### 675 IAC 22-2.3-305 Section 3405.3.7.5.1; ventilation

Authority: IC 22-13-2-2

Affected: IC 22-12-7; IC 22-13; IC 22-14; IC 36-8-17

**Sec. 305.** In Section 3405.3.7.5.1, delete the **EXCEPTION without substitution.** (*Fire Prevention and Building Safety Commission; 675 IAC 22-2.3-305*)

### 675 IAC 22-2.3-306 Section 3405.3.8; use, dispensing and handling outside of buildings

Authority: IC 22-13-2-2

Affected: IC 22-12-7; IC 22-13; IC 22-14; IC 36-8-17

**Sec. 306.** In Section 3405.3.8, delete “service station and insert “motor fuel dispensing facilities”. (*Fire Prevention and Building Safety Commission; 675 IAC 22-2.3-306*)

### 675 IAC 22-2.3-307 Section 3406.2.2; marking of tanks and containers

Authority: IC 22-13-2-2

Affected: IC 22-12-7; IC 22-13; IC 22-14; IC 36-8-17

**Sec. 307.** Delete the last sentence of Section 3406.2.2 without substitution. (*Fire Prevention and Building Safety Commission; 675 IAC 22-2.3-307*)

### 675 IAC 22-2.3-308 Section 3406.2.4.3; location

Authority: IC 22-13-2-2

Affected: IC 22-12-7; IC 22-13; IC 22-14; IC 36-8-17

**Sec. 308.** In Section 3406.2.4.3, change “50 feet (15,240 mm)” to “10 feet (3,048 mm)” in two (2) places. (*Fire Prevention and Building Safety Commission; 675 IAC 22-2.3-308*)

### 675 IAC 22-2.3-309 Section 3406.2.8; dispensing from tank vehicles

Authority: IC 22-13-2-2

Affected: IC 22-12-7; IC 22-13; IC 22-14; IC 36-8-17

**Sec. 309.** In Section 3406.2.8, change EXCEPTION 1 to read as follows: **The tank vehicle is equipped to supply fuel to motor vehicle fuel tanks.** (*Fire Prevention and Building Safety Commission; 675 IAC 22-2.3-309*)

### 675 IAC 22-2.3-310 Section 3406.2.8.1; location

Authority: IC 22-13-2-2

Affected: IC 22-12-7; IC 22-13; IC 22-14; IC 36-8-17

**Sec. 310.** In Section 3406.2.8.1, change “50 feet (15,240 mm)” to “25 feet (7,620 mm)”. (*Fire Prevention and Building Safety Commission; 675 IAC 22-2.3-310*)

### 675 IAC 22-2.3-311 Section 3406.4; bulk plants or terminals

Authority: IC 22-13-2-2

Affected: IC 22-12-7; IC 22-13; IC 22-14; IC 36-8-17

**Sec. 311.** In Section 3406.4, add a sentence at the end to read as follows: “Also see Section 2206.2.3.1 of this code.” (*Fire Prevention and Building Safety Commission; 675 IAC 22-2.3-311*)

### 675 IAC 22-2.3-312 Section 3406.4.7; wharves

Authority: IC 22-13-2-2

Affected: IC 22-12-7; IC 22-13; IC 22-14; IC 36-8-17

**Sec. 312.** Amend Section 3406.4.7 by deleting “service stations” and inserting “motor fuel dispensing facilities”. (*Fire Prevention and Building Safety Commission; 675 IAC 22-2.3-312*)

### 675 IAC 22-2.3-313 Section 3406.5; bulk transfer and process transfer operations

Authority: IC 22-13-2-2

Affected: IC 22-12-7; IC 22-13; IC 22-14; IC 36-8-17

**Sec. 313.** Amend Section 3406 by deleting “service station” and inserting “motor fuel dispensing facilities”. (*Fire Prevention and Building Safety Commission; 675 IAC 22-2.3-313*)

### 675 IAC 22-2.3-314 Section 3406.5.1.18; security

Authority: IC 22-13-2-2

Affected: IC 22-12-7; IC 22-13; IC 22-14; IC 36-8-17

**Sec. 314.** Amend Section 3406.5.1.18 as follows:

(1) Delete “vehicle service station” and insert “fuel dispensing facilities”.

(2) Delete EXCEPTION 2 without substitution and renumber EXCEPTION 3 as EXCEPTION 2.

(*Fire Prevention and Building Safety Commission; 675 IAC 22-2.3-314*)

### 675 IAC 22-2.3-315 Section 3406.5.4.4; fueling of vehicles at farms, construction sites and similar areas

Authority: IC 22-13-2-2

Affected: IC 22-12-7; IC 22-13; IC 22-14; IC 36-8-17

**Sec. 315.** Change Section 3406.5.4.4 to read as follows: **3406.5.4.4 Fueling of vehicles at construction sites and similar areas.** Transfer of liquid from tank vehicles to motor vehicles at construction sites, earth-moving projects, gravel pits and borrow pits is allowed in accordance with Section 3406.2.8. (*Fire Prevention and Building Safety Commission; 675 IAC 22-2.3-315*)

### 675 IAC 22-2.3-316 Section 3406.8; vapor recovery and vapor-processing systems

Authority: IC 22-13-2-2

Affected: IC 22-12-7; IC 22-13; IC 22-14; IC 36-8-17

**Sec. 316.** Amend Section 3406.8, EXCEPTION 2, by

deleting “service station” and inserting “motor fuel dispensing facility”. (*Fire Prevention and Building Safety Commission; 675 IAC 22-2.3-316*)

**675 IAC 22-2.3-317 Section 3501.2; permits**

Authority: IC 22-13-2-2  
Affected: IC 22-12-7; IC 22-13; IC 22-14; IC 36-8-17

**Sec. 317. Delete Section 3501.2 without substitution.** (*Fire Prevention and Building Safety Commission; 675 IAC 22-2.3-317*)

**675 IAC 22-2.3-318 Section 3601.2; permits**

Authority: IC 22-13-2-2  
Affected: IC 22-12-7; IC 22-13; IC 22-14; IC 36-8-17

**Sec. 318. Delete Section 3601.2 without substitution.** (*Fire Prevention and Building Safety Commission; 675 IAC 22-2.3-318*)

**675 IAC 22-2.3-319 Section 3606.5.5; electrical equipment**

Authority: IC 22-13-2-2  
Affected: IC 22-12-7; IC 22-13; IC 22-14; IC 36-8-17

**Sec. 319. In Section 3606.5.5, delete “shall be approved types and shall be approved” and substitute “shall be listed”.** (*Fire Prevention and Building Safety Commission; 675 IAC 22-2.3-319*)

**675 IAC 22-2.3-320 Section 3701.2; permits**

Authority: IC 22-13-2-2  
Affected: IC 22-12-7; IC 22-13; IC 22-14; IC 36-8-17

**Sec. 320. Delete Section 3701.2 without substitution.** (*Fire Prevention and Building Safety Commission; 675 IAC 22-2.3-320*)

**675 IAC 22-2.3-321 Section 3704.2.2.7; treatment systems**

Authority: IC 22-13-2-2  
Affected: IC 22-12-7; IC 22-13; IC 22-14; IC 36-8-17

**Sec. 321. Amend Section 3704.2.2.7 as follows: In EXCEPTION 2 Toxic gases-use, add “or portable tanks” after “cylinders”.** (*Fire Prevention and Building Safety Commission; 675 IAC 22-2.3-321*)

**675 IAC 22-2.3-322 Section 3801.2; permits**

Authority: IC 22-13-2-2  
Affected: IC 22-12-7; IC 22-13; IC 22-14; IC 36-8-17

**Sec. 322. Delete Section 3801.2 without substitution.** (*Fire Prevention and Building Safety Commission; 675 IAC 22-2.3-322*)

**675 IAC 22-2.3-323 Section 3801.3; construction documents**

Authority: IC 22-13-2-2  
Affected: IC 22-12-7; IC 22-13; IC 22-14; IC 36-8-17

**Sec. 323. At the end of Section 3801.3, insert “in accordance with the General Administrative Rules (675 IAC 12)”.** (*Fire Prevention and Building Safety Commission; 675 IAC 22-2.3-323*)

**675 IAC 22-2.3-324 Section 3801.4; records**

Authority: IC 22-13-2-2  
Affected: IC 22-12-7; IC 22-13; IC 22-14; IC 36-8-17

**Sec. 324. Delete Section 3801.4 without substitution.** (*Fire Prevention and Building Safety Commission; 675 IAC 22-2.3-324*)

**675 IAC 22-2.3-325 Section 3803.2.1.2; construction and temporary heating**

Authority: IC 22-13-2-2  
Affected: IC 22-12-7; IC 22-13; IC 22-14; IC 36-8-17

**Sec. 325. In Section 3803.2.1.2, after “portable” and before “containers”, insert “LP gas”.** (*Fire Prevention and Building Safety Commission; 675 IAC 22-2.3-325*)

**675 IAC 22-2.3-326 Section 3804.1; general**

Authority: IC 22-13-2-2  
Affected: IC 22-12-7; IC 22-13; IC 22-14; IC 36-8-17

**Sec. 326. In Section 3804.1, delete “and be subject to the approval of the code official”.** (*Fire Prevention and Building Safety Commission; 675 IAC 22-2.3-326*)

**675 IAC 22-2.3-327 Section 3804.2; maximum capacity within established limits**

Authority: IC 22-13-2-2  
Affected: IC 22-12-7; IC 22-13; IC 22-14; IC 36-8-17

**Sec. 327. Delete the Exception in Section 3804.2.** (*Fire Prevention and Building Safety Commission; 675 IAC 22-2.3-327*)

**675 IAC 22-2.3-328 Section 3805.2; release to atmosphere**

Authority: IC 22-13-2-2  
Affected: IC 22-12-7; IC 22-13; IC 22-14; IC 36-8-17

**Sec. 328. In Section 3805.2, delete the text after “except” and substitute “as provided by NFPA 58”.** (*Fire Prevention and Building Safety Commission; 675 IAC 22-2.3-328*)

**675 IAC 22-2.3-329 Section 3806.1; attendants**

Authority: IC 22-13-2-2  
Affected: IC 22-12-7; IC 22-13; IC 22-14; IC 36-8-17

**Sec. 329. In Section 3806.1, delete “a qualified attendant” and substitute “qualified personnel”.** (*Fire Prevention and Building Safety Commission; 675 IAC 22-2.3-329*)

**675 IAC 22-2.3-330 Section 3807.2; smoking and other sources of ignition**

Authority: IC 22-13-2-2  
Affected: IC 22-12-7; IC 22-13; IC 22-14; IC 36-8-17

## Proposed Rules

**Sec. 330.** Change Section 3807.2 to read as follows: NO SMOKING signs complying with Section 310 shall be posted. Smoking within 25 feet (7,625 mm) of a point of transfer, while filling operations are in progress at containers or vehicles, shall be prohibited. Control of other sources of ignition shall comply with NFPA 58. (Fire Prevention and Building Safety Commission; 675 IAC 22-2.3-330)

**675 IAC 22-2.3-331** Section 3809.7; storage in basement, pit or similar location

Authority: IC 22-13-2-2  
Affected: IC 22-12-7; IC 22-13; IC 22-14; IC 36-8-17

**Sec. 331.** In Section 3809.7, after "underfloor" and before "spaces", add "crawl". (Fire Prevention and Building Safety Commission; 675 IAC 22-2.3-331)

**675 IAC 22-2.3-332** Section 3809.12; location of storage outside of buildings

Authority: IC 22-13-2-2  
Affected: IC 22-12-7; IC 22-13; IC 22-14; IC 36-8-17

**Sec. 332.** Delete Section 3809.12 and substitute to read as follows: Storage outside of buildings, for containers awaiting use, resale or part of a cylinder exchange program, shall be located and protected in accordance with NFPA 58. (Fire Prevention and Building Safety Commission; 675 IAC 22-2.3-332)

**675 IAC 22-2.3-333** Section 3901.2; permits

Authority: IC 22-13-2-2  
Affected: IC 22-12-7; IC 22-13; IC 22-14; IC 36-8-17

**Sec. 333.** Delete 3901.2 without substitution. (Fire Prevention and Building Safety Commission; 675 IAC 22-2.3-333)

**675 IAC 22-2.3-334** Section 4001.2; permits

Authority: IC 22-13-2-2  
Affected: IC 22-12-7; IC 22-13; IC 22-14; IC 36-8-17

**Sec. 334.** Delete Section 4001.2 without substitution. (Fire Prevention and Building Safety Commission; 675 IAC 22-2.3-334)

**675 IAC 22-2.3-335** Section 4101.2; permits

Authority: IC 22-13-2-2  
Affected: IC 22-12-7; IC 22-13; IC 22-14; IC 36-8-17

**Sec. 335.** Delete 4101.2 without substitution. (Fire Prevention and Building Safety Commission; 675 IAC 22-2.3-335)

**675 IAC 22-2.3-336** Section 4201.2; permits

Authority: IC 22-13-2-2  
Affected: IC 22-12-7; IC 22-13; IC 22-14; IC 36-8-17

**Sec. 336.** Delete Section 4201.2 without substitution. (Fire Prevention and Building Safety Commission; 675 IAC 22-2.3-336)

**675 IAC 22-2.3-337** Section 4301.2; permits

Authority: IC 22-13-2-2  
Affected: IC 22-12-7; IC 22-13; IC 22-14; IC 36-8-17

**Sec. 337.** Delete Section 4301.2 without substitution. (Fire Prevention and Building Safety Commission; 675 IAC 22-2.3-337)

**675 IAC 22-2.3-338** Section 4401.2; permits

Authority: IC 22-13-2-2  
Affected: IC 22-12-7; IC 22-13; IC 22-14; IC 36-8-17

**Sec. 338.** Delete Section 4401.2 without substitution. (Fire Prevention and Building Safety Commission; 675 IAC 22-2.3-338)

**675 IAC 22-2.3-339** Appendix A; board of appeals

Authority: IC 22-13-2-2  
Affected: IC 22-12-7; IC 22-13; IC 22-14; IC 36-8-17

**Sec. 339.** Appendix A Board of Appeals is amended to read as follows:

Appendix A-1; life-safety requirements for existing buildings other than high rise is adopted as follows:

Appendix I-A  
Emergency Escape Plan Sign Sample

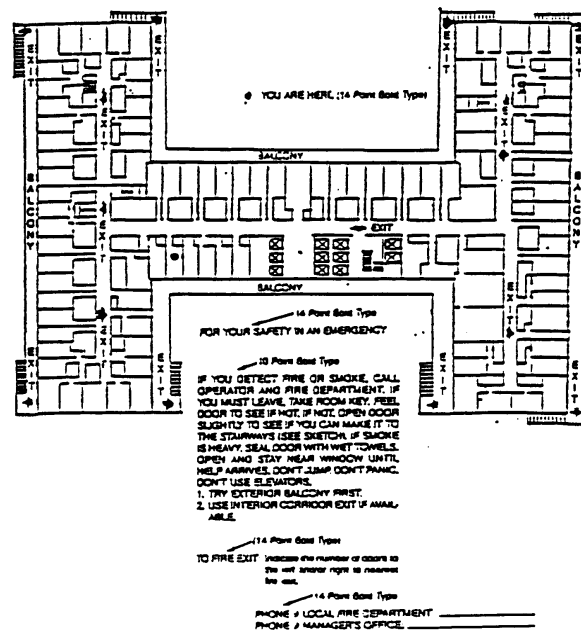

(Fire Prevention and Building Safety Commission; 675 IAC 22-2.3-339)

**675 IAC 22-2.3-340** Appendix A-2; life safety requirements for existing high-rise buildings

Authority: IC 22-13-2-2  
Affected: IC 22-12-7; IC 22-13; IC 22-14; IC 36-8-17

**Sec. 340.** Appendix A-2 is adopted as follows:

**Appendix I-B  
Emergency Information Sign Samples**

72 Point Bold Capitals  
**IN CASE OF FIRE**

24 Point Bold  
**If you smell smoke or the  
alarm sounds:**

18 Point Bold

Call Fire Department and Manager's Office  
Prepare to leave room  
Get Dressed - including shoes  
Take your apartment key - you might need to get back in  
Feel bedroom door  
If cool, open it slightly to see if there is any smoke  
If clear, proceed to nearest exit  
If door is hot, stay in room  
Evacuate through a bedroom window, if possible

24 Point Bold  
**Keep Calm - Don't Panic**

18 Point Bold

Fire Department Number \_\_\_\_\_  
Manager's Office Number \_\_\_\_\_

*(Fire Prevention and Building Safety Commission; 675 IAC 22-2.3-340)*

**675 IAC 22-2.3-341 Appendices B through G**

Authority: IC 22-13-2-2  
Affected: IC 22-12-7; IC 22-13; IC 22-14; IC 36-8-17

**Sec. 341. The following Appendices are not adopted but may be used for information purposes only:**

- (1) Appendix B; fire-flow requirements for buildings.
- (2) Appendix C; fire hydrant locations and distribution.
- (3) Appendix D; fire apparatus access roads.
- (4) Appendix E; hazard categories.
- (5) Appendix F; hazard ranking
- (6) Appendix G; cryogenic fluids—weight and volume equivalents.

*(Fire Prevention and Building Safety Commission; 675 IAC 22-2.3-341)*

**675 IAC 22-2.3-342 Appendix VI-F; recommended separation distances for explosives**

Authority: IC 22-13-2-2  
Affected: IC 22-12-7; IC 22-13; IC 22-14; IC 36-8-17

**Sec. 342. (a) Portions of this work are reproduced from the 1997 edition of the Uniform Fire Code, Appendix VI-F,**

copyright© 1997, with the permission of the publisher, the International Conference of Building Officials. ICBO assumes no responsibility for the accuracy or completion of summaries provided therein.

(b) Appendix VI-F to read as follows:

**APPENDIX VI-F**

**RECOMMENDED SEPARATION DISTANCES FOR EXPLOSIVE MATERIALS**

(See Chapter 33)

The following information is provided as reference information for application of Chapter 33 and IC 22-11-14.

The information provided in Section 1 is excerpted from federal regulations in 49 C.F.R. A discussion of the new regulations is also provided.

Table A-VI-F-5 is reprinted with permission of the Institute of Makers of Explosives with the provision that the entire table, complete with all explanatory footnotes, be printed. Table A-VI-F-5 is used for magazines containing high explosives or a combination of high explosives and low explosives, and for magazines containing blasting agents.

**SECTION 1 - CLASSIFICATION OF EXPLOSIVE MATERIALS**

Section 1 provides guidance regarding the classification of explosive materials. This guidance is necessary because of a new explosive materials classification system that has been adopted by the United States Department of Transportation.

The Indiana Fire Code regulates explosives based on a combination of two systems used by the federal government for classification of explosives. One system is used by DOT and applies to transportation of materials. The other system is used by the Bureau of Alcohol, Tobacco and Firearms (BATF) and applies to storage.

The Bureau of Alcohol, Tobacco and Firearms classifies explosives as either high explosives, low explosives or blasting agents as specified in 27 C.F.R. These high-explosive, low-explosive and blasting agent categories are used when determining some of the UFC requirements for storage of explosive materials. Some difficulty may be experienced when applying UFC regulations that refer to these categories because packages for explosive materials may not be labeled with these designations.

Package labels and markings for explosive materials are typically based on the classification system prescribed by

## Proposed Rules

DOT regulations in 49 C.F.R., Parts 171-173. For many years, this system has designated explosives as Class A, Class B, Class C or blasting agents. Effective October 1, 1991, DOT revised the rules covering the classification, description, shipping name, packaging, labeling and placarding for the transportation of explosives. These revised rules are based on United Nations (UN) Recommendations and were designed to bring existing DOT regulations into alignment with international regulations. Effective October 1, 1991, the classification, marking, labeling, shipping papers and emergency response information for all new explosives were required to be in accordance with the revised regulations.

For explosives approved prior to October 1, 1991, DOT has established transition dates to provide an orderly transition to the new regulations. See Table A-VI-F-1. Note that the execution date for mandatory use of placards based on UN Recommendations has been extended to October 1, 2001.

The new UN/DOT system classifies explosives as Class 1 materials. They are then divided into divisions to indicate their relative hazard. Unfortunately, there is not a direct correlation between the designations used by the old DOT system and those used by the new system. Tables A-VI-F-2 and A-VI-F-3 provide some guidance with regard to the new categories and their relationship to the old categories.

Additionally, all Class 1 materials are assigned a compatibility letter to show which materials, when grouped together, will not significantly increase the probability of an accident, or for a given quantity, increase the the magnitude of the effects from such an accident. See Table A-VI-F-4. During the transition period described in Table A-VI-F-1, special care should be taken to ensure that compatibility letters from the UN/DOT system are not confused with letters used to designate explosive classes under the old DOT classifications.

For additional information, see 49 C.F.R.

### SECTION 2 - RECOMMENDED SEPARATION DISTANCES FOR EXPLOSIVE MATERIALS

See Table A-VI-F-5.

**TABLE A-VI-F-1 - TRANSITION DATES FOR EXPLOSIVES CLASSIFICATIONS AND RELATED DOT REGULATIONS**

OCTOBER 1, 1991	DOT publishes new rules for explosives based on United Nations (UN) Recommendations. All new explosives must be classified under the new regulations.
OCTOBER 1, 1993	Mandatory compliance with new classification and hazard communication requirements except placarding.

OCTOBER 1, 1994	Mandatory use of new UN placards except existing DOT placards may continue to be used for domestic highway transport. Package manufacturers will only be permitted to make nonbulk packaging which meet United Nations performance standards.
OCTOBER 1, 1996	Mandatory use of performance-oriented packaging standards based on United Nations Recommendations for nonbulk packaging.
OCTOBER 1, 2001	Mandatory use of new United Nations placards for all modes of transportation.

**TABLE A-VI-F-2 - DEFINITIONS FOR DIVISIONS OF CLASS 1 (EXPLOSIVE) MATERIALS**

DIVISION	DEFINITION
1.1	Explosives that have a mass hazard explosion. A mass explosion is one which affects almost the entire load instantaneously. (Examples include dynamite, cap-sensitive water gels, slurries, emulsions and cast boosters.)
1.2	Explosives that have a projection hazard but not a mass explosion hazard. (Examples include ammunition, projectiles and bombs.)
1.3	Explosives that have a fire hazard and either a minor blast hazard or a minor projection hazard or both, but not a mass explosion hazard. (Examples include some propellants, some fireworks and flares.)
1.4	Explosive devices that present a minor explosion hazard. External fire must not cause virtually instantaneous explosion of almost the entire contents of the package. (Examples include some detonators and detonating cords, safety fuse, electric squibs, igniters, igniting cord and some fireworks.)
1.5	Very insensitive explosives. This division is comprised of substances which have a mass explosion hazard but are so insensitive that there is very little probability of initiation or of transition from burning to detonation under normal conditions of transport. (Examples include blasting agents.)
1.6	Extremely insensitive articles which do not have a mass explosion hazard. This division is comprised of articles which contain only extremely insensitive detonation substances and which demonstrate a negligible probability of accidental initiation or propagation. (This division is not commonly used for commercial explosives.)

**TABLE A-VI-F-3 - COMPARISON OF OLD TO CURRENT EXPLOSIVES CLASSIFICATIONS**

CLASS A EXPLOSIVES	May be either DIVISION 1.1 or 1.2 depending of the material
CLASS B EXPLOSIVES	May be either DIVISION 1.2 or 1.3 depending of the material
CLASS C EXPLOSIVES	DIVISION 1.4
BLASTING AGENTS	DIVISION 1.5
(NO APPLICABLE CLASS)	DIVISION 1.6



**TABLE A-VI-F-4 - EXPLOSIVES COMPATIBILITY GROUPS**

DESCRIPTION OF SUBSTANCES OR ARTICLE TO BE CLASSIFIED	COMPATIBILITY GROUP	CLASSIFICATION CODE
Primary explosive substance.	A	1.1A
Article containing a primary explosive substance and not containing two or more effective protective substances.	B	1.1B 1.2B 1.4B
Propellant explosive substance or other deflagrating explosive substance or article containing such explosive substance.	C	1.1C 1.2C 1.3C 1.4C
Secondary detonating explosive substance or black powder or article containing a secondary detonating explosive substance, in each case without means of initiation and without a propelling charge, or article containing a primary explosive substance and containing two or more effective protective features.	D	1.1D 1.2D 1.4D 1.5D
Article containing a secondary detonating explosive substance, without means of initiation, with a propelling charge (other than one containing flammable liquid or hypergolic liquid).	E	1.1E 1.2E 1.4E
Article containing a secondary detonating explosive substance with its means of initiation, with a propelling charge (other than one containing flammable liquid or hypergolic liquid) or without a propelling charge.	F	1.1F 1.2F 1.3F 1.4F

Pyrotechnic substance or article containing a pyrotechnic substance, or article containing both an explosive substance and an illuminating, incendiary, tear-producing or smoke-producing substance (other than a water-activated article or one containing white phosphorus, phosphide or flammable liquid or gel or hypergolic liquid).	G	1.1G 1.2G 1.3G 1.4G
Article containing both an explosive substance and white phosphorus.	H	1.2H 1.3H
Article containing both an explosive substance and flammable liquid or gel.	J	1.1J 1.2J 1.3J
Article containing both an explosive substance and a toxic chemical agent.	K	1.2K 1.3K
Explosive substance or article containing an explosive substance and presenting a special risk (e.g., due to water-activation or presence of hypergolic liquids, phosphides or pyrophoric substances) needing isolation of each type.	L	1.1L 1.2L 1.3L
Articles containing only extremely insensitive detonating substances.	N	1.6N
Substance or article so packed or designed that any hazardous effects arising from accidental functioning are limited to the extent that they do not significantly hinder or prohibit fire fighting or other emergency response efforts in the immediate vicinity of the package.	S	1.4S

# Proposed Rules

**TABLE A-VI-F-5—AMERICAN TABLE OF DISTANCES FOR STORAGE OF EXPLOSIVE MATERIALS**  
As Revised and Approved by the Institute of Makers of Explosives—June 1991<sup>14</sup>

QUANTITY OF EXPLOSIVE MATERIALS <sup>1,2,3,4,5</sup>		DISTANCES IN FEET									
		x 304.8 for mm									
		Pounds Over x 0.454 for kg		Inhabited Buildings <sup>6</sup>		Public Highways with Traffic Volume of less than 3,000 Vehicles per Day		Passenger Railways—Public Highways with Traffic Volume of more than 2,000 Vehicles/Day <sup>10,11</sup>		Separation of Magazines <sup>6, 12</sup>	
				Barricaded <sup>6,7,8</sup>	Unbarricaded	Barricaded <sup>6,7,8</sup>	Unbarricaded	Barricaded <sup>6,7,8</sup>	Unbarricaded	Barricaded <sup>6,7,8</sup>	Unbarricaded
Pounds Not Over											
0	5	70	140	30	60	51	102	6	12		
5	10	90	180	35	70	64	128	8	16		
10	20	110	220	45	90	81	162	10	20		
20	30	125	250	50	100	93	186	11	22		
30	40	140	280	55	110	103	206	12	24		
40	50	150	300	60	120	110	220	14	28		
50	75	170	340	70	140	127	254	15	30		
75	100	190	380	75	150	139	278	16	32		
100	125	200	400	80	160	150	300	18	36		
125	150	215	430	85	170	159	318	19	38		
150	200	235	470	95	190	175	350	21	42		
200	250	255	510	105	210	189	378	23	46		
250	300	270	540	110	220	201	402	24	48		
300	400	295	590	120	240	221	442	27	54		
400	500	320	640	130	260	238	476	29	58		
500	600	340	680	135	270	253	506	31	62		
600	700	355	710	145	290	266	522	32	64		
700	800	375	750	150	300	278	556	33	66		
800	900	390	780	155	310	289	578	34	70		
900	1,000	400	800	160	320	300	600	36	72		
1,000	1,200	425	850	165	330	318	636	39	78		
1,200	1,400	450	900	170	340	336	672	41	82		
1,400	1,600	470	940	175	350	351	702	43	86		
1,600	1,800	490	980	180	360	366	732	44	88		
1,800	2,000	505	1,010	185	370	378	756	45	90		
2,000	2,500	545	1,090	190	380	408	816	49	98		
2,500	3,000	580	1,160	195	390	432	864	52	104		
3,000	4,000	635	1,270	210	420	474	949	58	116		
4,000	5,000	685	1,370	225	450	513	1,026	61	122		
5,000	6,000	730	1,460	235	470	546	1,092	65	130		
6,000	7,000	770	1,540	245	490	573	1,146	68	136		
7,000	8,000	800	1,600	250	500	600	1,200	72	144		
8,000	9,000	835	1,670	255	510	624	1,248	75	150		
9,000	10,000	865	1,730	260	520	645	1,290	78	156		
10,000	12,000	875	1,750	270	520	687	1,374	82	164		
12,000	14,000	885	1,770	275	550	723	1,446	87	174		
14,000	16,000	900	1,800	280	560	756	1,512	90	180		
16,000	18,000	940	1,880	285	570	786	1,572	94	188		
18,000	20,000	975	1,950	290	580	813	1,626	98	196		
20,000	25,000	1,055	2,000	315	630	876	1,752	105	210		
25,000	30,000	1,130	2,000	340	680	933	1,866	112	224		
30,000	35,000	1,205	2,000	360	720	981	1,962	119	238		
35,000	40,000	1,275	2,000	380	760	1,026	2,000	124	248		
40,000	45,000	1,340	2,000	400	800	1,068	2,000	129	258		
45,000	50,000	1,400	2,000	420	840	1,104	2,000	135	270		
50,000	55,000	1,460	2,000	440	880	1,140	2,000	140	280		
55,000	60,000	1,515	2,000	455	910	1,173	2,000	145	290		
60,000	65,000	1,565	2,000	470	940	1,206	2,000	150	300		
65,000	70,000	1,610	2,000	485	970	1,236	2,000	155	310		
70,000	75,000	1,655	2,000	500	1,000	1,263	2,000	160	320		
75,000	80,000	1,695	2,000	510	1,020	1,293	2,000	165	330		
80,000	85,000	1,730	2,000	520	1,040	1,317	2,000	170	340		
85,000	90,000	1,760	2,000	530	1,060	1,344	2,000	175	350		
90,000	95,000	1,790	2,000	540	1,080	1,368	2,000	180	360		
95,000	100,000	1,815	2,000	545	1,090	1,392	2,000	185	370		
100,000	110,000	1,835	2,000	550	1,100	1,437	2,000	195	390		
110,000	120,000	1,855	2,000	555	1,110	1,479	2,000	205	410		
120,000	130,000	1,875	2,000	560	1,120	1,521	2,000	215	430		
130,000	140,000	1,890	2,000	565	1,130	1,557	2,000	225	450		
140,000	150,000	1,900	2,000	570	1,140	1,593	2,000	235	470		

(Continued)

TABLE A-VI-F-5—AMERICAN TABLE OF DISTANCES FOR STORAGE OF EXPLOSIVE MATERIALS—(Continued)  
As Revised and Approved by the Institute of Makers of Explosives—June 1991<sup>14</sup>

QUANTITY OF EXPLOSIVE MATERIALS <sup>1,2,3,4,13</sup>		DISTANCES IN FEET							
		× 304.8 for m							
		Inhabited Buildings <sup>9</sup>		Public Highways with Traffic Volume of less than 3,000 Vehicles per Day		Passenger Railways—Public Highways with Traffic Volume of more than 3,000 Vehicles/Day <sup>10,11</sup>		Separation of Magazines <sup>5, 12</sup>	
Pounds Over	Pounds Not Over	Barricaded <sup>6,7,8</sup>	Unbarricaded	Barricaded <sup>6,7,8</sup>	Unbarricaded	Barricaded <sup>6,7,8</sup>	Unbarricaded	Barricaded <sup>6,7,8</sup>	Unbarricaded
× 0.454 for kg									
150,000	160,000	1,935	2,000	580	1,160	1,629	2,000	245	490
160,000	170,000	1,990	2,000	590	1,180	1,662	2,000	255	510
170,000	180,000	2,010	2,000	600	1,200	1,695	2,000	265	530
180,000	190,000	2,030	2,010	605	1,210	1,725	2,000	275	550
190,000	200,000	2,055	2,030	610	1,220	1,755	2,000	285	570
200,000	210,000	2,055	2,055	620	1,240	1,762	2,000	295	590
210,000	230,000	2,100	2,100	635	1,270	1,836	2,000	315	630
230,000	250,000	2,155	2,155	650	1,300	1,890	2,000	335	670
250,000	275,000	2,215	2,215	670	1,340	1,950	2,000	360	720
275,000	300,000 <sup>13</sup>	2,275	2,275	690	1,380	2,000	2,000	385	770

<sup>1</sup>"Explosive materials" means explosives, blasting agents and detonators.

<sup>2</sup>"Explosives" means any chemical compound, mixture or device, the primary or common purpose of which is to function by explosion. A list of explosives determined to be within the coverage of 18 USC Chapter 40, Importation, Manufacturer, Distribution and Storage of Explosive Materials, is issued at least annually by the director of the Bureau of Alcohol, Tobacco and Firearms of the Department of the Treasury. For quantity and distance purposes, detonating cord of 50 grains per foot (10.7 g/m) should be calculated as equivalent to 8 pounds (3.6 kg) of high explosives per 1,000 feet (304.8 m). Heavier or lighter core loads should be rated proportionately.

<sup>3</sup>"Blasting agents" means any material or mixture, consisting of fuel and oxidizer, intended for blasting, not otherwise defined as an explosive, provided that the finished product, as mixed for use or shipment, cannot be detonated by means of a No. 8 test blasting cap when unconfined.

<sup>4</sup>"Detonator" means any device containing any initiating or primary explosive that is used for initiating detonation. A detonator may not contain more than 10 grams of total explosives by weight, excluding ignition or delay charges. The term includes, but is not limited to, electric blasting caps of instantaneous and delay types, blasting caps for use within safety fuses, detonating cord delay connectors, and non-electric instantaneous and delay blasting caps which use detonating cord, shock tube or any other replacement for electric leg wires. All types of detonators in strengths through No. 8 cap should be rated at 1 1/2 pounds (0.68 kg) of explosives per 1,000 caps. For strengths higher than No. 8 cap, consult the manufacturer.

<sup>5</sup>"Magazine" means any building, structure or container, other than an explosives manufacturing building, approved for the storage of explosive materials.

<sup>6</sup>"Natural barricade" means natural features of the ground such as hills, or timber of sufficient density that the surrounding exposures which require protection cannot be seen from the magazine when the trees are bare of leaves.

<sup>7</sup>"Artificial barricade" means an artificial mound or revetted wall of earth of a minimum thickness of 3 feet (914.4 mm).

<sup>8</sup>"Barricaded" means the effective screening of a building containing explosive materials from the magazine or other building, railway or highway by a natural or an artificial barrier. A straight line from the top of any side wall of the building containing explosive materials to the eave line of any magazine or other building or to a point 12 feet (3657.6 mm) above the center of a railway or highway shall pass through such barrier.

<sup>9</sup>"Inhabited building" means a building regularly occupied in whole or part as a habitation for human beings, or any church, schoolhouse, railroad station, store or other structure where people are accustomed to assemble, except any building or structure occupied in connection with the manufacture, transportation, storage or use of explosive materials.

<sup>10</sup>"Railway" means any steam, electric or other railroad or railway which carries passengers for hire.

<sup>11</sup>"Highway" means any public street, public alley or public road.

<sup>12</sup>When two or more storage magazines are located on the same property, each magazine must comply with the minimum distances specified from inhabited buildings, railways and highways, and in addition, they should be separated from each other by not less than the distances shown for "Separation of Magazines," except that the quantity of explosive materials contained in detonator magazines shall govern in regard to the spacing of said detonator magazines from magazines containing other explosive materials. If any two or more magazines are separated from each other by less than the specified "Separation of Magazines" distances, then such two or more magazines, as a group, must be considered as one magazine, and the total quantity of explosive materials stored in such group must be treated as if stored in a single magazine located on the site of any magazine of the group, and must comply with the minimum of distances specified from other magazines, inhabited buildings, railways and highways.

<sup>13</sup>Storage in excess of 300,000 pounds (136 077.6 kg) of explosive materials in one magazine is generally not required for commercial enterprises.

<sup>14</sup>This table applies only to the manufacture and permanent storage of commercial explosive materials. It is not applicable to transportation of explosives or any handling or temporary storage necessary or incidental thereto. It is not intended to apply to bombs, projectiles or other heavily encased explosives.

<sup>15</sup>When a manufacturing building on an explosive materials plant site is designed to contain explosive materials, such building shall be located from inhabited buildings, public highways and passenger railways in accordance with Table A-VI-F-5 based on the maximum quantity of explosive materials permitted to be in the building at one time.

NOTE: The American Table of Distances (Table A-VI-F-5) is reprinted by permission of the Institute of Makers of Explosives with the provision that the entire table, complete with all explanatory footnotes, be printed.

# Proposed Rules

**TABLE A-VI-F-6—TABLE OF RECOMMENDED SEPARATION DISTANCES OF AMMONIUM NITRATE AND BLASTING AGENTS FROM EXPLOSIVES OR BLASTING AGENTS<sup>1,6</sup>**

DONOR WEIGHT		MINIMUM SEPARATION DISTANCE OF ACCEPTOR WHEN BARRICADED <sup>2</sup> (feet)		MINIMUM THICKNESS OF ARTIFICIAL BARRICADES <sup>5</sup> (inches)
Pounds Over	Pounds Not Over	x 304.8 for mm		
x 0.454 for kg		Ammonium Nitrate <sup>3</sup>	Blasting Agent <sup>4</sup>	
				x 25.4 for mm
	100	3	11	12
100	300	4	14	12
300	600	5	18	12
600	1,000	6	22	12
1,000	1,600	7	25	12
1,600	2,000	8	29	12
2,000	3,000	9	32	15
3,000	4,000	10	36	15
4,000	6,000	11	40	15
6,000	8,000	12	42	20
8,000	10,000	13	47	20
10,000	12,000	14	50	20
12,000	16,000	15	54	25
16,000	20,000	16	58	25
20,000	25,000	18	65	25
25,000	30,000	19	68	30
30,000	35,000	20	72	30
35,000	40,000	21	76	30
40,000	45,000	22	79	35
45,000	50,000	23	83	35
50,000	55,000	24	86	35
55,000	60,000	25	90	35
60,000	70,000	26	94	40
70,000	80,000	28	101	40
80,000	90,000	30	108	40
90,000	100,000	32	115	40
100,000	120,000	34	122	50
120,000	140,000	37	133	50
140,000	160,000	40	144	50
160,000	180,000	44	158	50
180,000	200,000	48	173	50
200,000	220,000	52	187	60
220,000	250,000	56	202	60
250,000	275,000	60	216	60
275,000	300,000	64	230	60

<sup>1</sup>Recommended separation distances to prevent explosion of ammonium nitrate and ammonium nitrate-based agents by propagation from nearby stores of high explosives or blasting agents referred to in Table A-VI-F-6 as the "donor." Ammonium nitrate, by itself, is not considered to be a donor when applying Table A-VI-F-6. Ammonium nitrate, ammonium nitrate-fuel oil or combination thereof are acceptors. If stores of ammonium nitrate are located within the sympathetic detonation distance of explosives or blasting agents, one-half the mass of the ammonium nitrate should be included in the mass of the donor.

<sup>2</sup>When the ammonium nitrate or blasting agent is not barricaded, the distances shown in Table A-VI-F-6 shall be multiplied by six. These distances allow for the possibility of high velocity metal fragments from mixers, hoppers, truck bodies, sheet metal structures, metal containers and the like which may enclose the "donor." Where storage is in bullet-resistant magazines recommended for explosives or where the storage is protected by a bullet-resistant wall, distances and barricade thicknesses in excess of those prescribed in Table A-VI-F-5, Footnote 7, are not required. For construction of bullet-resistant magazines, see Article 77.

<sup>3</sup>The distances in Table A-VI-F-6 apply to ammonium nitrate that passes the insensitivity test prescribed in the definition of ammonium nitrate fertilizer promulgated by the Fertilizer Institute (Definitions and Test Procedures for Ammonium Nitrate Fertilizer, Fertilizer Institute 1964); and ammonium nitrate failing to pass said test shall be stored at separation distances determined by competent persons and approved by the authority having jurisdiction.

<sup>4</sup>These distances apply to blasting agents which pass the insensitivity test prescribed in regulations of the United States Department of Transportation and the United States Department of the Treasury, Bureau of Alcohol, Tobacco and Firearms.

<sup>5</sup>Earth, or sand dikes, or enclosures filled with the prescribed minimum thickness of earth or sand are acceptable artificial barricades. Natural barricades, such as hills or timber of sufficient density that the surrounding exposures which require protection cannot be seen from the "donor" when the trees are bare of leaves, are also acceptable.

<sup>6</sup>For determining the distances to be maintained from inhabited buildings, passenger railways and public highways, see Table A-VI-F-5 (High Explosives and Blasting Agents) or Table A-VI-F-7 (Low Explosives).

**TABLE A-VI-F-7  
TABLE OF DISTANCES FOR STORAGE OF LOW EXPLOSIVES**

LOW EXPLOSIVES (pounds)		FROM INHABITED BUILDING DISTANCE (feet)	FROM PUBLIC RAILROAD AND HIGHWAY DISTANCE (feet)	FROM ABOVEGROUND MAGAZINE (feet)
x 0.454 for kg				
Over	Not Over	x 304.8 for mm		
0	1,000	75	75	60
1,000	5,000	115	115	75
5,000	10,000	130	130	100
10,000	20,000	180	180	225
20,000	30,000	215	215	145
30,000	40,000	235	235	155
40,000	50,000	250	250	165
50,000	60,000	260	260	175
60,000	70,000	270	270	185
70,000	80,000	300	300	190
80,000	90,000	325	325	195
90,000	100,000	350	350	200
100,000	200,000	375	375	250
200,000	300,000	400	400	300

TABLE A-VI-F-8—DISTANCES FOR THE OPEN BURNING OF EXPLOSIVES<sup>1</sup>

QUANTITY OF EXPLOSIVES <sup>2,3,4,5</sup> (Not Over)	MINIMUM DISTANCE IN FEET							Separation From Other Open Burning Units
	x 304.8 for mm							
	Inhabited Buildings <sup>9</sup>		Public Highways with Traffic Volume of less than 3,000 Vehicles per Day <sup>10</sup>		Passenger Railways and Public Highways with Traffic Volume more than 3,000 Vehicles per Day <sup>11</sup>			
Pounds x 0.454 for kg	No Missile Hazard	Missile Hazard without Barricade <sup>6,7,8</sup>	No Missile Hazard	Missile Hazard without Barricade <sup>6,7,8</sup>	No Missile Hazard	Missile Hazard without Barricade <sup>6,7,8</sup>		
10	90	180	35	70	64	128	8	
20	110	220	45	90	81	162	10	
50	150	300	60	120	110	220	14	
75	170	340	70	140	127	254	15	
100	190	380	75	150	139	278	16	
250	255	510	105	210	189	378	23	
500	320	640	130	260	238	476	29	
1,000	400	800	160	320	300	600	36	
1,600	470	940	175	350	351	702	43	
2,000	505	1,010	185	370	378	756	45	
2,500	545	1,090	190	380	408	816	49	
3,000	580	1,160	195	390	432	864	52	
4,000	635	1,270	210	420	474	948	58	
5,000	685	1,370	225	450	513	1,026	61	
6,000	730	1,460	235	470	546	1,092	65	
7,000	770	1,540	245	490	573	1,146	68	
8,000	800	1,600	250	500	600	1,200	72	
9,000	835	1,670	255	510	624	1,248	75	
10,000	865	1,730	260	520	645	1,290	78	

- <sup>1</sup>This table is intended only for application of open burning of commercial explosive materials. The distances stated in this table should be measured from the center of the unit, except for separations from other open burning units, which are measured from the edge of the unit.
- <sup>2</sup>Explosive materials" means any explosive, slurry, emulsion, detonating cord, blasting agents and detonators.
- <sup>3</sup>Explosives" means any chemical compound, mixture or device, the primary or common purpose of which is to function by explosion. A list of explosives determined to be within the coverage of 18 U.S.C. Chapter 40, Importation, Manufacture, Distribution and Storage of Explosive Material, is issued at least annually by the director of the Bureau of Alcohol, Tobacco and Firearms of the Department of the Treasury. For quantity and distance purposes, detonating cord of 50 grains per foot (10.7 g/m) should be calculated as equivalent to 8 pounds (3.6 kg) of high explosives per 1,000 feet (304.8 m). Heavier or lighter core loads should be rated proportionally.
- <sup>4</sup>Blasting agents" means any material or mixture, consisting of fuel and oxidizer, intended for blasting, not otherwise defined as an explosive, provided the finished product, as mixed for use or shipment, cannot be detonated by means of a No. 8 test blasting cap when unconfined.
- <sup>5</sup>Detonator" means any device containing any initiating or primary explosive that is used for initiating detonation. A detonator may not contain more than 10 grams of total explosives by weight, excluding ignition or delay charges. The term includes, but is not limited to, electric blasting caps of instantaneous and delay blasting caps which use detonating cord, shock tube or any other replacement for electric wires. All types of detonators in strengths through No. 8 cap should be rated at 1 1/2 pounds (0.68 kg) of explosives per 1,000 caps. For strengths higher than No. 8 cap, consult the manufacturer.
- <sup>6</sup>Natural barricade" means natural features of the ground, such as hills, or timber of sufficient density that the surrounding exposures that require protection cannot be seen from the magazine when the trees are bare of leaves.
- <sup>7</sup>Artificial barricade" means an artificial mound or revetted wall of earth of a minimum thickness of 3 feet (914.4 mm).
- <sup>8</sup>Barricaded" means the effective screening of a building containing explosive materials from the magazine or other building, OB/OD site, railway or highway by a natural or an artificial barrier. A straight line from the top of any sidewall of the building containing explosive materials to the eave line of any magazine or other building or to a point 12 feet (3657.6 mm) above the center of a railway or highway shall pass through such a barrier.
- <sup>9</sup>Inhabited building" means a building, regularly occupied in whole or part as a habitation for human beings, or any church, schoolhouse, railroad station, store, or other structure where people are accustomed to assemble. This does not mean any office, warehouse, production, laboratory or other buildings that are a part of the facility where the open burning or open detonation sites are located.
- <sup>10</sup>Highway" means any public street, public alley or public road.
- <sup>11</sup>Railway" means any steam, electric or other railroad or railway which carries passengers for hire.

TABLE A-VI-F-9—DISTANCES FOR THE OPEN DETONATION OF EXPLOSIVES<sup>1</sup>

QUANTITY OF EXPLOSIVES <sup>2,3,4,5</sup> (Not Over)	MINIMUM DISTANCE IN FEET							Separation From Other Open Detonation Units
	x 304.8 for mm							
	Inhabited Building <sup>9</sup>		Public Highways with Traffic Volume of less than 3,000 Vehicles per Day <sup>10</sup>		Passenger Railways and Public Highways with Traffic Volume of more than 3,000 Vehicles per Day <sup>11</sup>			
Pounds x 0.454 for kg	No Missile Hazard	Missile Hazard without Barricade <sup>6,7,8</sup>	No Missile Hazard	Missile Hazard without Barricade <sup>6,7,8</sup>	No Missile Hazard	Missile Hazard without Barricade <sup>6,7,8</sup>	No Missile Hazard	Missile Hazard without Barricade <sup>6,7,8</sup>
1	730	730	325	325	480	480	6	12
2	920	920	410	410	600	600	6	12
5	1,250	1,250	550	550	820	820	6	12
10	1,600	1,600	695	695	1,030	1,030	8	16
20	1,990	1,990	875	875	1,295	1,295	10	20
50	2,700	2,700	1,190	1,190	1,760	1,760	14	28
75	3,080	3,080	1,360	1,360	2,015	2,015	15	30
100	3,400	3,400	1,500	1,500	2,220	2,220	16	32
150	3,900	3,900	1,715	1,715	2,535	2,535	19	38
200	4,275	4,275	1,890	1,890	2,795	2,795	21	42
300	4,900	4,900	2,160	2,160	3,200	3,200	24	48
400	5,400	5,400	2,380	2,380	3,520	3,520	27	54
500	5,800	5,800	2,560	2,560	3,790	3,790	29	58

- <sup>1</sup>Table A-VI-F-9 is intended only for application of open detonation of commercial explosive materials. The distances stated in Table A-VI-F-9 should be measured from the center of the unit, except for separations from other open detonation units, which are measured from the edge of the unit.
- <sup>2</sup>Explosive materials" means any explosive, slurry, emulsion, detonating cord, blasting agents and detonators.
- <sup>3</sup>Explosives" means any chemical compound, mixture or device, the primary or common purpose of which is to function by explosion. A list of explosives determined to be within the coverage of 18 U.S.C. Chapter 40, Importation, Manufacture, Distribution and Storage of Explosive Material, is issued at least annually by the director of the Bureau of Alcohol, Tobacco and Firearms of the Department of the Treasury. For quantity and distance purposes, detonating cord of 50 grains per foot (10.7 g/m) should be calculated as equivalent to 8 pounds (3.6 kg) of high explosives per 1,000 feet (304.8 m). Heavier or lighter core loads should be rated proportionally.
- <sup>4</sup>Blasting agents" means any material or mixture, consisting of fuel and oxidizer, intended for blasting, not otherwise defined as an explosive, provided the finished product, as mixed for use or shipment, cannot be detonated by means of a No. 8 test blasting cap when unconfined.
- <sup>5</sup>Detonator" means any device containing any initiating or primary explosive that is used for initiating detonation. A detonator may not contain more than 10 grams of total explosives by weight, excluding ignition or delay charges. The term includes, but is not limited to, electric blasting caps of instantaneous and delay blasting caps which use detonating cord, shock tube or any other replacement for electric wires. All types of detonators in strengths through No. 8 cap should be rated at 1 1/2 pounds (0.68 kg) of explosives per 1,000 caps. For strengths higher than No. 8 cap, consult the manufacturer.
- <sup>6</sup>Natural barricade" means natural features of the ground, such as hills, or timber of sufficient density that the surrounding exposures that require protection cannot be seen from the magazine when the trees are bare of leaves.
- <sup>7</sup>Artificial barricade" means an artificial mound or revetted wall of earth of a minimum thickness of 3 feet (914.4 mm).
- <sup>8</sup>Barricaded" means the effective screening of a building containing explosive materials from the magazine or other building, OB/OD site, railway or highway by a natural or an artificial barrier. A straight line from the top of any sidewall of the building containing explosive materials to the eave line of any magazine or other building or to a point 12 feet (3657.6 mm) above the center of a railway or highway shall pass through such a barrier.
- <sup>9</sup>Inhabited building" means a building, regularly occupied in whole or part as a habitation for human beings, or any church, schoolhouse, railroad station, store, or other structure where people are accustomed to assemble. This does not mean any office, warehouse, production, laboratory or other buildings that are a part of the facility where the open burning or open detonation sites are located.
- <sup>10</sup>Highway" means any public street, public alley or public road.
- <sup>11</sup>Railway" means any steam, electric or other railroad or railway which carries passengers for hire.

(Fire Prevention and Building Safety Commission; 675 IAC 22-2.3-342)



22-2.2-333; 675 IAC 22-2.2-334; 675 IAC 22-2.2-335; 675 IAC 22-2.2-336; 675 IAC 22-2.2-337; 675 IAC 22-2.2-338; 675 IAC 22-2.2-339; 675 IAC 22-2.2-340; 675 IAC 22-2.2-341; 675 IAC 22-2.2-342; 675 IAC 22-2.2-343; 675 IAC 22-2.2-344; 675 IAC 22-2.2-345; 675 IAC 22-2.2-346; 675 IAC 22-2.2-347; 675 IAC 22-2.2-348; 675 IAC 22-2.2-349; 675 IAC 22-2.2-350; 675 IAC 22-2.2-351; 675 IAC 22-2.2-352; 675 IAC 22-2.2-353; 675 IAC 22-2.2-354; 675 IAC 22-2.2-355; 675 IAC 22-2.2-356; 675 IAC 22-2.2-357; 675 IAC 22-2.2-358; 675 IAC 22-2.2-359; 675 IAC 22-2.2-360; 675 IAC 22-2.2-361; 675 IAC 22-2.2-362; 675 IAC 22-2.2-363; 675 IAC 22-2.2-364; 675 IAC 22-2.2-365; 675 IAC 22-2.2-366; 675 IAC 22-2.2-367; 675 IAC 22-2.2-368; 675 IAC 22-2.2-369; 675 IAC 22-2.2-370; 675 IAC 22-2.2-371; 675 IAC 22-2.2-372; 675 IAC 22-2.2-373; 675 IAC 22-2.2-374; 675 IAC 22-2.2-375; 675 IAC 22-2.2-376; 675 IAC 22-2.2-377; 675 IAC 22-2.2-378; 675 IAC 22-2.2-379; 675 IAC 22-2.2-380; 675 IAC 22-2.2-381; 675 IAC 22-2.2-382; 675 IAC 22-2.2-383; 675 IAC 22-2.2-384; 675 IAC 22-2.2-385; 675 IAC 22-2.2-386; 675 IAC 22-2.2-387; 675 IAC 22-2.2-388; 675 IAC 22-2.2-389; 675 IAC 22-2.2-390; 675 IAC 22-2.2-391; 675 IAC 22-2.2-392; 675 IAC 22-2.2-393; 675 IAC 22-2.2-394; 675 IAC 22-2.2-395; 675 IAC 22-2.2-396; 675 IAC 22-2.2-397; 675 IAC 22-2.2-398; 675 IAC 22-2.2-399; 675 IAC 22-2.2-400; 675 IAC 22-2.2-401; 675 IAC 22-2.2-402; 675 IAC 22-2.2-403; 675 IAC 22-2.2-404; 675 IAC 22-2.2-405; 675 IAC 22-2.2-406; 675 IAC 22-2.2-407; 675 IAC 22-2.2-408; 675 IAC 22-2.2-409; 675 IAC 22-2.2-410; 675 IAC 22-2.2-411; 675 IAC 22-2.2-412; 675 IAC 22-2.2-413; 675 IAC 22-2.2-414; 675 IAC 22-2.2-415; 675 IAC 22-2.2-416; 675 IAC 22-2.2-417; 675 IAC 22-2.2-418; 675 IAC 22-2.2-419; 675 IAC 22-2.2-420; 675 IAC 22-2.2-421; 675 IAC 22-2.2-422; 675 IAC 22-2.2-423; 675 IAC 22-2.2-424; 675 IAC 22-2.2-425; 675 IAC 22-2.2-426; 675 IAC 22-2.2-427; 675 IAC 22-2.2-428; 675 IAC 22-2.2-429; 675 IAC 22-2.2-430; 675 IAC 22-2.2-431; 675 IAC 22-2.2-432; 675 IAC 22-2.2-433; 675 IAC 22-2.2-434; 675 IAC 22-2.2-435; 675 IAC 22-2.2-436; 675 IAC 22-2.2-437; 675 IAC 22-2.2-438; 675 IAC 22-2.2-439; 675 IAC 22-2.2-440; 675 IAC 22-2.2-441; 675 IAC 22-2.2-442; 675 IAC 22-2.2-443; 675 IAC 22-2.2-444; 675 IAC 22-2.2-445; 675 IAC 22-2.2-446; 675 IAC 22-2.2-447; 675 IAC 22-2.2-448; 675 IAC 22-2.2-449; 675 IAC 22-2.2-450; 675 IAC 22-2.2-451; 675 IAC 22-2.2-452; 675 IAC 22-2.2-453; 675 IAC 22-2.2-454; 675 IAC 22-2.2-455; 675 IAC 22-2.2-456; 675 IAC 22-2.2-457; 675 IAC 22-2.2-458; 675 IAC 22-2.2-459; 675 IAC 22-2.2-460; 675 IAC 22-2.2-461; 675 IAC 22-2.2-462; 675 IAC 22-2.2-463; 675 IAC 22-2.2-464; 675 IAC 22-2.2-465; 675 IAC 22-2.2-466; 675 IAC 22-2.2-467; 675 IAC 22-2.2-468; 675 IAC 22-2.2-469; 675 IAC 22-2.2-470; 675 IAC 22-2.2-471; 675 IAC 22-2.2-472; 675 IAC 22-2.2-473; 675 IAC 22-2.2-474; 675 IAC 22-2.2-475; 675 IAC 22-2.2-476; 675 IAC 22-2.2-477; 675 IAC 22-2.2-478; 675 IAC 22-2.2-479; 675 IAC 22-2.2-480; 675 IAC 22-2.2-481; 675 IAC 22-2.2-482; 675 IAC 22-2.2-483; 675 IAC 22-2.2-484; 675 IAC 22-2.2-485; 675 IAC 22-2.2-486; 675 IAC 22-2.2-487; 675 IAC 22-2.2-488; 675 IAC 22-2.2-489; 675 IAC 22-2.2-490; 675 IAC 22-2.2-491; 675 IAC 22-2.2-492; 675 IAC 22-2.2-493; 675 IAC 22-2.2-494; 675 IAC

22-2.2-495; 675 IAC 22-2.2-496; 675 IAC 22-2.2-497; 675 IAC 22-2.2-498; 675 IAC 22-2.2-499; 675 IAC 22-2.2-500; 675 IAC 22-2.2-501; 675 IAC 22-2.2-502; 675 IAC 22-2.2-503; 675 IAC 22-2.2-504; 675 IAC 22-2.2-505; 675 IAC 22-2.2-506; 675 IAC 22-2.2-507; 675 IAC 22-2.2-508; 675 IAC 22-2.2-509; 675 IAC 22-2.2-510; 675 IAC 22-2.2-511; 675 IAC 22-2.2-512; 675 IAC 22-2.2-513; 675 IAC 22-2.2-514; 675 IAC 22-2.2-515; 675 IAC 22-2.2-516; 675 IAC 22-2.2-517; 675 IAC 22-2.2-518; 675 IAC 22-2.2-519; 675 IAC 22-2.2-520; 675 IAC 22-2.2-521; 675 IAC 22-2.2-522; 675 IAC 22-2.2-523; 675 IAC 22-2.2-524; 675 IAC 22-2.2-525; 675 IAC 22-2.2-526; 675 IAC 22-2.2-527; 675 IAC 22-2.2-528; 675 IAC 22-2.2-529; 675 IAC 22-2.2-530; 675 IAC 22-2.2-531; 675 IAC 22-2.2-532; 675 IAC 22-2.2-533; 675 IAC 22-2.2-534; 675 IAC 22-2.2-535; 675 IAC 22-2.2-536; 675 IAC 22-2.2-537; 675 IAC 22-2.2-538; 675 IAC 22-2.2-539.

**Notice of Public Hearing**

*Under IC 4-22-2-24, notice is hereby given that on September 16, 2002 at 10:00 a.m., at the Indiana Government Center-South, 402 West Washington Street, Conference Center Room B, Indianapolis, Indiana; AND on November 6, 2002 at 10:00 a.m., at the Indiana Government Center-South, 402 West Washington Street, Conference Center Room B, Indianapolis, Indiana the Fire Prevention and Building Safety Commission will hold a public hearing on proposed amendments to the Indiana Fire Code, 2003 Edition, which adopts, with Indiana Amendments, the 2000 International Fire Code. Copies of these rules are now on file at the Indiana Government Center-South, 402 West Washington Street, Room W246 and Legislative Services Agency, One North Capitol, Suite 325, Indianapolis, Indiana and are open for public inspection.*

Patrick Ralston  
Secretary  
Fire Prevention and Building Safety Commission

---

---

**TITLE 675 FIRE PREVENTION AND BUILDING SAFETY COMMISSION**

**Proposed Rule**  
LSA Document #02-118

**DIGEST**

Adds 675 IAC 25, which adopts by reference and amends the 2000 International Fuel Gas Code as the Indiana Fuel Gas Code, 2003 Edition. Effective 30 days after filing with the secretary of state.

**675 IAC 25**

SECTION 1. 675 IAC 25 IS ADDED TO READ AS FOLLOWS:

---

---

## Proposed Rules

---

---

### ARTICLE 25. FUEL GAS CODE

#### Rule 1. Indiana Fuel Gas Code, 2003 Edition

675 IAC 25-1-1 Adoption by reference; title; availability; scope; purpose

Authority: IC 22-13-2-2

Affected: IC 22-12; IC 22-13; IC 22-14; IC 22-15; IC 36-7-2-9

Sec. 1. (a) That certain document being titled the International Fuel Gas Code, fifth printing, published by the International Code Council, 5203 Leesburg Pike, Suite 708, Falls Church, Virginia 22041-3401, is hereby adopted by reference as if fully set out in this rule save and except those revisions made in this rule.

(b) This rule is available for review and reference at the Fire and Building Services Department, Indiana Government Center-South, 402 West Washington Street, Room W246, Indianapolis, Indiana 46204. (*Fire Prevention and Building Safety Commission; 675 IAC 25-1-1*)

675 IAC 25-1-2 Chapter 1; administration

Authority: IC 22-13-2-2

Affected: IC 4-21.5; IC 4-22-7-7; IC 22-12-7; IC 22-13-5; IC 22-14; IC 22-15; IC 36-7-2-9

Sec. 2. Delete Chapter 1 and substitute to read as follows:

#### Section 101 Application

##### 101.1 Title

This rule shall be known as the Indiana Fuel Gas Code, 2003 edition and shall be published, except incorporated documents, by the fire and building services department, for general distribution and use under that title. Wherever the term "this code" is used throughout this rule, it shall mean the Indiana Fuel Gas Code, 2003 edition.

##### 101.2 Scope.

This code shall apply to the installation of fuel gas piping systems, fuel gas utilization equipment, and related accessories as follows:

1. Coverage of piping systems shall extend from the point of delivery to the connections with gas utilization equipment. (See "point of delivery.")
2. Systems with an operating pressure of 125 psig (862 kPa gauge) or less.  
Piping systems for gas-air mixtures within the flammable range with an operating pressure of 10 psig (69 kPa gauge).  
LP-Gas piping systems with an operating pressure of 20 psig (140 kPa gauge) or less.
3. Piping systems requirements shall include design, materials, components, fabrication, assembly, installa-

tion, testing, inspection, operation, and maintenance.

4. Requirements for gas utilization equipment and related accessories shall include installation, combustion and ventilation air and venting.

This code shall not apply to the following:

1. Portable LP-Gas equipment of all types that are not connected to a fixed fuel piping system.
2. Installation of farm equipment such as brooders, dehydrators, dryers, and irrigation equipment.
3. Raw material (feedstock) applications except for piping to special atmosphere generators.
4. Oxygen-fuel gas cutting and welding systems.
5. Industrial gas applications using gases such as acetylene and acetylenic compounds, hydrogen, ammonia, carbon monoxide, oxygen, and nitrogen.
6. Petroleum refineries, pipeline compressor or pumping stations, loading terminals, compounding plants, refinery tank farms, and natural gas processing plants.
7. Integrated chemical plants or portions of such plants where flammable or combustible liquids or gases are produced by chemical reactions or used in chemical reactions.
8. LP-Gas installations.
9. Liquefied natural gas (LNG) installations.
10. Fuel gas piping in power and atomic energy plants.
11. Proprietary items of equipment, apparatus, or instruments such as gas generating sets, compressors, and calorimeters.
12. LP-Gas equipment for vaporization, gas mixing, and gas manufacturing.
13. Temporary LP-Gas piping for buildings under construction or renovation that is not to become part of the permanent piping system.
14. Installation of LP-Gas systems for railroad switch heating.
15. Installation of LP-Gas and compressed natural gas (CCNG) systems on vehicles.
16. Except as provided in Section 401.1.1, gas piping, meters, gas pressure regulators, and other appurtenances used by the serving gas supplier in the distribution of gas, other than undiluted LP-Gas.
17. Building design and construction, except as specified herein.

##### 101.3 Appendices and Standards

Provisions in the appendices are not enforceable unless specifically adopted.

The codes and standards referenced in this code shall be considered part of the requirements of this code to the prescribed extent of each such reference. Where differences occur between provisions of this code and referenced codes and standards, the provisions of this code shall apply.



**EXCEPTION:** Where enforcement of a code provision would violate the conditions of the listing, labeling or manufacturer's installation instructions of the equipment or appliance, the conditions of the listing, labeling or manufacturer's instructions shall apply.

#### 101.4 Appeals and Interpretations

Appeals from orders issued by the Fire Prevention and Building Safety Commission, the Office of the State Building Commissioner or the Office of the State Fire Marshal are governed by IC 4-21.5 and IC 22-12-7. Appeals from orders by a local unit of government are governed by IC 22-13-2-7 and local ordinance. Upon the written request of an interested person who has a dispute with a county or municipal government concerning a building rule, the Office of the State Building Commissioner may issue a written interpretation of a building law. The written interpretation as issued under IC 22-13-5 binds the interested person and the county or municipality with whom the interested person has the dispute until overruled under IC 4-21.5. A written interpretation of a building law binds all counties and municipalities if the office of the state building commissioner publishes the written interpretation of the building law in the Indiana Register under IC 4-22-7-7(b).

#### 101.5 Plans

Plans shall be submitted for Class 1 structures as required by the General Administrative Rules (675 IAC 12) and the Industrialized Building Systems (675 IAC 15).

#### 101.6 Existing Construction

For existing Class 1 structures, see the General Administrative Rules (675 IAC 12) and local ordinance.

#### 101.7 Additions and Alterations

Additions and alterations to any Class 1 structure shall conform to that required of a new structure without requiring the existing structure to comply with all the requirements of this code. Additions or alterations shall not cause an existing structure to become unsafe (See the General Administrative Rules (675 IAC 12-4)).

#### 101.8 Alternate Materials, Methods, and Equipment

Alternate materials, methods, equipment, and design shall be as required by the General Administrative Rules (675 IAC 12-6-11) and the rules for Industrialized Building Systems (675 IAC 15). (*Fire Prevention and Building Safety Commission; 675 IAC 25-1-2*)

#### 675 IAC 25-1-3 Chapter 2; definitions

Authority: IC 22-13-2-2

Affected: IC 22-12; IC 22-13; IC 22-14; IC 22-15; IC 25-4; IC 25-31; IC 36-7-2-9

Sec. 3. (a) Change the following definition to read as follows:

**APPROVED** as to materials, equipment, design, and types of construction, acceptance by the code official by one (1) of the following methods:

(1) investigation or tests conducted by recognized authorities; or

(2) investigation or tests conducted by technical or scientific organizations; or accepted principles.

The investigation, tests or principles shall establish that the materials, equipment and types of construction are safe for their intended purpose.

**CODE OFFICIAL.** The office of the state building commissioner is authorized under IC 22-15-2-7; the office of the state fire marshal authorized under IC 22-14-2-10; the local building official authorized under IC 36-7-9 and local ordinance; the fire department authorized under IC 36-8-17-9.

**CONSTRUCTION DOCUMENTS.** See the General Administrative Rules (675 IAC 12-6) and the rules for Industrialized Building Systems (675 IAC 15).

**LABELED.** Equipment, devices, appliances, or materials to which has been attached a label, symbol, or other identifying mark of an organization engaged in product evaluation, that maintains periodic inspection or production of labeled equipment or materials and by whose labeling the manufacturer indicates compliance with appropriate standards or performance in a specified manner.

**LISTED.** Equipment, appliances, devices, or materials included in a list published by an organization engaged in product evaluation, that maintains periodic inspection of production of listed equipment or materials and whose listing states either that the equipment or material meets appropriate standards or has been tested and found suitable for use in a specified manner.

(b) Add the following definition to read as follows:

**ICC ELECTRICAL CODE.** See the Indiana Electrical Code (675 IAC 17).

**INTERNATIONAL CODES.** See Indiana Codes (675 IAC), Rules of the Fire Prevention and Building Safety Commission.

**INTERNATIONAL BUILDING, FIRE, MECHANICAL, FUEL GAS, ENERGY CONSERVATION, PLUMBING, AND RESIDENTIAL CODES** mean the **INDIANA BUILDING, FIRE, MECHANICAL, FUEL GAS, ENERGY CONSERVATION, PLUMBING, AND RESIDENTIAL CODES.**

---

---

## Proposed Rules

---

---

**REGISTERED DESIGN PROFESSIONAL.** A registered architect or professional engineer who is registered under IC 25-4 or IC 25-31.

**If a registered design professional is not required by 675 IAC 12-6 or 675 IAC 15, then it means the owner.**

*(Fire Prevention and Building Safety Commission; 675 IAC 25-1-3)*

**675 IAC 25-1-4 Section 301.3; listed and labeled**

Authority: IC 22-13-2-2

Affected: IC 22-12; IC 22-13; IC 22-14; IC 22-15; IC 36-7-2-9

**Sec. 4. Change Section 301.3 Listed and labeled to read as follows: Appliances regulated by this code shall be listed and labeled unless otherwise approved.** *(Fire Prevention and Building Safety Commission; 675 IAC 25-1-4)*

**675 IAC 25-1-5 Sections 301.4, 301.4.1, 301.4.2, 301.4.2.1, 301.4.2.2, and 301.4.2.3; labeling, testing, inspection and identification, equipment, and personnel**

Authority: IC 22-13-2-2

Affected: IC 22-12; IC 22-13; IC 22-14; IC 22-15; IC 36-7-2-9

**Sec. 5. Delete Sections 301.4 through 301.4.2.3 without substitution.** *(Fire Prevention and Building Safety Commission; 675 IAC 25-1-5)*

**675 IAC 25-1-6 Section 305.1; general**

Authority: IC 22-13-2-2

Affected: IC 22-12; IC 22-13; IC 22-14; IC 22-15; IC 36-7-2-9

**Sec. 6. Change Section 305.1 by deleting from the last line “and the requirements determined by the code official” and inserting “or other approved methods”.** *(Fire Prevention and Building Safety Commission; 675 IAC 25-1-6)*

**675 IAC 25-1-7 Section 305.3; public garages**

Authority: IC 22-13-2-2

Affected: IC 22-12; IC 22-13; IC 22-14; IC 22-15; IC 36-7-2-9

**Sec. 7. Amend Section 305.3, in the EXCEPTION, by deleting “and NFPA 88B”.** *(Fire Prevention and Building Safety Commission; 675 IAC 25-1-7)*

**675 IAC 25-1-8 Section 412; liquified petroleum gas motor vehicle fuel-dispensing station**

Authority: IC 22-13-2-2

Affected: IC 22-12; IC 22-13; IC 22-14; IC 22-15; IC 36-7-2-9

**Sec. 8. In Section 412 Liquefied petroleum gas motor vehicle fuel-dispensing station, delete the entire text and insert “See the Indiana Fire Code (675 IAC 22)”.** *(Fire Prevention and Building Safety Commission; 675 IAC 25-1-8)*

**675 IAC 25-1-9 Section 413; compressed natural gas motor vehicle fuel-dispensing stations**

Authority: IC 22-13-2-2

Affected: IC 22-12; IC 22-13; IC 22-14; IC 22-15; IC 36-7-2-9

**Sec. 9. In Section 413 Compressed natural gas motor vehicle fuel-dispensing stations, delete the entire text and insert “See the Indiana Fire Code (675 IAC 22)”.** *(Fire Prevention and Building Safety Commission; 675 IAC 25-1-9)*

**Notice of Public Hearing**

*Under IC 4-22-2-24, notice is hereby given that on September 16, 2002 at 10:00 a.m., at the Indiana Government Center-South, 402 West Washington Street, Conference Center Room B, Indianapolis; AND on November 6, 2002 at 10:00 a.m., at the Indiana Government Center-South, 402 West Washington Street, Conference Center Room B, Indianapolis, Indiana the Fire Prevention and Building Safety Commission will hold a public hearing on proposed new rules to be known as the Indiana Fuel Gas Code, 2003 Edition. Copies of these rules are now on file at the Indiana Government Center-South, 402 West Washington Street, Room W246 and Legislative Services Agency, One North Capitol, Suite 325, Indianapolis, Indiana and are open for public inspection.*

Patrick Ralston

Secretary

Fire Prevention and Building Safety Commission

---

---

## TITLE 804 BOARD OF REGISTRATION FOR ARCHITECTS AND LANDSCAPE ARCHITECTS

### Proposed Rule

LSA Document #02-20

### DIGEST

Amends 804 IAC 1.1-3-1 to revise the fees charged and collected by the board of registration for architects and landscape architects. Effective 30 days after filing with the secretary of state.

### 804 IAC 1.1-3-1

SECTION 1. 804 IAC 1.1-3-1 IS AMENDED TO READ AS FOLLOWS:

### 804 IAC 1.1-3-1 Fees charged by board

Authority: IC 25-1-8-2; IC 25-4-1-3; IC 25-4-2

Affected: IC 25-4-1-16; IC 25-4-2-8

Sec. 1. (a) The state board of registration for architects and landscape architects shall charge and collect the following fees:

(1) For submitting an application for examination for registration as an architect or landscape architect, a fee of ~~fifteen~~ **fifty** dollars (~~\$15~~): **\$50**.

(2) For the examination or reexamination of an application for a registration to practice as an architect or landscape architect, a fee in an amount determined by the board which may not exceed the cost of the examination administration

~~therefor thereof~~ and grading thereof which is charged to the board plus twenty percent (20%) of such charge.

(3) For the processing and review of qualifications for registration as an architect or landscape architect by reciprocity ~~eighty with a NCARB or CLARB record, one hundred dollars (\$80):~~ **(\$100)**.

**(4) For the processing and review of qualifications for registration as an architect or landscape architect by reciprocity in the absence of a NCARB or CLARB record, four hundred dollars (\$400).**

~~(4)~~ **(5)** For issuance of the original certificate of registration to practice as an architect or landscape architect either following passage of the examination or approved as a reciprocal applicant:

(A) When the certificate of registration is dated between December 1 of an even-numbered year and November 30 of the following odd-numbered year, inclusive, ~~ten fifty~~ **dollars (\$10): (\$50)**.

(B) When the certificate of registration is dated between December 1 of an odd-numbered year and November 30 of the following even-numbered year, inclusive, ~~twenty one~~ **hundred dollars (\$20): (\$100)**.

~~(5)~~ **(6)** For the biennial renewal of the registration to practice as an architect or landscape architect, ~~fifteen one hundred~~ **dollars (\$15) (\$100)** payable prior to November 30 of each odd-numbered year.

~~(6)~~ **(7)** For the restoration of an expired registration to practice as an architect or landscape architect, ~~ten one~~ **hundred dollars (\$10) (\$100)** for each license year or part of a license year of delinquency, plus all unpaid renewal fees.

~~(7)~~ **(8)** For the replacement or duplicate certificate of registration to practice as an architect or landscape architect, ~~ten~~ **thirty dollars (\$10): (\$30)**.

~~(8)~~ For issuance of a temporary certificate of registration to an out-of-state landscape architect, for a period not to exceed one (1) year or for the duration of a specific project for a specific site, a fee of seventy-five dollars (\$75):

~~(9)~~ Proctoring fee is ~~fifty seventy-five~~ **dollars (\$50): (\$75)**.

(b) All fees are nonrefundable, nontransferable and all examination fees are nonapplicable in any case to succeeding examinations. (*Board of Registration for Architects and Landscape Architects; 804 IAC 1.1-3-1; filed Mar 25, 1980, 9:15 a.m.: 3 IR 954; filed Oct 19, 1981, 10:30 a.m.: 4 IR 2845; filed Jan 8, 1982, 10:10 a.m.: 5 IR 395; filed Apr 26, 1983, 9:31 a.m.: 6 IR 1082; filed Sep 22, 1983, 3:30 p.m.: 6 IR 2415; filed Nov 14, 1985, 8:39 a.m.: 9 IR 762; filed Jun 28, 1996, 9:45 a.m.: 19 IR 3085; readopted filed May 10, 2001, 2:40 p.m.: 24 IR 3235*)

#### **Notice of Public Hearing**

*Under IC 4-22-2-24, notice is hereby given that on August 14, 2002 at 10:00 a.m., at the Indiana Government Center-South, 402 West Washington Street, Conference Center Room 12,*

*Indianapolis, Indiana the State Board of Registration for Architects and Landscape Architects will hold a public hearing on proposed amendments to revise the fees charged and collected by the board of registration for architects and landscape architects. Copies of these rules are now on file at the Indiana Government Center-South, 302 West Washington Street, Room E012 and Legislative Services Agency, One North Capitol, Suite 325, Indianapolis, Indiana and are open for public inspection.*

Gerald H. Quigley  
Executive Director  
Indiana Professional Licensing Agency

---

---

## **TITLE 828 STATE BOARD OF DENTISTRY**

### **Proposed Rule**

LSA Document #02-112

### **DIGEST**

Adds 828 IAC 0.5-2-6 concerning fees related to approval of sponsors of continuing education. Amends 828 IAC 1-5-1 concerning approval of study clubs as sponsors of continuing education. Adds 828 IAC 1-5-1.5 concerning approval of study clubs as sponsors of continuing education. Amends 828 IAC 1-5-2 concerning approval of organizations or individuals as sponsors of continuing education. Adds IAC 1-5-2.5 concerning approval of organizations or individuals as sponsors of continuing education. Amends 828 IAC 1-6-1 concerning renewal requirements for dental hygienists. Effective 30 days after filing with the secretary of state.

**828 IAC 0.5-2-6**

**828 IAC 1-5-2**

**828 IAC 1-5-1**

**828 IAC 1-5-2.5**

**828 IAC 1-5-1.5**

**828 IAC 1-6-1**

SECTION 1. 828 IAC 0.5-2-6 IS ADDED TO READ AS FOLLOWS:

#### **828 IAC 0.5-2-6 Continuing education; sponsor approval fees**

**Authority:** IC 23-1.5-2-9; IC 23-1.5-2-10; IC 25-1-8-2; IC 25-13-1-5; IC 25-14-1-13

**Affected:** IC 25-13-1-8; IC 25-13-2-2; IC 25-14-1-10; IC 25-14-3-2

**Sec. 6. (a) This section applies to study clubs applying for approval under IC 25-13-2-2(12) or IC 25-14-3-2(12).**

**(b) This section applies to organizations or individuals applying for approval under IC 25-13-2-2(18) or IC 25-14-3-2(18).**

**(c) The board shall charge and collect the following fees related to the approval of study clubs, organizations, and individuals as sponsors of continuing education:**

## Proposed Rules

- (1) Study club application for approval \$ 250  
(2) Organization or individual application for approval \$ 250

(State Board of Dentistry; 828 IAC 0.5-2-6)

SECTION 2. 828 IAC 1-5-1 IS AMENDED TO READ AS FOLLOWS:

### 828 IAC 1-5-1 Application for approval of study clubs

Authority: IC 25-13-2-10; IC 25-14-3-12

Affected: IC 25-13-2; IC 25-14-3

Sec. 1. (a) Study clubs must submit a ~~written request an application and a fee~~ for approval of the study club at least thirty (30) days prior to the date of the study club's presentation of a program for as a sponsor of continuing education credit for dentists and/or dental hygienists. Programs presented:

- (1) prior to the receipt of approval; or
- (2) after the withdrawal or termination of approval of the study club;

by the board shall not count toward continuing education requirements.

(b) The ~~written request application~~ for approval shall include the following:

- (1) The name of the study club.
- (2) The address of the study club.
- (3) A statement that the study club is organized for the purpose of scientific study.
- (4) A statement that the study club operates under the direction of elected officers.
- (5) The names and addresses of each officer.
- (6) A copy of the study club's bylaws.
- (7) The names of at least five (5) members of the study club.
- (8) A statement that the study club will conduct regular meetings.
- (9) A statement that the study club will maintain written attendance records of all meetings, which shall be submitted to the board upon request.
- (10) A description of the types of programs or activities the study club intends to present.

(c) The ~~written request application~~ for approval must be signed by an officer of the study club.

(d) ~~Approval of a study club will be valid for a maximum period of two (2) years as long as the club remains in compliance with subsection (b). The study club is responsible for applying to the board for renewal of approval.~~ (State Board of Dentistry; 828 IAC 1-5-1; filed Jan 28, 1992, 5:00 p.m.: 15 IR 1015; filed Mar 26, 1993, 5:00 p.m.: 16 IR 1952; filed Sep 1, 2000, 2:20 p.m.: 24 IR 22; readopted filed Apr 11, 2001, 3:21 p.m.: 24 IR 2896)

SECTION 3. 828 IAC 1-5-1.5 IS ADDED TO READ AS FOLLOWS:

### 828 IAC 1-5-1.5 Study club sponsor approval; expiration

Authority: IC 25-13-2-10; IC 25-14-3-12

Affected: IC 25-13-2-2; IC 25-14-3-2

Sec. 1.5. (a) A study club continuing education sponsor approval issued by the board shall be valid for the remainder of the approval period in effect on the date the approval was issued.

(b) The approval issued by the board expires on March 2 of even-numbered years.

(c) The approval is not renewable. A new application and fee for study club continuing education sponsor approval must be filed for each license period.

(d) The approval of a study club sponsor issued by the board:

(1) prior to the effective date of this rule; and

(2) that is current and good standing;

shall remain valid until March 2, 2004. (State Board of Dentistry; 828 IAC 1-5-1.5)

SECTION 4. 828 IAC 1-5-2 IS AMENDED TO READ AS FOLLOWS:

### 828 IAC 1-5-2 Application for approval of organizations or individuals

Authority: IC 25-13-2-10; IC 25-14-3-12

Affected: IC 25-13-2-2; IC 25-14-3-2

Sec. 2. (a) This section applies to organizations or individuals referred to in IC 25-13-2-2(18) and IC 25-14-3-2(18).

(b) Individuals or organizations applying for approval must submit a ~~written request an application and a fee~~ for approval at least thirty (30) days prior to the date of the individual's or organization's presentation of a program for as a sponsor of continuing education credit for dentists and/or dental hygienists. Programs presented:

(1) prior to the receipt of approval; or

(2) after the withdrawal or termination of approval of the individual or organization;

by the board shall not count toward continuing education requirements.

(c) The ~~written request application~~ for approval shall include the following:

(1) The name of the sponsoring individual or organization.

(2) The address and telephone number of the individual or organization.

(3) The following for organizations:

(A) A copy of all documents relating to the formation and continued existence of the organization.

(B) A description of the specific purposes for which the organization was formed.

(C) For each individual in the organization with direct responsibility for teaching and conducting an educational program of the organization, a vita or resume listing all educational and relevant work experience.

(4) For individuals, a vita or resume listing all educational and relevant work experience.

(5) A list of each educational program presented or sponsored by the individual or organization for five (5) years prior to the date of the request for approval.

(6) The following for each program listed under subdivision (5) given in the prior two (2) years:

(A) The date and location of the program.

(B) A brief summary of the content of the program.

(C) The name and the academic and professional background of the lecturer.

(D) The number of clock hours of continuing education credit granted by a state licensing or similar regulatory authority for the program.

(7) A description of the course evaluation technique utilized for all educational programs.

(8) A sample of the certificate awarded for the completion of all educational programs, if available.

(9) A list of all anticipated programs to be presented or sponsored during the requested approval period, if available.

(10) A description of the types of programs or activities the individual or organization intends to present.

(11) A description of the method to be used for monitoring attendance.

(d) The individual or organization is responsible for monitoring attendance in such a way that verification of attendance throughout the program can be reliably assured.

~~(c) Approval of the individual or organization will be valid for a maximum period of two (2) years. The individual or organization is responsible for applying to the board for renewal of approval. (State Board of Dentistry; 828 IAC 1-5-2; filed Jan 28, 1992, 5:00 p.m.: 15 IR 1015; filed Mar 26, 1993, 5:00 p.m.: 16 IR 1953; filed Sep 1, 2000, 2:20 p.m.: 24 IR 22; readopted filed Apr 11, 2001, 3:21 p.m.: 24 IR 2896)~~

SECTION 5. 828 IAC 1-5-2.5 IS ADDED TO READ AS FOLLOWS:

**828 IAC 1-5-2.5 Individual or organization sponsor approval; expiration**

Authority: IC 25-13-2-10; IC 25-14-3-12

Affected: IC 25-13-2-2; IC 25-14-3-2

**Sec. 2.5. (a) Approval of an individual or organization as a sponsor of continuing education issued by the board shall be valid for the remainder of the approval period in effect on the date the approval was issued.**

**(b) The approval issued by the board expires on March 2 of even-numbered years.**

**(c) The approval is not renewable. A new application and fee for an individual or organization continuing education sponsor approval must be filed for each license period.**

**(d) The approval of a sponsor issued by the board:**

**(1) prior to the effective date of this rule; and**

**(2) that is current and in good standing;**

**shall remain valid until March 2, 2004.** (State Board of Dentistry; 828 IAC 1-5-2.5)

SECTION 6. 828 IAC 1-6-1 IS AMENDED TO READ AS FOLLOWS:

**828 IAC 1-6-1 Renewal requirements; basic life support certification**

Authority: IC 25-13-1-5; IC 25-13-1-8; IC 25-14-1-13

Affected: IC 25-13-2-6; IC 25-13-2-9

Sec. 1. (a) Applicants for dental hygiene license renewal must be certified in or successfully complete a course in basic life support. ~~A course in basic life support shall include lecture and hands-on use of the following:~~

~~(1) Adult one-rescuer cardiopulmonary resuscitation;~~

~~(2) Adult two-rescuer cardiopulmonary resuscitation;~~

~~(3) Child one-rescuer cardiopulmonary resuscitation;~~

~~(4) Airway obstruction and devices.~~

(b) Courses on health care provider cardiopulmonary resuscitation or cardiopulmonary resuscitation for the professional rescuer meet the requirements of this rule.

(c) At the time of renewal of the license, the applicant must submit, as a part of the renewal application, a sworn statement signed by the applicant attesting that the applicant has fulfilled the requirement to complete a course in basic life support.

**(d) A waiver of the requirement to complete a course in basic life support will only be granted for medical conditions or disabilities that prevent the dental hygienist from complying with the basic life support requirement. All requests for waivers of the basic life support requirement must be submitted in writing with the renewal application. A physician's statement documenting the disability or medical condition must be submitted with the request.**

(e) The board will conduct an audit for compliance in conjunction with the audit conducted under IC 25-13-2-9.

~~(f)~~ (f) In order to comply with IC 25-13-1-8(b)(3), a course in basic life support must be successfully completed during each two (2) year license period.

~~(g)~~ (g) If a dental hygienist is audited for compliance with the requirement for completion of a basic life support course, at the time of the audit the dental hygienist must submit ~~either:~~ **any of the following:**

---

---

## Proposed Rules

---

---

(1) A copy of the cardiopulmonary resuscitation card showing the date of issuance and the date of expiration or date it is due for renewal. ✕

(2) A copy of the attendance sheet for the course that has been signed by the instructor and includes the date the course was given and certifies that the applicant successfully completed the course.

**(3) Proof of reasonable cause for noncompliance. A waiver will only be granted for medical conditions or disabilities that prevent the dental hygienist from complying with the basic life support requirement. All requests for waivers of the basic life support requirement must be submitted in writing. A physician's statement documenting the disability or medical condition must be submitted with the request.**

*(State Board of Dentistry; 828 IAC 1-6-1; filed Aug 29, 1997, 8:45 a.m.; 21 IR 107; readopted filed Apr 11, 2001, 3:21 p.m.; 24 IR 2896)*

### Notice of Public Hearing

*Under IC 4-22-2-24, notice is hereby given that on August 2, 2002 at 10:30 a.m., at the Indiana Government Center-South, 402 West Washington Street, Conference Center Room A, Indianapolis, Indiana the State Board of Dentistry will hold a public hearing on proposed rules concerning fees related to approval of sponsors of continuing education; approval of study clubs as sponsors of continuing education; approval of organizations or individuals as sponsors of continuing education; and renewal requirements for dental hygienists. Copies of these rules are now on file at the Indiana Government Center-South, 402 West Washington Street, Room W041 and Legislative Services Agency, One North Capitol, Suite 325, Indianapolis, Indiana and are open for public inspection.*

Lisa R. Hayes  
Executive Director  
Health Professions Bureau

---

---

### TITLE 828 STATE BOARD OF DENTISTRY

#### Proposed Rule

LSA Document #02-113

#### DIGEST

Amends 828 IAC 1-3 concerning requirements for licensure by endorsement. Repeals 828 IAC 1-3-1. Effective 30 days after filing with the secretary of state.

828 IAC 1-3-1  
828 IAC 1-3-1.1  
828 IAC 1-3-1.5

828 IAC 1-3-2  
828 IAC 1-3-3

SECTION 1. 828 IAC 1-3-1.1 IS ADDED TO READ AS FOLLOWS:

### 828 IAC 1-3-1.1 Dental licensure by endorsement; credentials

Authority: IC 25-14-1-13  
Affected: IC 25-14-1-16

**Sec. 1.1. (a) Persons seeking licensure to practice dentistry by endorsement shall file an application on a form supplied by the board and submit the fees required by 828 IAC 0.5-2-3.**

**(b) The applicant for a license shall provide the following:**

**(1) Where the name on any document differs from the applicant's name, a notarized or certified copy of a marriage certificate or legal proof of name change.**

**(2) Two (2) recent passport-type photographs of the applicant, taken within eight (8) weeks prior to filing of the application.**

**(3) An original transcript of the applicant's dental hygiene education, including the degree or degrees conferred and the date each degree was conferred.**

**(4) If the applicant has been convicted of a criminal offense, excluding minor traffic violations, the applicant shall submit a notarized statement detailing all criminal offenses, excluding minor traffic violations, for which the applicant has been convicted. This notarized statement must include the following:**

**(A) The offense of which the applicant was convicted.**

**(B) The court in which the applicant was convicted.**

**(C) The cause number under which the applicant was convicted.**

**(D) The penalty imposed by the court.**

**(5) An applicant who is now, or has been, licensed to practice any health profession in another state or Canadian province must submit verification of license status. This information must be sent by the state or province that issued the license directly to the Indiana board.**

**(6) The applicant shall submit a self-query form completed by the National Practitioner Data Bank (NPDB) and the Healthcare Integrity and Protection Data Bank (HIPDB) data bank.**

**(7) The applicant shall submit proof of completion of at least twenty (20) hours of continuing dental education taken in the previous two (2) years. No more than two (2) hours of training in basic life support shall count toward this requirement.**

**(8) The applicant shall submit proof that the applicant successfully completed the National Board Dental Examination provided by the Joint Commission on Dental Examinations or successfully completed the National Dental Examining Board of Canada Written Examination provided by the National Dental Examining Board of Canada.**

(9) The applicant shall submit proof that the applicant satisfactorily completed a regional, state, or provincial clinical licensing examination in any other state or Canadian province having and maintaining a standard of examination for licensure and laws regulating the practice of dentistry within that state or province that are substantially equivalent to the examination and licensing requirements of Indiana.

(10) The applicant shall submit proof that the applicant has been engaged in the active practice of dentistry for not less than five (5) years out of the nine (9) years immediately preceding the submission of the application.

(11) The applicant shall submit written statements from at least three (3) practicing dentists verifying the applicant's active, moral, and ethical practice of dentistry. The statements must be originals and must have been written not more than eight (8) weeks prior to the submission of the application.

(12) The applicant shall submit proof that the applicant is currently certified in basic life support or advanced cardiac life support.

(13) All information on the application shall be submitted under oath or affirmation, subject to the penalties for perjury.

(c) An applicant who has previously failed an examination for licensure administered by the board is not eligible to apply for a license by endorsement, until such applicant has passed all portions of the examination in which he or she failed or provides the board with proof that additional training has been received in the subjects of the failure. *(State Board of Dentistry; 828 IAC 1-3-1.1)*

SECTION 2. 828 IAC 1-3-1.5 IS ADDED TO READ AS FOLLOWS:

**828 IAC 1-3-1.5 Licensure to practice dental hygiene by endorsement; credentials**

Authority: IC 25-13-1-5; IC 25-14-1-13  
Affected: IC 25-13-1-7; IC 25-13-1-17

Sec. 1.5. (a) Persons seeking licensure to practice dental hygiene by endorsement shall file an application on a form supplied by the board and submit the fees required by 828 IAC 0.5-2-4.

(b) The applicant for a license shall provide the following:

(1) Where the name on any document differs from the applicant's name, a notarized or certified copy of a marriage certificate or legal proof of name change.

(2) Two (2) recent passport-type photographs of the applicant, taken within eight (8) weeks prior to filing of the application.

(3) An original transcript of the applicant's dental hygiene education, including the degree or degrees conferred and the date each degree was conferred.

(4) If the applicant has been convicted of a criminal offense, excluding minor traffic violations, the applicant shall submit a notarized statement detailing all criminal offenses, excluding minor traffic violations, for which the applicant has been convicted. This notarized statement must include the following:

(A) The offense of which the applicant was convicted.

(B) The court in which the applicant was convicted.

(C) The cause number under which the applicant was convicted.

(D) The penalty imposed by the court.

(5) An applicant who is now, or has been, licensed to practice any health profession in another state must submit verification of license status. This information must be sent by the state that issued the license directly to the Indiana board.

(6) The applicant shall submit a self-query form completed by the National Practitioner Data Bank (NPDB) and the Healthcare Integrity and Protection Data Bank (HIPDB) data bank.

(7) The applicant shall submit proof of completion of at least fourteen (14) hours of continuing dental hygiene education taken within the previous two (2) years. No more than two (2) hours of training in basic life support shall count toward this requirement.

(8) All information on the application shall be submitted under oath or affirmation, subject to the penalties for perjury.

(9) The applicant shall submit proof that the applicant satisfactorily completed the National Board Dental Hygiene Examination provided by the Joint Commission on Dental Examinations.

(10) The applicant shall submit proof that the applicant satisfactorily completed a regional or state clinical licensing examination in any other state having and maintaining a standard of examination for licensure and laws regulating the practice of dental hygiene within that state or province that are substantially equivalent to the examination and licensing requirements of Indiana.

(11) The applicant shall submit proof that the applicant has been engaged in the active practice of dental hygiene for not less than two (2) years out of the five (5) years immediately preceding the submission of the application.

(12) The applicant shall submit written statements from at least three (3) practicing dentists verifying the applicant's active, moral, and ethical practice of dental hygiene. The statements must be originals and must have been written not more than eight (8) weeks prior to the submission of the application.

(13) The applicant shall submit proof that the applicant is currently certified in basic life support.

(c) An applicant who has previously failed an examination for licensure administered by the board is not eligible to apply for a license by endorsement, until such applicant

---

---

## Proposed Rules

---

---

has passed all portions of the examination in which he or she failed or provides the board with proof that additional training has been received in the subjects of the failure. (State Board of Dentistry; 828 IAC 1-3-1.5)

SECTION 3. 828 IAC 1-3-2 IS AMENDED TO READ AS FOLLOWS:

### 828 IAC 1-3-2 "Practice of dentistry" defined

Authority: IC 25-14-1-13  
Affected: IC 25-14-1-16

Sec. 2. (a) Under IC 25-14-1-16(b)(2), an applicant for licensure by endorsement must have practiced dentistry for at least five (5) out of the nine (9) years preceding the date of application.

(b) "Practice of dentistry" means that the applicant has actively engaged in clinical patient contact for at least an average of twenty (20) hours per week for five (5) years. A maximum of two (2) years of the five (5) year requirement may have been in postdoctoral training in a program approved by the board. (State Board of Dentistry; 828 IAC 1-3-2; filed Apr 19, 1991, 3:00 p.m.: 14 IR 1728; readopted filed Apr 11, 2001, 3:21 p.m.: 24 IR 2896)

SECTION 4. 828 IAC 1-3-3 IS AMENDED TO READ AS FOLLOWS:

### 828 IAC 1-3-3 "Satisfactory practice of dental hygiene" defined

Authority: IC 25-13-1-5  
Affected: IC 25-13-1-17

Sec. 3. (a) An applicant for a dental hygiene license under IC 25-13-1-17(a) must have engaged in the satisfactory practice of dental hygiene for at least ~~five (5)~~ **two (2)** years out of the preceding ~~seven (7)~~ **five (5)** years.

(b) As used in this section, "satisfactory practice of dental hygiene" means that the applicant has actively engaged in practicing dental hygiene for at least an average of twenty (20) hours per week for ~~five (5)~~ **two (2)** years. A maximum of ~~two (2)~~ **one (1)** year of the ~~five (5)~~ **two (2)** year requirement may have been in post associate degree training in dental hygiene in a program approved by the board. (State Board of Dentistry; 828 IAC 1-3-3; filed Apr 19, 1991, 3:00 p.m.: 14 IR 1728; filed Feb 4, 1994, 5:00 p.m.: 17 IR 1094; readopted filed Apr 11, 2001, 3:21 p.m.: 24 IR 2896)

SECTION 5. 828 IAC 1-3-1 IS REPEALED.

### Notice of Public Hearing

Under IC 4-22-2-24, notice is hereby given that on August 2, 2002 at 10:45 a.m., at the Indiana Government Center-South, 402 West Washington Street, Conference Center Room A,

Indianapolis, Indiana the State Board of Dentistry will hold a public hearing on proposed amendments concerning requirements for licensure by endorsement. Copies of these rules are now on file at the Indiana Government Center-South, 402 West Washington Street, Room W041 and Legislative Services Agency, One North Capitol, Suite 325, Indianapolis, Indiana and are open for public inspection.

Lisa R. Hayes  
Executive Director  
Health Professions Bureau

---

---

## TITLE 828 STATE BOARD OF DENTISTRY

### Proposed Rule

LSA Document #02-114

### DIGEST

Amends 828 IAC 0.5-2-3 and 828 IAC 0.5-2-4 concerning fees related to licensure to practice dentistry or dental hygiene. Amends 828 IAC 1-7-1 concerning inactive status for licenses to practice dentistry. Adds 828 IAC 1-7-2 concerning inactive status for licenses to practice dental hygiene. Effective 30 days after filing with the secretary of state.

**828 IAC 0.5-2-3**

**828 IAC 1-7-1**

**828 IAC 0.5-2-4**

**828 IAC 1-7-2**

SECTION 1. 828 IAC 0.5-2-3, AS ADDED AT 25 IR 1180, SECTION 1, IS AMENDED TO READ AS FOLLOWS:

### 828 IAC 0.5-2-3 Dental fees

Authority: IC 23-1.5-2-9; IC 23-1.5-2-10; IC 25-1-8-2; IC 25-13-1-5; IC 25-14-1-13  
Affected: IC 25-13-1-8; IC 25-14-1-10

Sec. 3. The board shall charge and collect the following fees related to the practice of dentistry:

- |   |  |
|---|--|
| (1) Examination administration                        | \$250 plus the cost of supplies, models, and the use of the examination facility |
| (2) Reexamination administration                      | \$150 plus the cost of supplies, models, and the use of the examination facility |
| (3) Licensure by endorsement                          | \$250  |
| (4) License renewal                                   | \$100 biennially   |
| (5) Dental intern permit application                  | \$100  |
| (6) Dental intern permit renewal                      | \$ 50  |
| (7) Verification of dental licensure to another state | \$ 10  |



## Proposed Rules

- (8) Duplicate wall license \$ 10
- (9) Professional corporation registration application \$ 25
- (10) Professional corporation registration renewal \$ 20 biennially
- (11) Application fees for the following permits: \$ 50
- (A) General anesthesia-deep sedation
- (B) Light parenteral conscious sedation
- (12) Renewal fees for the following permits: \$ 50 biennially
- (A) General anesthesia-deep sedation
- (B) Light parenteral conscious sedation
- (13) Registration of an additional office in which to administer general anesthesia, deep sedation, or light parenteral conscious sedation \$ 25
- (14) Reinstatement of inactive license \$250**

(State Board of Dentistry; 828 IAC 0.5-2-3; filed Dec 2, 2001, 12:35 p.m.: 25 IR 1180)

SECTION 2. 828 IAC 0.5-2-4, AS ADDED AT 25 IR 1181, SECTION 2, IS AMENDED TO READ AS FOLLOWS:

### 828 IAC 0.5-2-4 Dental hygiene fees

**Authority:** IC 23-1.5-2-9; IC 23-1.5-2-10; IC 25-1-8-2; IC 25-13-1-5; IC 25-14-1-13

**Affected:** IC 25-13-1-8; IC 25-14-1-10

Sec. 4. The board shall charge and collect the following fees related to the practice of dental hygiene:

- (1) Examination and/or reexamination \$100 plus the cost of supplies and the use of the examination facility
- (2) Law examination only \$ 25
- (3) Licensure by endorsement \$100
- (4) License renewal \$ 50 biennially
- (5) Dental hygiene intern permit application \$ 50
- (6) Dental hygiene intern permit renewal \$ 25
- (7) Verification of dental hygiene licensure to another state \$ 10
- (8) Duplicate wall license \$ 10
- (9) Reinstatement of inactive license \$100**

(State Board of Dentistry; 828 IAC 0.5-2-4; filed Dec 2, 2001, 12:35 p.m.: 25 IR 1181)

SECTION 3. 828 IAC 1-7-1 IS AMENDED TO READ AS FOLLOWS:

### 828 IAC 1-7-1 Inactive status for dentists

**Authority:** IC 25-14-1-10; IC 25-14-1-13

**Affected:** IC 25-14-1-27.1; IC 25-14-3-8

Sec. 1. (a) The board may issue a license to the holder of an inactive license under IC 25-14-1-27.1 if the applicant:

**(1) applies in the form and manner required by the board;**

**(1) (2) pays the renewal fee and reinstatement fee established in ~~828 IAC 0.5-2-1(3)~~; 828 IAC 0.5-2-3; and**

**(2) (3) meets the continuing education requirements established under this section.**

(b) The applicant must complete fifty percent (50%) of the continuing education that would have been required for renewal under IC 25-14-3-8 during each license period or partial license period the license was inactive.

(c) Not more than twenty-five percent (25%) of the continuing education required under this section may be in the area of practice management.

(d) The continuing education submitted must include a certification program in basic life support. Not more than two (2) credit hours for certification programs in basic life support may be applied toward the credit hour requirement. The board may waive the basic life support requirement for applicants who show reasonable cause.

(e) Documentation verifying the completion of the continuing education must be submitted to the board prior to the reactivation of the applicant's license.

(f) If the applicant's license has been inactive for five (5) or more years, the applicant shall make a personal appearance before the board. (State Board of Dentistry; 828 IAC 1-7-1; filed Sep 11, 2000, 2:20 p.m.: 24 IR 376; readopted filed Apr 11, 2001, 3:21 p.m.: 24 IR 2896)

SECTION 4. 828 IAC 1-7-2 IS ADDED TO READ AS FOLLOWS:

### 828 IAC 1-7-2 Inactive status for dental hygienists

**Authority:** IC 25-13-1-5; IC 25-14-1-13

**Affected:** IC 25-13-1-17.2; IC 25-13-2-6

**Sec. 2. (a) The board may issue a license to the holder of an inactive license under IC 25-13-1-17.2 if the applicant:**

**(1) applies in the form and manner required by the board;**

**(2) pays the renewal fee and reinstatement fee established in 828 IAC 0.5-2-4; and**

**(3) meets the continuing education requirements established under this section.**

---

---

## Proposed Rules

---

---

(b) The applicant must complete fifty percent (50%) of the continuing education that would have been required for renewal under IC 25-13-2-6 during each license period or partial license period the license was inactive.

(c) Not more than twenty-five percent (25%) of the continuing education required under this section may be in the area of practice management.

(d) The continuing education submitted must include a certification program in basic life support. Not more than two (2) credit hours for certification programs in basic life support may be applied toward the credit hour requirement. The board may waive the basic life support requirement for applicants who show reasonable cause.

(e) Documentation verifying the completion of the continuing education must be submitted to the board prior to the reactivation of the applicant's license.

(f) If the applicant's license has been inactive for five (5) or more years, the applicant shall make a personal appearance before the board. (*State Board of Dentistry; 828 IAC 1-7-2*)

### *Notice of Public Hearing*

*Under IC 4-22-2-24, notice is hereby given that on August 2, 2002 at 11:00 a.m., at the Indiana Government Center-South, 402 West Washington Street, Conference Center Room A, Indianapolis, Indiana the State Board of Dentistry will hold a public hearing on proposed amendments concerning fees related to licensure to practice dentistry or dental hygiene; inactive status for licenses to practice dentistry; and inactive status for licenses to practice dental hygiene. Copies of these rules are now on file at the Indiana Government Center-South, 402 West Washington Street, Room W041 and Legislative Services Agency, One North Capitol, Suite 325, Indianapolis, Indiana and are open for public inspection.*

Lisa R. Hayes  
Executive Director  
Health Professions Bureau

---

---

## TITLE 844 MEDICAL LICENSING BOARD OF INDIANA

**Proposed Rule**  
LSA Document #01-431

### DIGEST

Amends 844 IAC 6-1-4 concerning accreditation of educational programs. Effective 30 days after filing with the secretary of state.

### 844 IAC 6-1-4

SECTION 1. 844 IAC 6-1-4 IS AMENDED TO READ AS FOLLOWS:

### 844 IAC 6-1-4 Accreditation of educational programs

Authority: IC 25-27-1-5

Affected: IC 4-22-2-21; IC 25-27-1-1

Sec. 4. (a) The committee shall maintain a list of physical therapy and physical therapists' assistant educational programs which the committee has approved. This list shall be available in written form from the Health Professions Bureau, 402 West Washington Street, Room 041, W041, Indianapolis, Indiana 46204.

(b) An approved program is one maintaining standards equivalent to those adopted by the ~~American Physical Therapy Association, Department of Education, Standards for Accreditation of Education Programs for Physical Therapists, 1978, as published.~~ **Commission on Accreditation in Physical Therapy Education (CAPTE), Accreditation Handbook, August 2000 edition.** These standards are hereby adopted as those of the committee and are hereby incorporated by reference under IC 4-22-2-21 and ~~does do~~ not include any amendments or subsequent editions. A copy of such standards shall be available for public inspection at the office of the Health Professions Bureau, 402 West Washington Street, Room 041, W041, Indianapolis, Indiana 46204. Copies of such standards are available from the American Physical Therapy Association, 1111 North Fairfax Street, Alexandria, Virginia 22314 **or at <http://www.apta.org/Education/accreditation>.**

(c) An educational program, or a graduate or candidate for graduation from an educational program, which is not on the list of approved programs maintained by the committee, may apply to the committee for approval by petition demonstrating that the educational program meets the committee's standards for approval.

(d) The committee may remove an educational program from its list of approved programs upon the grounds that the educational program no longer meets its standards for approval. (*Medical Licensing Board of Indiana; 844 IAC 6-1-4; filed Aug 6, 1987, 3:00 p.m.: 10 IR 2732; filed Sep 22, 1994, 4:30 p.m.: 18 IR 263*)

### *Notice of Public Hearing*

*Under IC 4-22-2-24, notice is hereby given that on July 25, 2002 at 9:45 a.m., at the Indiana Government Center-South, 402 West Washington Street, Conference Center Room A, Indianapolis, Indiana the Medical Licensing Board of Indiana will hold a public hearing on proposed rules concerning accreditation of educational programs. Copies of these rules*

*are now on file at the Indiana Government Center-South, 402 West Washington Street, Room W041 and Legislative Services Agency, One North Capitol, Suite 325, Indianapolis, Indiana and are open for public inspection.*

Lisa R. Hayes  
Executive Director  
Health Professions Bureau

---

---

**TITLE 844 MEDICAL LICENSING BOARD OF INDIANA**

**Proposed Rule**  
LSA Document #01-432  
**DIGEST**

Amends 844 IAC 6-3-5 concerning temporary permits. Effective 30 days after filing with the secretary of state.

**844 IAC 6-3-5**

SECTION 1. 844 IAC 6-3-5, AS READOPTED AT 25 IR 1325, SECTION 1, IS AMENDED TO READ AS FOLLOWS:

**844 IAC 6-3-5 Temporary permits**

**Authority:** IC 25-27-1-5  
**Affected:** IC 25-27-1-6

Sec. 5. (a) For applicants for licensure by endorsement, the committee may issue a temporary, nonrenewable permit to an applicant for a license as a physical therapist or a certificate as a physical therapist's assistant where the applicant meets the requirements of section 1 of this rule, except where:

- (1) the applicant has graduated from an educational program in another state, country, or territory, not accredited by the committee; or
- (2) the applicant has not successfully completed the test required by section 2(a)(4) of this rule.

(b) For recent graduates, the committee may issue a temporary, nonrenewable permit to an applicant for a license as a physical therapist or a certificate as a physical therapist's assistant who is a graduate of **an approved** physical therapy program or **an approved** physical therapist's assistant program ~~which~~ **that** meets the standards set by the committee and who has applied for and been approved by the committee to take the examination for which the applicant has applied for licensure or certification.

(c) A candidate for a license as a physical therapist or for a certificate as a physical therapist's assistant holding a temporary permit hereunder shall only work under the direct supervision of a licensed physical therapist or physician, and shall report to the committee on a form provided by the committee, the name of the facility and supervising physical therapists or physicians.

**(d) A temporary permit shall expire on the earliest date that any one (1) of the following events occurs:**

- (1) The applicant is licensed or certified.**
- (2) The application for licensure or certification is disapproved.**
- (3) Ninety (90) days has passed since the issuance of the temporary permit.**

*(Medical Licensing Board of Indiana; 844 IAC 6-3-5; filed Aug 6, 1987, 3:00 p.m.: 10 IR 2734; filed Sep 22, 1994, 4:30 p.m.: 18 IR 265; readopted filed Nov 9, 2001, 3:16 p.m.: 25 IR 1325)*

**Notice of Public Hearing**

*Under IC 4-22-2-24, notice is hereby given that on July 25, 2002 at 9:50 a.m., at the Indiana Government Center-South, 402 West Washington Street, Conference Center Room A, Indianapolis, Indiana the Medical Licensing Board of Indiana will hold a public hearing on proposed rules concerning temporary permits. Copies of these rules are now on file at the Indiana Government Center-South, 402 West Washington Street, Room W041 and Legislative Services Agency, One North Capitol, Suite 325, Indianapolis, Indiana and are open for public inspection.*

Lisa R. Hayes  
Executive Director  
Health Professions Bureau

---

---

**TITLE 845 BOARD OF PODIATRIC MEDICINE**

**Proposed Rule**  
LSA Document #01-363

**DIGEST**

Adds 845 IAC 1-5-2.1 concerning reporting of continuing education credit. Repeals 845 IAC 1-5-2. Effective 30 days after filing with the secretary of state.

**845 IAC 1-5-2**

**845 IAC 1-5-2.1**

SECTION 1. 845 IAC 1-5-2.1 IS ADDED TO READ AS FOLLOWS:

**845 IAC 1-5-2.1 Reporting continuing education credit; audit**

**Authority:** IC 25-29-2-11; IC 25-1-4-3  
**Affected:** IC 25-29-6-4

**Sec. 2.1. (a) The licensee shall provide the board with a sworn statement signed by the licensee that the licensee has fulfilled the continuing education requirements required by the board.**

**(b) The licensee shall retain copies of certificates of**

---

---

## Proposed Rules

---

---

completion for continuing education courses for three (3) years from the end of the licensing period for which the continuing education applied. The licensee shall provide the board with copies of the certificates of completion upon the board's request for a compliance audit.

(c) Every two (2) years the board shall randomly audit for compliance more than one percent (1%) but less than ten percent (10%) of the licensees required to take continuing education courses. (Board of Podiatric Medicine; 845 IAC 1-5-2.1)

SECTION 2. 845 IAC 1-5-2 IS REPEALED.

### Notice of Public Hearing

*Under IC 4-22-2-24, notice is hereby given that on October 18, 2002 at 9:30 a.m., at the Indiana Government Center-South, 402 West Washington Street, Conference Center Room 9, Indianapolis, Indiana the Board of Podiatric Medicine will hold a public hearing on a proposed new rule concerning reporting of continuing education credit. Copies of these rules are now on file at the Indiana Government Center-South, 402 West Washington Street, Room W041 and Legislative Services Agency, One North Capitol, Suite 325, Indianapolis, Indiana and are open for public inspection.*

Lisa R. Hayes  
Executive Director  
Health Professions Bureau

---

---

## TITLE 865 STATE BOARD OF REGISTRATION FOR LAND SURVEYORS

### Proposed Rule LSA Document #02-56 DIGEST

Amends 865 IAC 1-4-8 to change the number of examination attempts for certification as a land surveyor-in-training. Amends 865 IAC 1-12-28 to modify the requirements for a surveyor location report. Effective 30 days after filing with the secretary of state.

### 865 IAC 1-4-8 865 IAC 1-12-28

SECTION 1. 865 IAC 1-4-8 IS AMENDED TO READ AS FOLLOWS:

### 865 IAC 1-4-8 Examination attempts for certification as a land surveyor-in-training

Authority: IC 25-21.5-2-14  
Affected: IC 25-21.5

Sec. 8. (a) This section applies to the examination for certification as a land surveyor-in-training.

(b) An applicant who does not pass the examination may take it ~~one (1)~~ two (2) additional time times provided that the applicant applies for the second examination within two (2) years of the date of the first examination. (*State Board of Registration for Land Surveyors; 865 IAC 1-4-8; filed Jun 21, 1988, 4:00 p.m.: 11 IR 3907; filed Oct 13, 1992, 5:00 p.m.: 16 IR 878; readopted filed May 22, 2001, 9:55 a.m.: 24 IR 3237*)  
NOTE: 864 IAC 1.1-4.1-9 was renumbered by Legislative Services Agency as 865 IAC 1-4-8.

SECTION 2. 865 IAC 1-12-28 IS AMENDED TO READ AS FOLLOWS:

### 865 IAC 1-12-28 Surveyor location reports; requirements

Authority: IC 25-31-1-7  
Affected: IC 25-31-1

Sec. 28. When conducting a surveyor location report, a registered land surveyor shall do the following:

(1) Briefly describe and show the location of any monuments found and visible evidence of possession, including, but not limited to, the following:

- (A) Buildings.
- (B) Fences.
- (C) Hedgerows.
- (D) Other improvements appurtenant to either the surveyed property or the adjoining property.

Show the location of this evidence by the shortest dimension to the nearest adjacent boundary line or any depicted easement line in order to reveal the extent of any possible encroachment. The statement "No visible evidence of possession found" must be noted along record boundary lines when applicable. (For this purpose, monuments found do not constitute evidence of possession.)

(2) Show the location, dimensions, and a brief description of all buildings or structures on the property including, but not limited to, the following:

- (A) Driveways.
- (B) Parking lots.
- (C) Such personal property as aboveground swimming pools or yard barns.

Show the location of such buildings adjacent to the boundary lines by the shortest distance thereto and dimension any violation of a depicted easement or building setback line. Identify any buildings that appear to have no foundation and may be readily moveable. Show the name of the occupant, if easily available, and any client identification data requested.

(3) Show the location of and briefly describe any visible evidence of use by others such as for roadways, utility lines, or driveways or possible joint use of driveways (do not label as "joint" or "common"), which may affect the surveyed tract. Note the name of the user, if marked (for example, joint use

by electric, telephone, and cable television companies on poles marked with electric company tags). With respect to any railroad on or adjoining the property, note if the tracks have been removed. If that is the case, note any visible evidence of construction, trenching, or other use observed on or along said railroad.

(4) Show the location and recording data for any easements or setback lines on the tract as determined from recorded documents provided by the client or from a recorded plat.

(5) Show the location of the perimeter of any visible evidence of cemeteries found on the surveyed tract.

(6) Show the approximate size, location, and brief description of any lakes, ditches, streams on the tract, or any known legal drains on or within seventy-five (75) feet of the property. Detailed locations are required when a boundary is determined thereby or when buildings or other improvements are located within a legal drain easement.

(7) Show the location of any road, street, alley, or other public way abutting or on the surveyed property with the width of the travelled way, known right-of-way lines, name, location, and source of any known name or right-of-way information indicated. If not known, note which records, if any, were searched. Physical access to the property, or lack thereof, must be shown.

(8) Show the drawing scale, a north arrow, property description and address, surveyor's job number, company name, certificate, signature, and seal, client name, and the names of those to whom the report is certified.

(9) Show a report/certificate date less than thirty (30) days from the date of delivery.

*(State Board of Registration for Land Surveyors; 865 IAC 1-12-28; filed Jul 17, 1991, 4:30 p.m.: 14 IR 2253; readopted filed May 22, 2001, 9:55 a.m.: 24 IR 3237) NOTE: 864 IAC 1.1-13-43 was renumbered by Legislative Services Agency as 865 IAC 1-12-28.*

***Notice of Public Hearing***

*Under IC 4-22-2-24, notice is hereby given that on August 9, 2002 at 9:00 a.m., at the Indiana Government Center-South, 402 West Washington Street, Conference Center Room 12, Indianapolis, Indiana the State Board of Registration for Land Surveyors will hold a public hearing on proposed amendments to change the number of examination attempts for certification as a land surveyor-in-training and to modify the requirements for a surveyor location report. Copies of these rules are now on file at the Indiana Government Center-South, 302 West Washington Street, Room E012 and Legislative Services Agency, One North Capitol, Suite 325, Indianapolis, Indiana and are open for public inspection.*

Gerald H. Quigley  
Executive Director  
Indiana Professional Licensing Agency

---

---